

SEZ. A - A

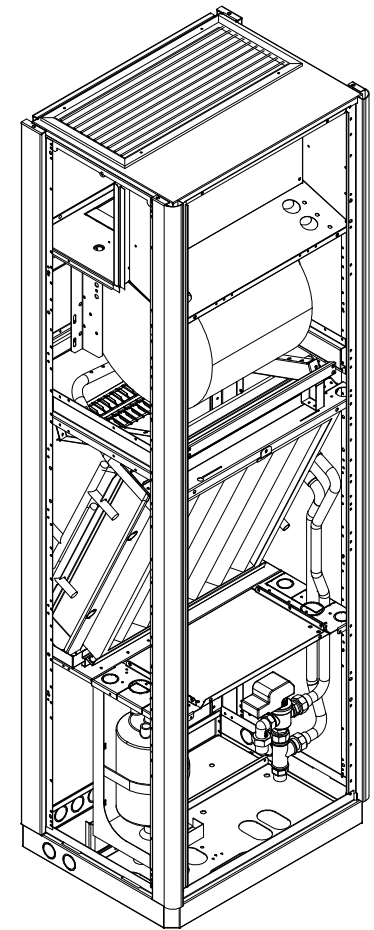
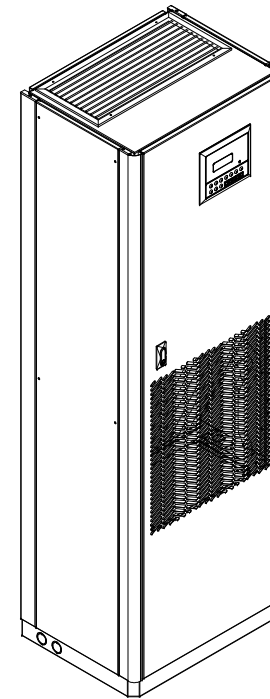
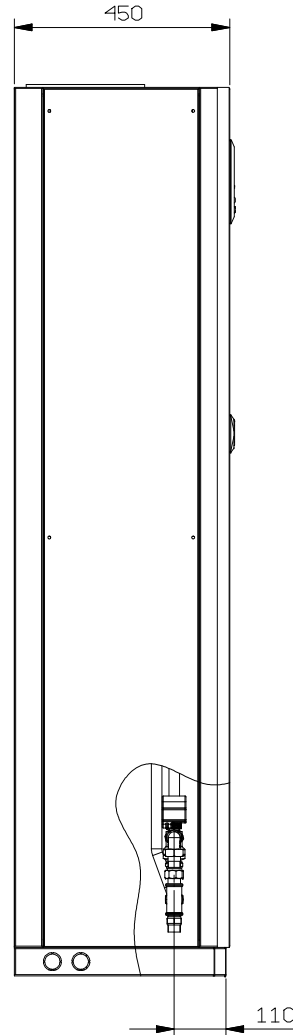
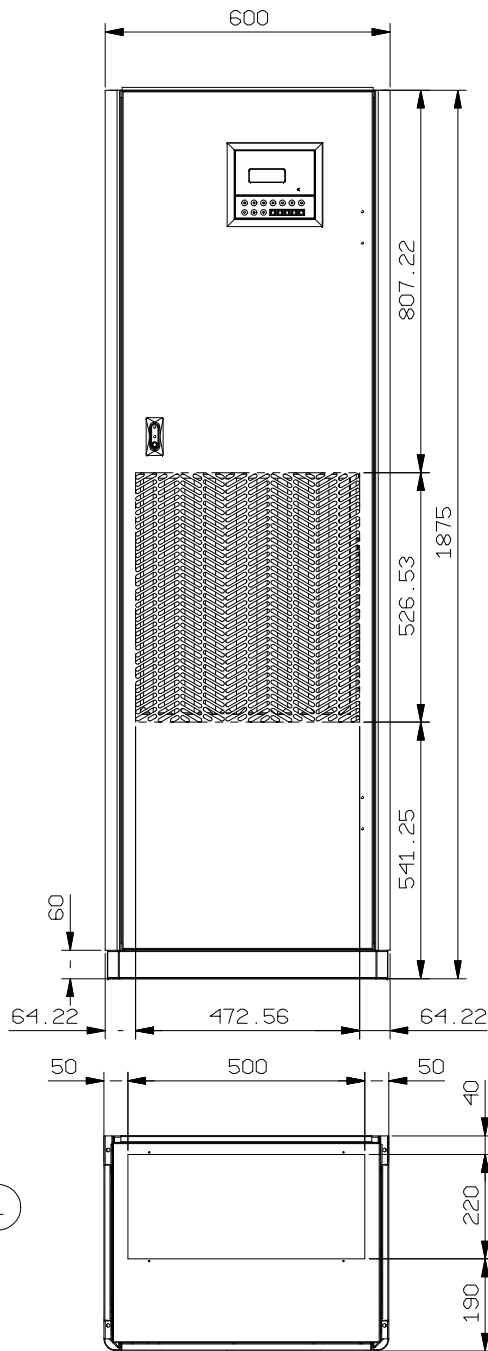
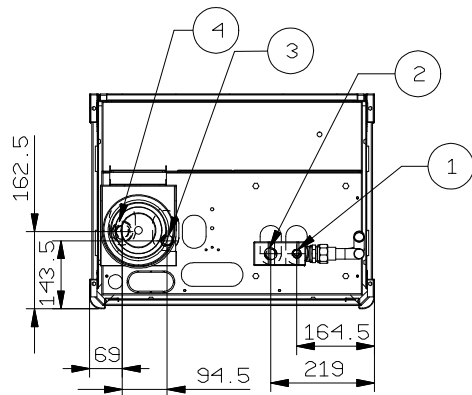

| | |
|-------|---|
| (1) | COOLING WATER INLET 3/4" GAS MALE |
| (2) | COOLING WATER OUTLET 3/4" GAS MALE |
| (3) | HUMIDIFIER WATER SUPPLY - 3/4" GAS MALE |
| (4) | HUMIDIFIER WATER DRAIN - Ø32mm |

| | | | |
|--|-------------------------|---|--------------------------------|
| LENNOX | Rev. B | Modifica - Description Aggiornate connessioni umidificatore | Date/e-Viso/Ckd 30/05/08 NP |
| | Rev. A | Modifica - Description Sostituzione valvola CW e umidificatore | Date/e-Viso/Ckd 06/03/08 NP |
| Drafterman Strazzacappa | Date - Date 04/02/05 | Scale - Scale 1:8 | |
| Descrizione - Description DIMENSIONI INGOMBRO OVERALL DIMENSIONS | | Serie - Series DH-CUC | Materiale - Material |
| Codice/Disegno - Code/Drawing HF640CC0167 | | Modello - Model 0080-0110 F_1 | Treatment - Treatment |
| Peso - Weight (kg) | | Rev. B | Viso - Checked |