

User manual

INNOV@

PCO MICROPROCESSOR



- Providing indoor climate comfort



Index

1	GENERAL DESCRIPTION OF THE APPLICATION	3
1.1	Program main functions.....	3
1.2	LCD user interface	3
1.3	LAN network connections.....	3
2	REGULATION LOGIC	4
2.1	Temperature control	4
2.1.1	Close control units with direct expansion coil.....	4
2.1.2	Other temperature functions.....	5
2.1.3	Close control units with two water coils.....	5
2.1.4	Close control units with single water coil.....	6
2.2	Humidity control	6
2.2.1	Close control units with direct expansion coil.....	7
2.2.2	Other humidity functions.....	7
2.2.3	Close control units with water coils.....	8
2.3	Recovery coil	8
2.3.1	Recovery without cooling devices.....	9
2.3.2	Recovery with cooling devices on close contr. units with direct expan. coil.....	9
2.3.3	Recovery with cooling devices on close control units with water coils	10
2.4	Outlet limit.....	11
2.5	Condenser fans.....	12
2.5.1	Single or separate coils.....	12
2.5.2	Condensing pressure probes	12
2.5.3	Prevent function.....	13
2.5.4	Speed-up function.....	13
2.5.5	Pressure – temperature conversion.....	13
2.6	Temperature set point compensation.....	13
2.7	Compressors.....	14
2.7.1	Rotation	14
2.7.2	Timing.....	14
2.7.3	Compressor alarms.....	14
2.8	Heaters	15
2.8.1	Heater alarms	15
2.9	Modulating valves	15
2.9.1	Three-position valves	15
2.9.2	0-10Volt VALVES.....	16
2.10	Outlet fan	16
3	THE USER INTERFACE	17
3.1	Keyboard description.....	17
3.1.1	Switch ON/OFF of the unit.....	17
3.1.2	Screen loop.....	17
3.2	Remote user interface	18
3.2.1	Without local display	18
3.2.2	With local display	18
4	BOARD CONFIGURATION AND CONNECTION	19
4.1	Address configuration.....	19

4.1.1	Address configuration of the microprocessor (pCO1).....	19
4.1.2	Address configuration of the PGD	19
4.1.3	Address configuration of the E2V electronic expansion valve's driver (EVD)	19
4.2	Boards connection	20
4.2.1	Stand alone unit	20
4.2.2	Units connected in LAN (max. 8 units).....	20
4.2.3	LAN status	21
4.3	Software update	21
4.3.1	Program download from hardware key	21
4.3.2	Program download from computer.....	22
4.3.3	Restore the default parameters	22
4.3.4	Language selection	23
5	ALARMS	23
5.1	Table of alarms	23
5.2	Alarm data logging	24
5.3	Main log	24
6	SCREENS	26
6.1	List of the screens	26
7	LIST OF PARAMETERS AND DEFAULT VALUES.....	28
8	ARCHITECTURE OF THE CONTROL SYSTEM	34
8.1	Microprocessor layout	34
8.2	Configuration list	35
8.3	Accessories	35
8.3.1	Electronic expansion valve.....	35
8.3.2	Accessories	36
8.3.3	Built-in humidifier	37
9	SUPERVISION	37
9.1	Supervisor and bms	37
9.2	Gsm protocol.....	39
9.3	Examples of installation.....	40
9.4	Shared external display	40
9.5	Automatic start and stand-by units.....	41
9.5.1	Critical situations.....	41
9.5.2	Forcing	41
9.5.3	Fixed-hour rotation	42
9.5.4	Fixed-day rotation	42
9.5.5	Rotation based on working hours	42
9.6	Master control	42
9.7	Technical data.....	43

1 GENERAL DESCRIPTION OF THE APPLICATION

This program manages “DX” direct expansion or “CW” water coil air-conditioning units and the main features of the application program are described below.

1.1 Program main functions

The program main functions are:

- control of temperature and humidity inside civil or technological environments
- management of 1 to 2 hermetic compressors
- management of 1 to 2 heaters (binary logic available)
- 0-10Volt and three-position modulating heating valves
- 0-10Volt and three-position modulating cooling valves
- built-in humidifier with immersed electrodes
- on-off or modulated condensing fans, pressure-controlled
- outlet temperature control
- alarms management, alarm data logging, devices timing, warnings
- complete management of devices timing
- connection with local and BMS supervisory networks (Carel, Modbus, LonWorks, ...)

1.2 LCD user interface

The LCD user interface displays the following data:

- measurement of connected probes and calibration, if required
- unit start and stop
- alarms detection
- programming of configuration and operative parameters with access protected by password
- controlled devices working hours and time bands with access protected by password
- programming of clock and time bands with access protected by password
- language selection among the available options (English, Italian, German, French)

1.3 LAN network connections

The connection with LAN network allows the program to manage the following functions as well:

- automatic time or event rotation among up to 8 units
- control of temperature and humidity of max. 8 units, taking the probes of unit no. 1 as a reference
- use of only one LCD display for controlling up to 8 units

2 REGULATION LOGIC

2.1 Temperature control

The heating and cooling devices are managed based on the temperature value measured by the ambient (or room temperature) probe. The measured temperature is compared to the set temperature (set point); the devices are enabled based on the difference between the two values. The proportional band identifies the air-conditioning unit working range and can take different values in heating and cooling mode. The dead zone identifies the devices non-action zone round the set point. The following diagrams show the action of the heating and cooling devices. The percentage values indicate the modulating valves opening range. The warm and cold valves start and end opening parameters correspond to 0% and 100% respectively (default values) and are different for the two valves; if need be, the values may be modified to delay opening start and bring complete opening forward.

2.1.1 Close control units with direct expansion coil

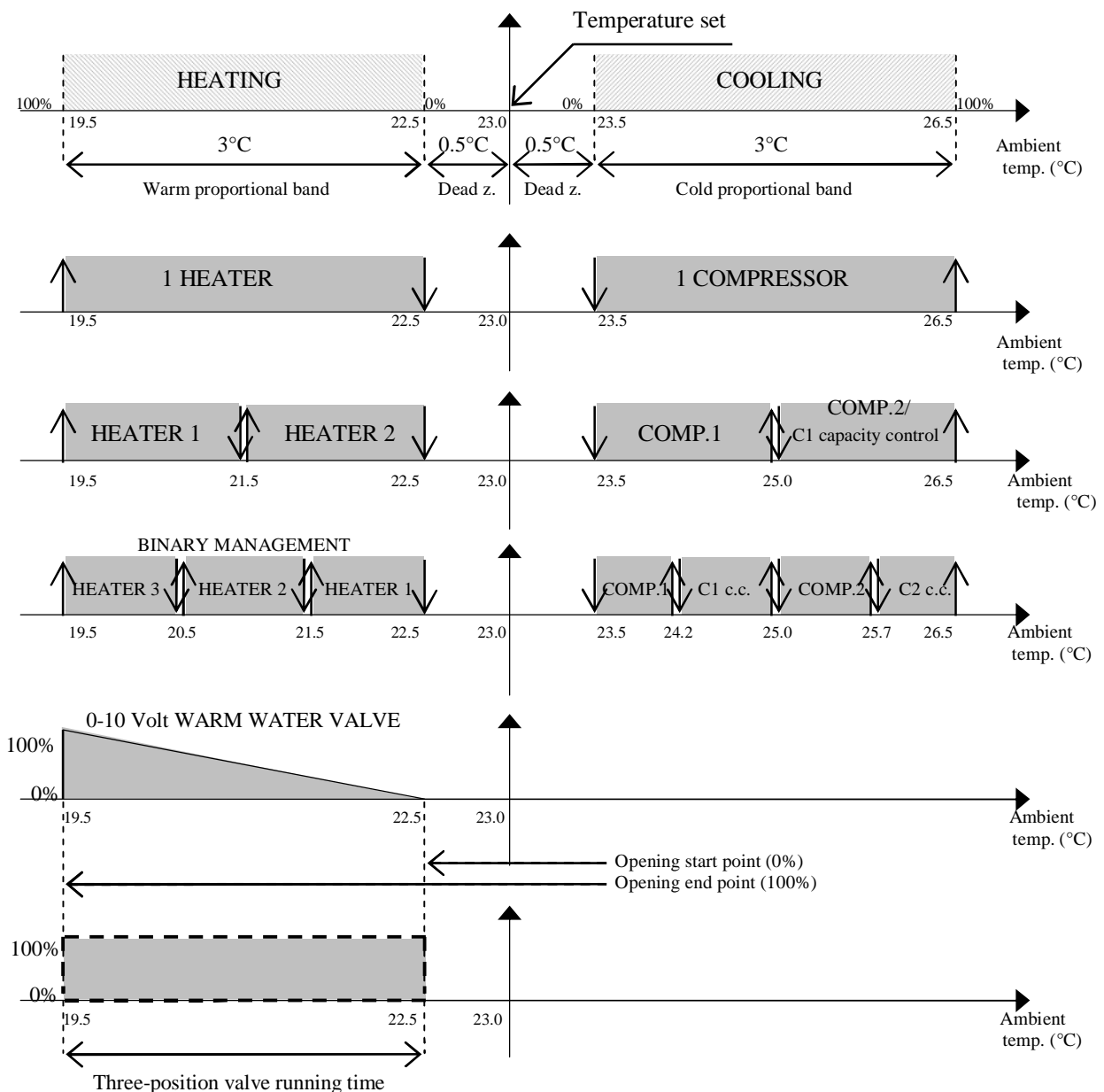

2.1.2 Other temperature functions

The high and low temperature alarms cause alarm screen signalling and have modifiable delay time. The dehumidification stop differential establishes the minimum temperature below which dehumidification is interrupted. Dehumidification can start again if temperature returns above the value established by the humidification start offset; differential and offset are modifiable.

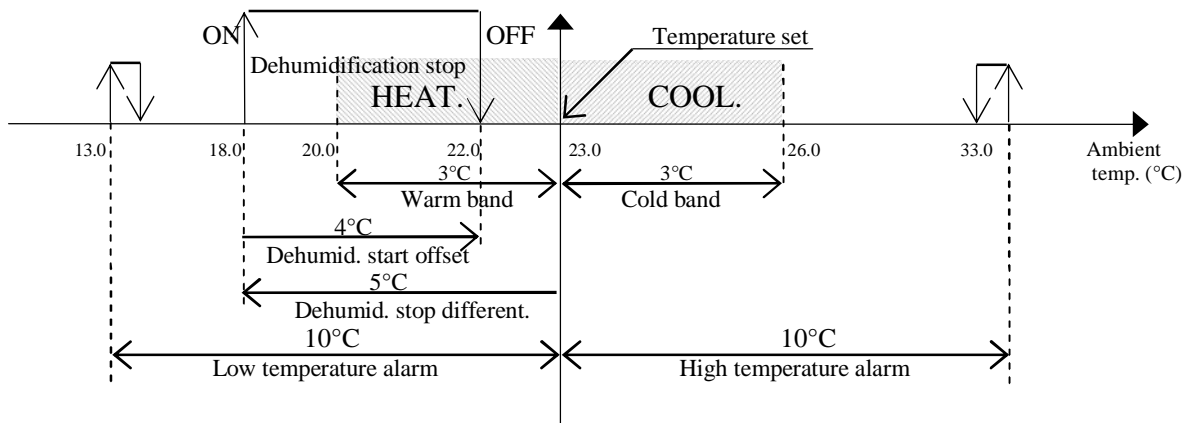

2.1.3 Close control units with two water coils

These close control units are equipped with a warm water coil and a cold water coil. In addition, heating can also be executed by heaters. The following diagram shows the cooling devices action, whereas the heating devices action is dealt with in the paragraph describing the direct expansion units.

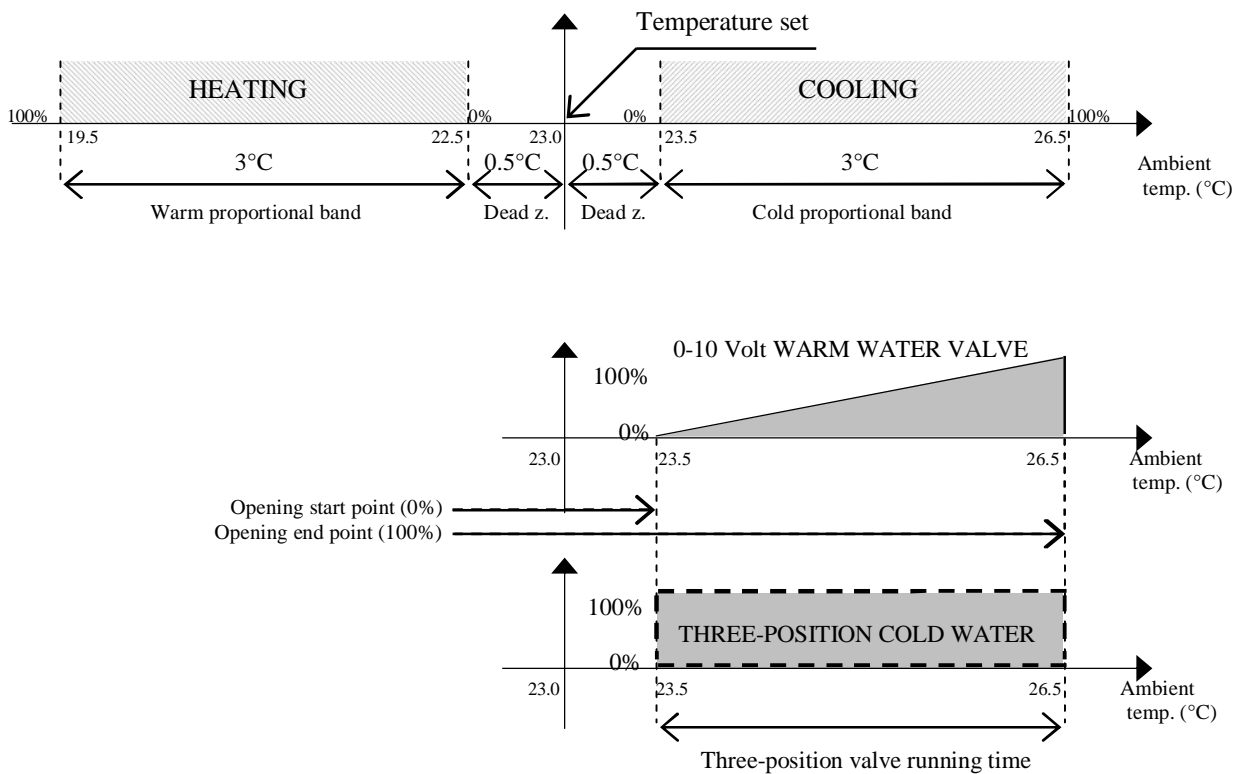

2.1.4 Close control units with single water coil

In these close control units, the coil provides for both heating and cooling, depending on the type of water circulating inside it. In practice, the unit works as it was equipped with two different coils. The coil operation depends from a Summer / Winter digital contact that “reports” whether the circulating water is warm or cold to the board; if the “type of water” circulating inside the coil complies with the ambient request, the valve is modulated to regulate temperature.

In addition, heating can also be executed by heaters or a warm coil. For any information about coil and heaters operation, refer to the previous paragraphs.

2.2 Humidity control

The humidification and dehumidification devices are managed based on the humidity value measured by the ambient (or room temperature) probe. The measured humidity is compared to the set humidity (set point); the devices are enabled based on the difference between the two values. The proportional band identifies the air-conditioning unit working range and can take different values in humidification and dehumidification mode. The 0.2% fixed dead zone identifies the devices non-action zone round the set point.

Dehumidification enables the available cooling devices and a contact for an external dehumidifier or for reducing the outlet fan speed.

Dehumidification can be executed as follows:

- On-Off contact for an external dehumidifier or for reducing the outlet fan speed
- compressors enabling (active capacity controls included, if any)
- 100% enabling of the 0-10Volt or three-position modulating cooling valve

The dehumidification On-Off free contact is always managed, whereas the cooling devices depend on unit configuration and User selection. The 0-10Volt modulating output of the dehumidification outlet fan is automatically reduced by 50% (modifiable); with On-Off fan, use the digital contact for reducing speed.

The following diagrams show the humidification and dehumidification devices action. The percentage values indicate the modulating valves opening range.

2.2.1 Close control units with direct expansion coil

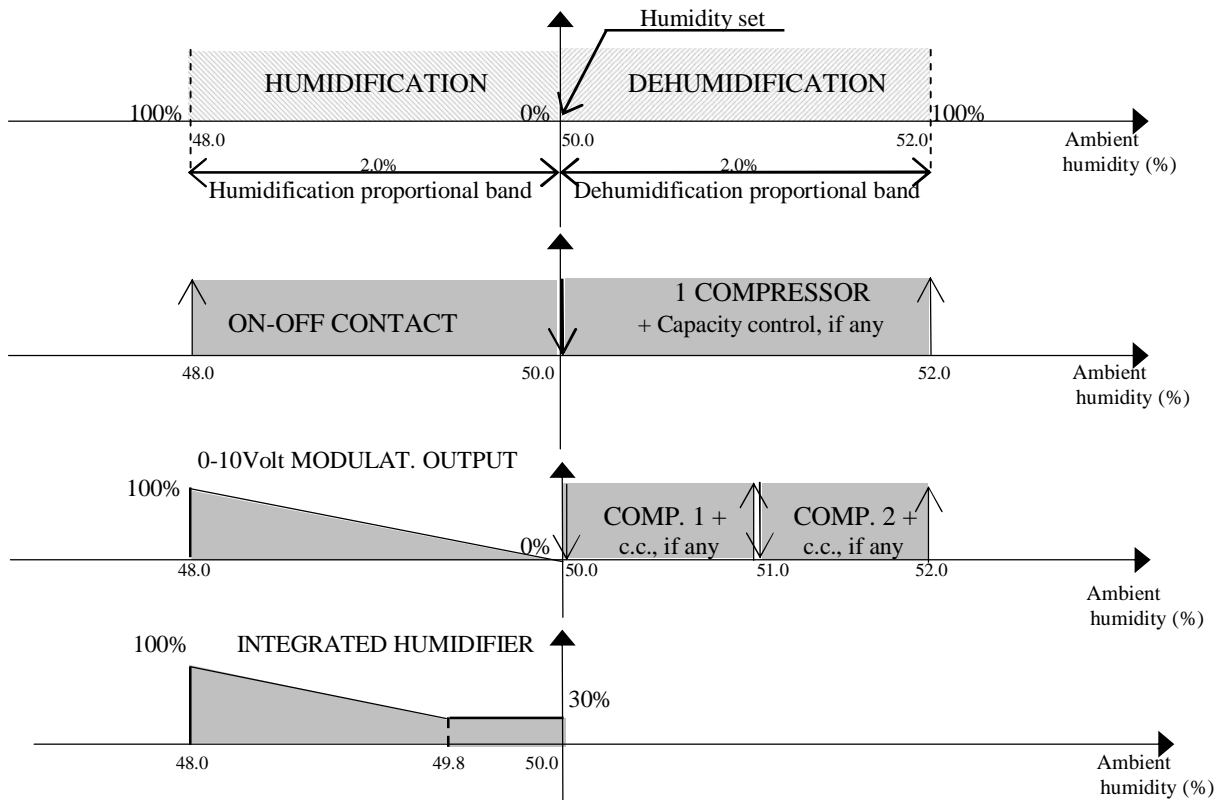

2.2.2 Other humidity functions

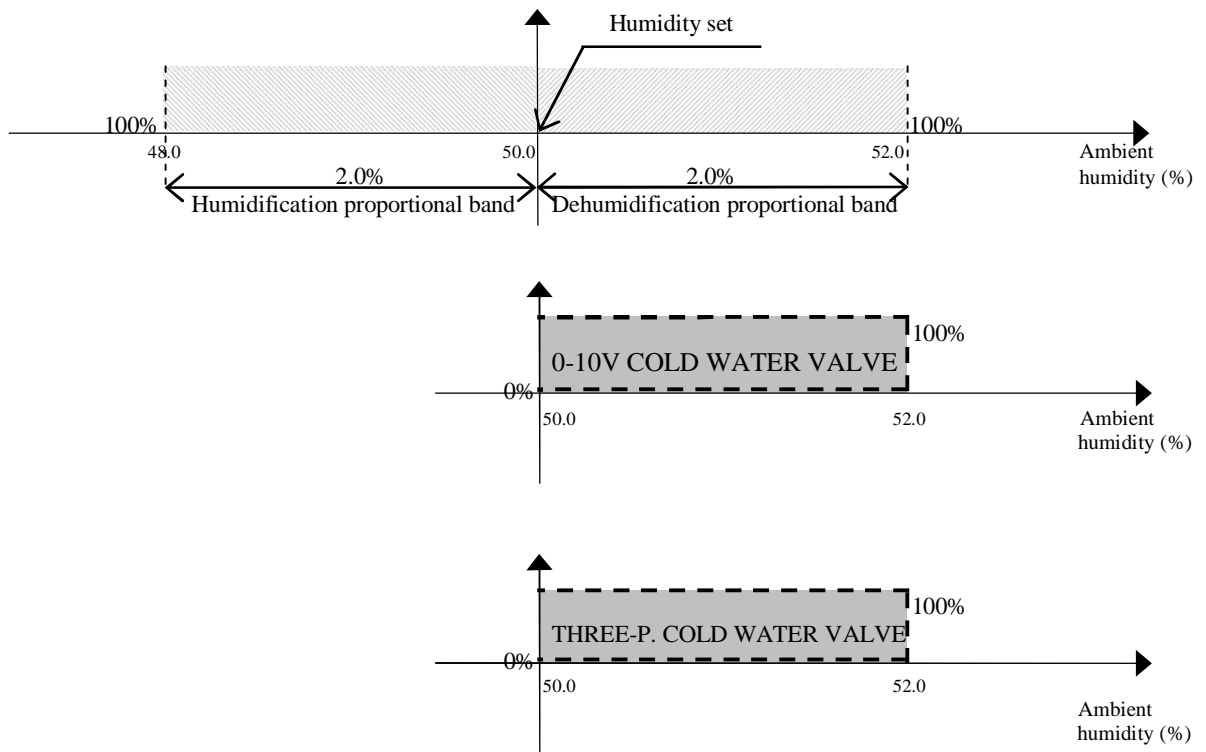

The high and low humidity alarms cause alarm screen signalling and have modifiable delay time.

2.2.3 Close control units with water coils

In these close control units, the cold water coils provide for dehumidification. For any information about their operation, refer to the previous paragraph. The following diagrams show the dehumidification devices action. The percentage values indicate the modulating valves opening range. Please note that the dehumidification cold water coils are enabled at 100%, not in modulating mode, in case of both three-position and 0-10Volt valves.

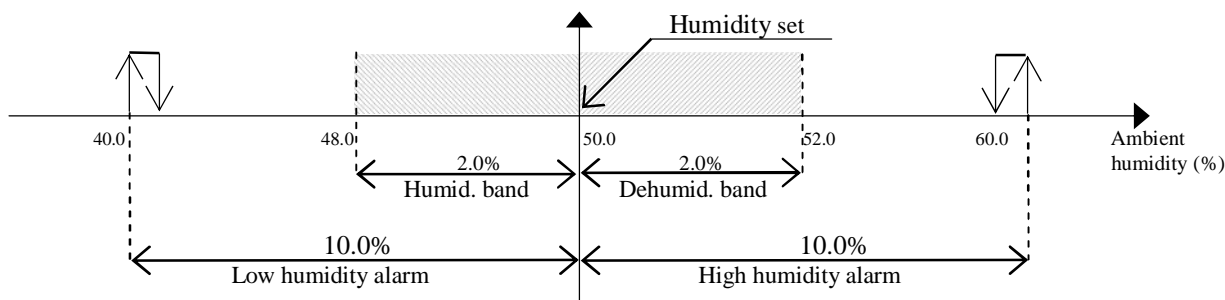

2.3 Recovery coil

Recovery is an optional function: an additional cold coil using water coming from an external source (i.e., evaporation tower) is enabled if the temperature of water running inside it is quite low. This allows saving on the system management costs. The coil is enabled by On-Off contact or 0-10Volt modulating signal. The following diagram shows the recovery coil enabling conditions: environment cooling request and recovery water temperature lower than recovery set – recovery differential.

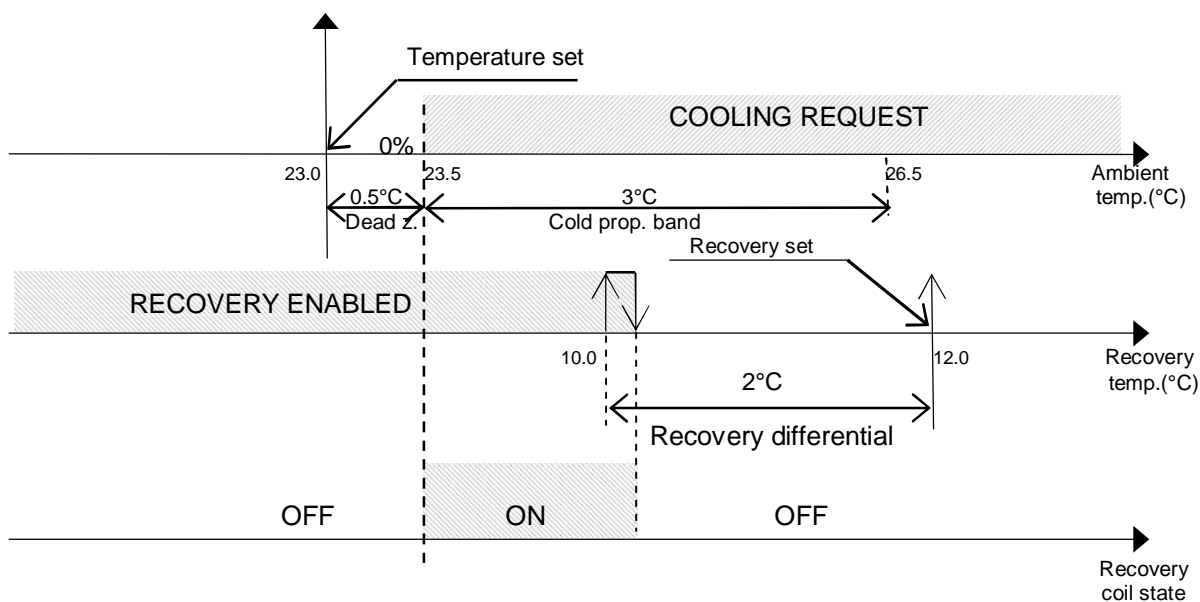

2.3.1 Recovery without cooling devices

As shown in the previous diagram, the recovery coil only is enabled, whereas the conventional cooling devices are not switched on; as it can be noted in the following diagram, the recovery coil takes up the entire cold proportional band.

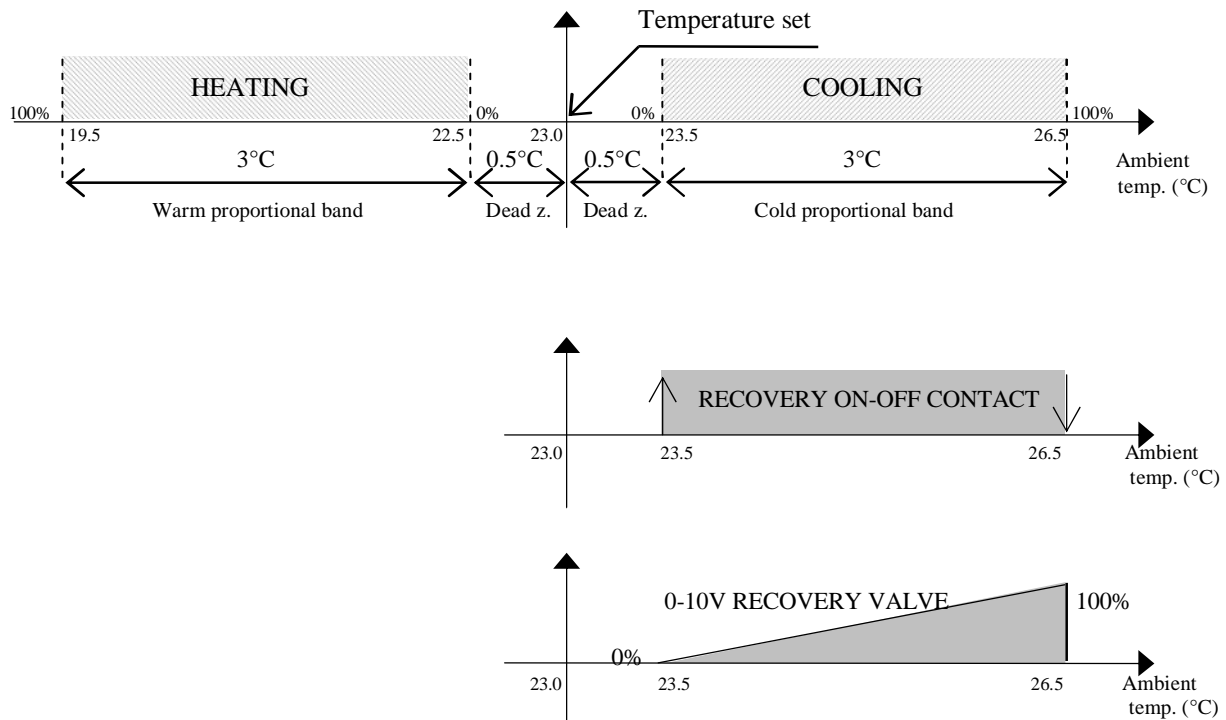

2.3.2 Recovery with cooling devices on close contr. units with direct expan. coil

With recovery coil enabled, the conventional cooling devices are switched on only if ambient temperature increases above a certain value; adding the effects of recovery coil and devices together, temperature decreases, but before reaching the set point, the cooling devices are switched off again. In this case, the cooling devices favour Recovery but do not substitute for it. The following diagram shows how the cooling devices steps are offset compared to normal position to ensure energy saving.

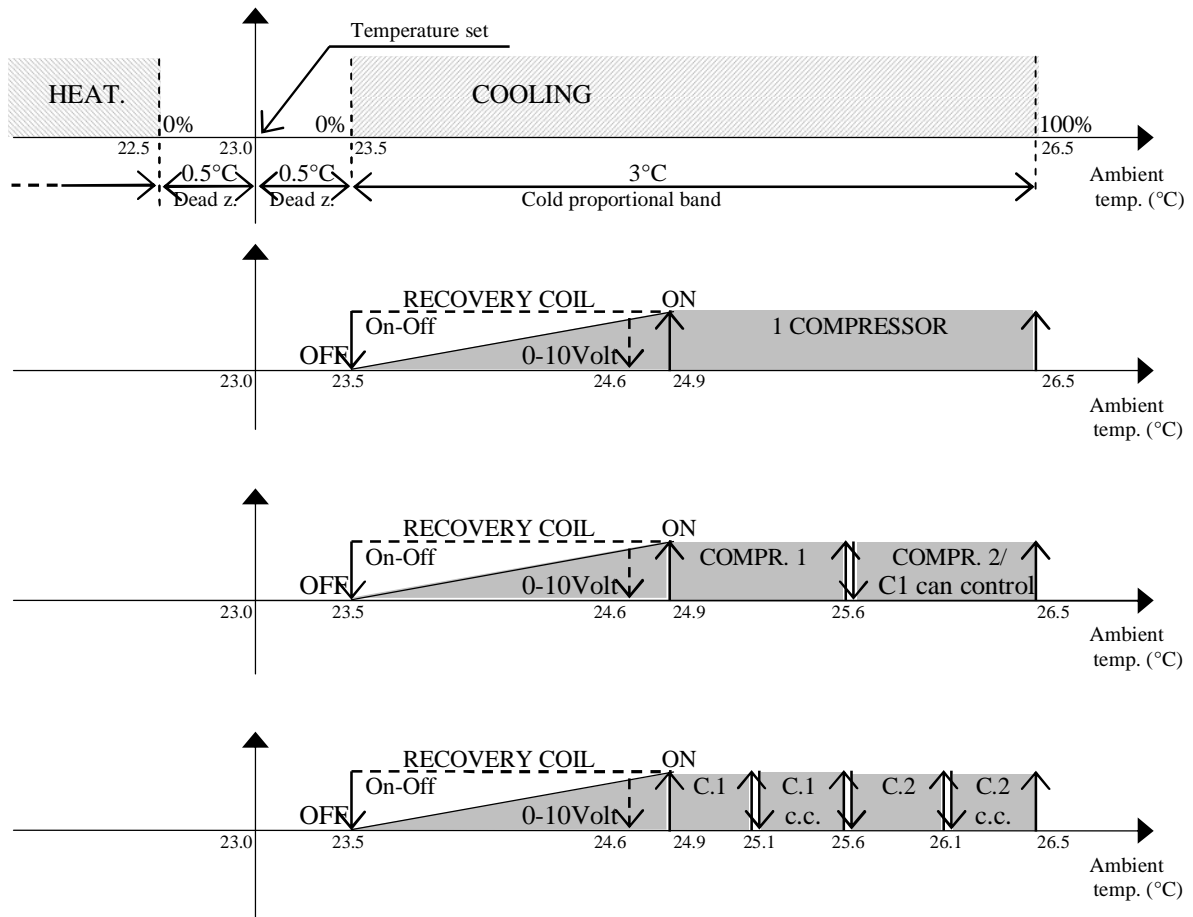

2.3.3 Recovery with cooling devices on close control units with water coils

The following diagram shows how the cold coil steps are offset compared to normal position to ensure energy saving.

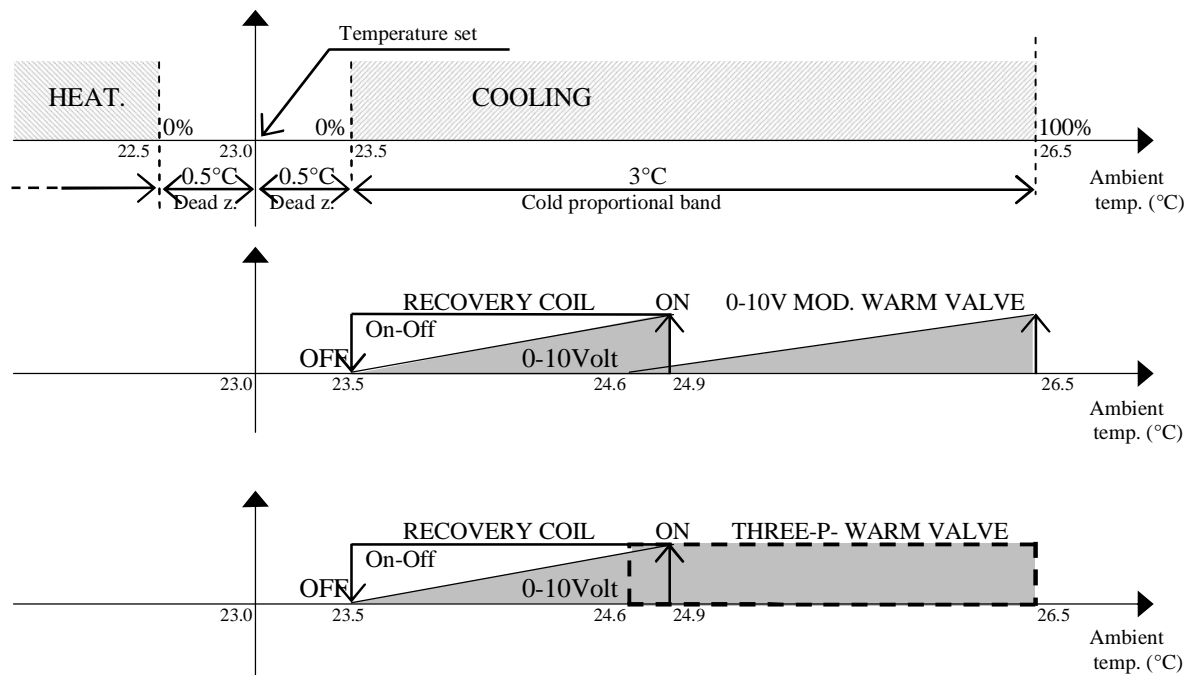

2.4 Outlet limit

This function prevents too cold air from circulating in the environment, thus safeguarding health of any exposed person. A temperature probe must be positioned on the air-conditioning unit outlet and parameters “Outlet set point” and “Outlet differential” shall be set. Such parameters identify a limiting zone, as shown in the following diagram:

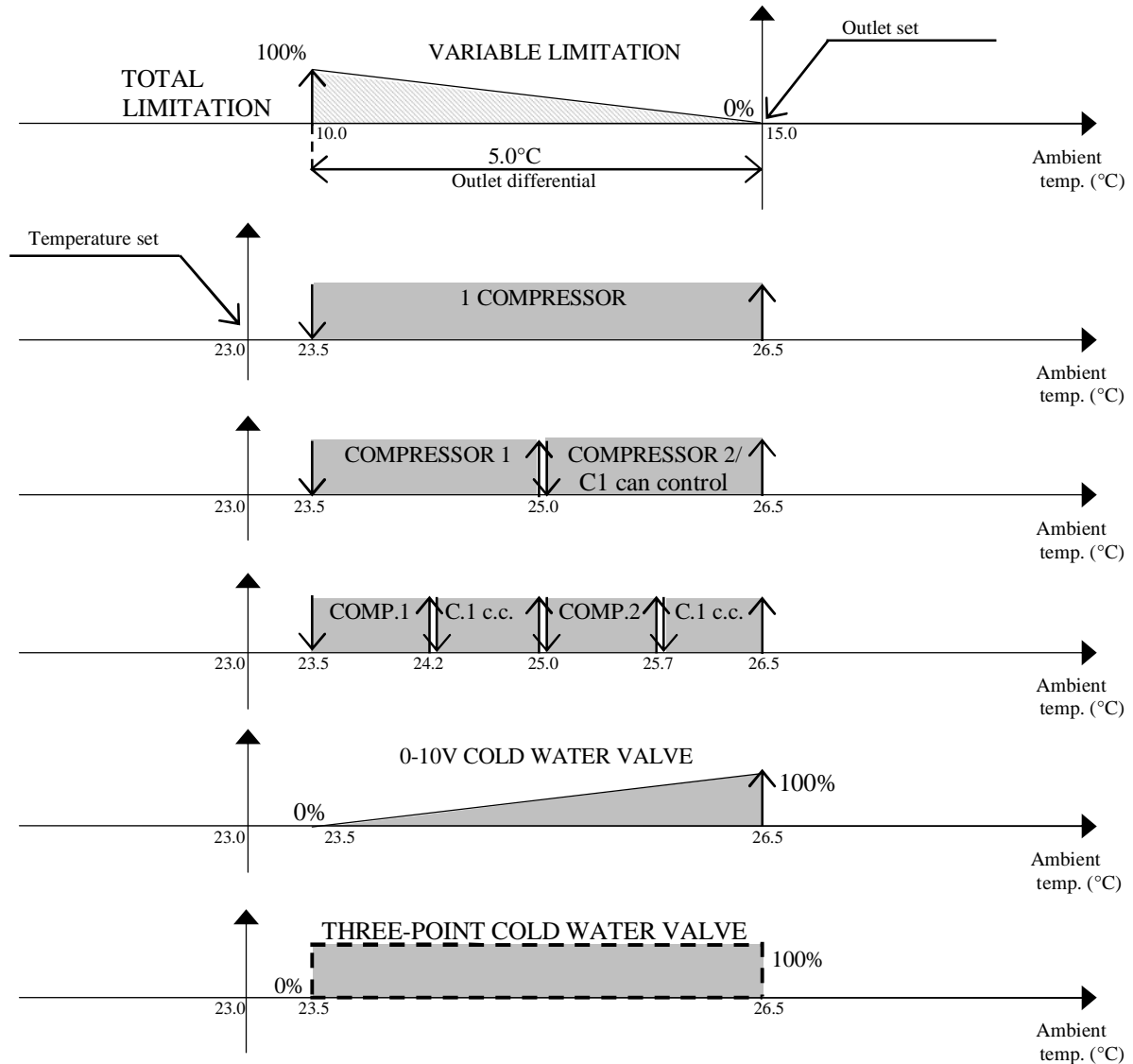

As shown in the diagram, if outlet temperature ranges between outlet set point and outlet differential, the cooling devices are limited only partially; the more temperature decreases the more limitation increases. As regards dehumidification limitation, the modulation zone is by-passed since dehumidification always needs the cooling devices maximum capacity. In practice, the devices are switched off only if outlet temperature is lower than differential; the devices are then switched on again if outlet temperature reaches the outlet set point, as shown in the following diagram:

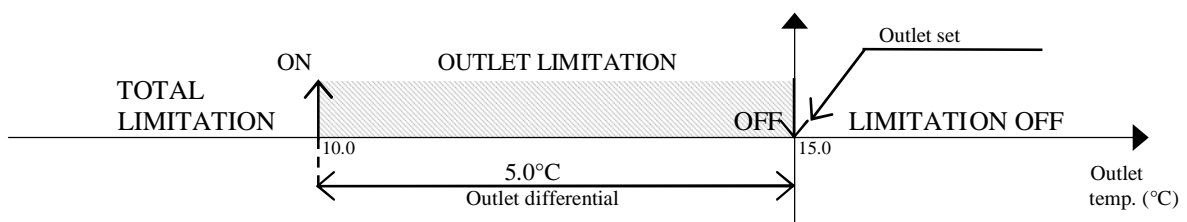

2.5 Condenser fans

Condensing pressure control is available on DX type units, in which fans are managed based on condensing coil pressure and compressors state. Fans are enabled by 0-10V modulating or digital outputs. Control is based on the condensation set point and differential, as shown in the following diagram:

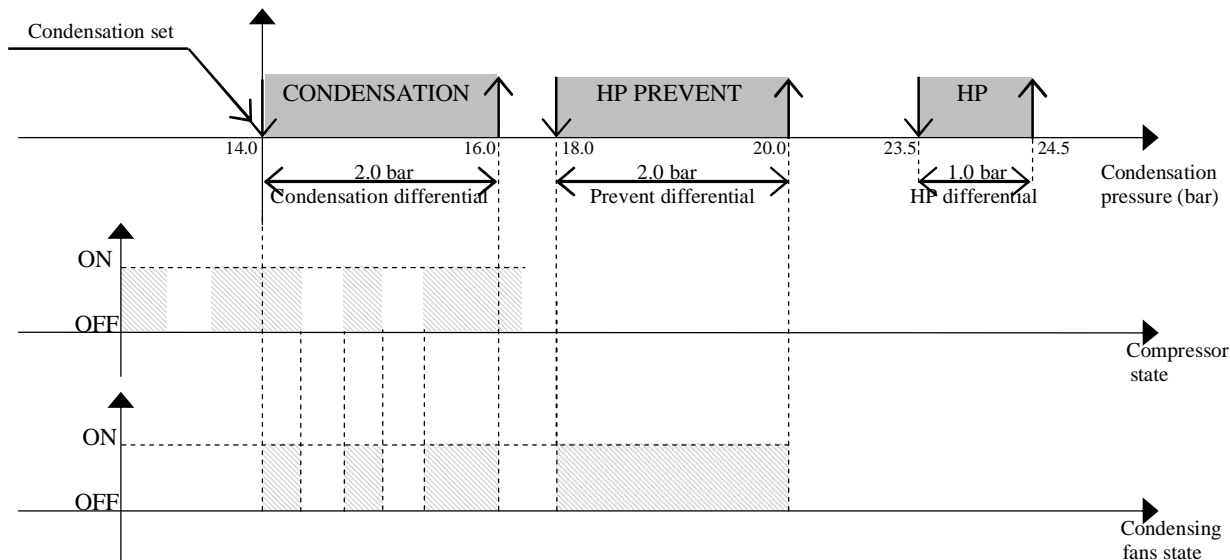

The following diagram shows fans operation with modulating outputs:

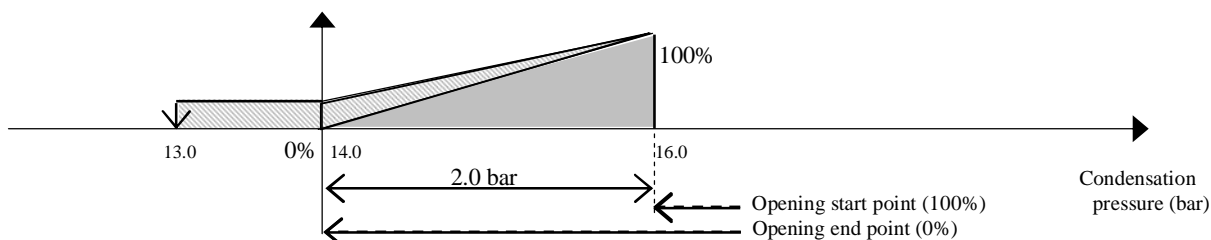

The maximum and minimum speeds of 0-10V outputs can be set; in case the set minimum speed is higher than 0V, the fan is operated at minimum speed 1.0 bar below the condensation set point before switching off, as indicated in the diagram above.

2.5.1 Single or separate coils

In case of single coil, only one output (on-off or modulating) is enabled. In case of units with at least one condensing probe and enabled on-off outputs, two on-off outputs may be enabled in sequence, dividing the differential by two.

In case of separated coils, two different outputs (on-off or modulating) are enabled, one per circuit.

2.5.2 Condensing pressure probes

Foreword: besides the values read by the probes, fans enabling always considers the compressors state.

In case of single probe and separated coils, fans enabling is based on the probe value for both circuits.

In case of two probes and single coil, fans enabling is based on the highest probes value.

In case of two probes and separated coils, fans enabling is based on the probe value of the relevant circuit.

In case no probe is present, fans are enabled simultaneously with the compressors; in case of single coil, fans are enabled when at least one compressor is on; in case of separated coils, each compressor controls the fans of its own circuit.

2.5.3 Prevent function

High pressure alarm prevention with compressors stopped. Normally, the condensing fans turn on only if compressors are enabled, but in this case they are forced so as to decrease pressure and try to prevent the high pressure alarm, which would cause unit shutdown. Pressure increase with compressors stopped may be due to radiance on the coil. In case of 0-10V modulating fans, modulation is by-passed.

2.5.4 Speed-up function

To overcome inertia at high-power modulating fans peak, they may be started at maximum speed for some seconds, then speed decreases to the required value and modulation starts.

2.5.5 Pressure – temperature conversion

Both pressure and temperature probes can be selected. In case of pressure probes, branch I/O screens display the temperature value corresponding to the pressure of each probe, based on the coolant type (to be selected in the Manufacturer branch).

2.6 Temperature set point compensation

The temperature set point can be “compensated” automatically for comfort reasons; for example, think about a commercial concern in which people frequently enter and go out: if internal temperature is 10°C lower than the external one, the thermal rush may annoy people and could be prejudicial to their health. The maximum difference between internal and external temperatures should not exceed 6°C in order to obtain optimum comfort. In this case, the compensation function increases the set point by 4°C, consequently increasing the ambient temperature; this function prevents the difference between internal and external temperature from exceeding 6°C.

Compensation requires a temperature probe to be installed at the exterior. The function is managed based on the values of compensation set point, differential and offset parameters, as shown in the following diagram:

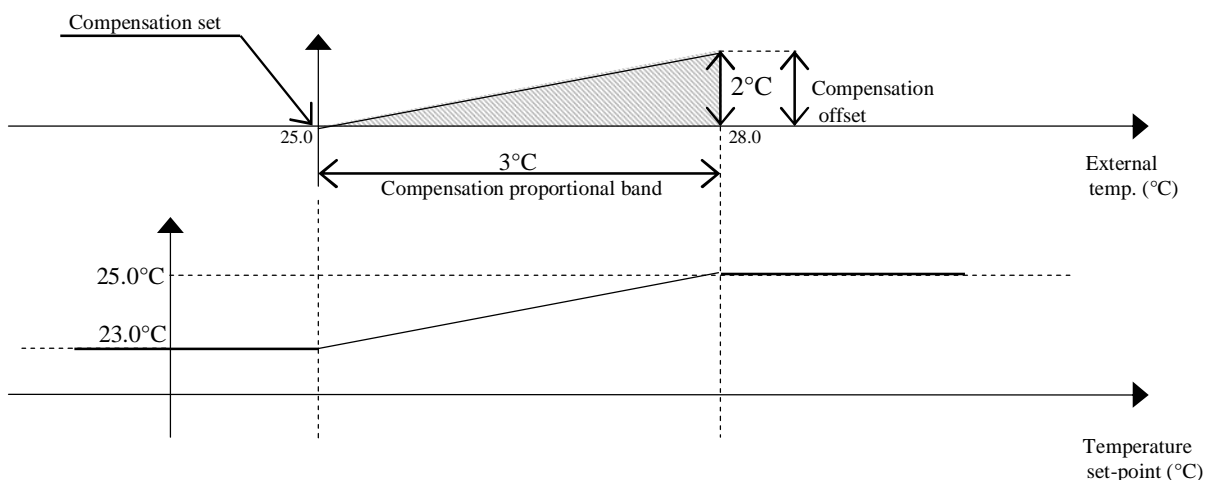

2.7 Compressors

Compressors are managed in ON-OFF mode. Maximum 2 compressors can be present.

2.7.1 Rotation

Compressors rotation follows the F.I.F.O. (first in, first out) logic. The first compressor turned on is the first to turn off, the first compressor turned off is the last to turn on. This logic allows comparing the compressors working hours and obtaining the same ageing. The rotation can be disabled.

2.7.2 Timing

START MINIMUM TIME

It represents the compressors start minimum time (in seconds) after they have been enabled. If a stop request arises, compressors are disabled only after the established time has elapsed.

STOP MINIMUM TIME

It represents the compressors stop minimum time (in seconds) after they have been disabled. If a start request arises, compressors are enabled only after the established time has elapsed.

MINIMUM TIME BETWEEN DIFFERENT COMPRESSORS STARTS

It represents the minimum time interval (in seconds) between start of a device and the following one. This interval allows preventing contemporary peaks, which would cause a high energy absorption.

MINIMUM TIME BETWEEN COMPRESSOR STARTS

It represents the minimum time interval (in seconds) between two starts of the same device. This parameter allows limiting the number of starts per hour. If, for example, the maximum number of starts per hour allowed by the default values is 10, this limit can be respected by setting a 360-second time interval.

2.7.3 Compressor alarms

Compressors alarms are distributed in two digital inputs, the alarms mean Thermal alarm / High and Low pressure alarm.

HIGH PRESSURE – THERMAL ALARM

Immediate alarm originated by external pressure switch or compressor overload; the digital input switches from closed to open and compressor is immediately stopped. To start the compressor again, the user has to rearm the alarm manually by pushing the display Alarm button, provided that the pressure switch or compressor overload have rearmed energising the digital input. After the compressor has turned off, timing is enabled; for this reason, after alarm rearming, the compressor could not immediately turn on again.

LOW PRESSURE ALARM

Delayed alarm originated by an external pressure switch. When opening, the digital input enables two timers; if, when the timers delay time (programmable by screen) elapses, the contact is open, the compressor turns off and the alarm goes off. On the contrary, if the contact closes before delay time elapses, the alarm does not go off and timers reset. Timers are: running compressor delay time and compressor start delay time. Running delay is always counted, whereas compressor start delay is counted only if the input opens immediately after compressor start and allows for fluid stabilisation. The two timers are counted in sequence.

To start the compressor again, the user has to rearm the alarm manually by pushing the display Alarm button, provided that the pressure switch has rearmed energising the digital input. After the compressor has turned off, timing is enabled; for this reason, after alarm rearming, the compressor could not immediately turn on again.

GENERIC ALARM

Alarm including all compressor safety devices in a single digital input, used on two-compressor small boards. This alarm goes off immediately when opening the digital input and locks the compressor. To start the compressor again, the user has to rearm the alarm manually by pushing the display Alarm button, provided that the digital input has been energised. After the compressor has turned off, timing is enabled; for this reason, after alarm rearming, the compressor could not immediately turn on again.

2.8 Heaters

The heaters are managed as simple ON-OFF loads. Normally up to 2 heaters with the same power can be managed, connected to the 2 outputs.

“Binary management” allows the use of three heating steps with just two outputs and 2 loads with different power values:

The outputs with binary logic behave as follows:

	2 DIFFERENT LOADS
STEP 1	Heat.1 = On / Heat.2 = Off
STEP 2	Heat.1 = Off / Heat.2 = On
STEP 3	Heat.1 = On / Heat.2 = On

The outputs are activated with a slight delay from one to the other, to avoid simultaneous peaks.

2.8.1 Heater alarms

Each heater is provided with a digital input to be connected with a compressor overload or differential for signalling any failure.

Immediate alarm originated when the digital input switches from closed to open; the heater is immediately disabled. To enable the heaters again, the user has to rearm the alarm manually by pushing the display Alarm button, provided that the compressor overload or the differential have rearmed energising the digital input.

2.9 Modulating valves

2.9.1 Three-position valves

Valves with three electrical contacts (besides supply): shared, opening and closing.

Based on the relays enabling time, the valves opening range varies from 0% to 100% taking an opening/closing time defined as “running time” (time taken to open or close completely; it is a valves rating). The relays must never be enabled simultaneously, thus the valve open, close or keep still.

The valves opening range is calculated based on the proportion between temperature differential and running time. When ambient temperature corresponds to the set point, the valves keep closed; the more temperature is offset compared to the set point the more the valves are opened, until they open completely when temperature is equal or higher than set point + / - differential.

During operation, the valves are frequently subject to partial opening and closing; the program can recognise the valves opening range at any time by adding up and subtracting all partial times executed from board start-up.

REALIGNMENT

As there is no feedback to define precisely the valves opening range, the program cannot easily manage the three-position valves. A slight difference between the time calculated by the program and the relays enabling time or a mechanical friction preventing the valves from moving freely may originate discrepancy between the valves actual opening range and the range calculated by the program. To obviate this problem, the following precautions are provided for:

- whenever temperature control requires a valve complete opening or closing, the program increases the opening or closing relay enabling time by 25% to ensure complete opening/closing.
- whenever the board is started, the valves are completely closed during the running time; only after time has elapsed, the valves start modulating their opening range based on the control request.

2.9.2 0-10Volt VALVES

These valves use a 0-10Volt modulating signal coming from the microprocessor to modify their opening range from 0% to 100%.

The 0-10Volt electric signal is directly proportional to the temperature proportional band. Unlike the three-position valves, these valves do not require adjustment since their opening range is directly proportional to the analogue output value.

2.10 Outlet fan

With unit enabled, the outlet fan keeps switched on. It can be managed with On–Off or modulating output. The fan is provided with a thermal alarm and an air flow controller alarm, which lock the unit setting it to OFF state; thermal alarm requires manual rearm, whereas air flow controller alarm is rearmed automatically. Description of modulating management:

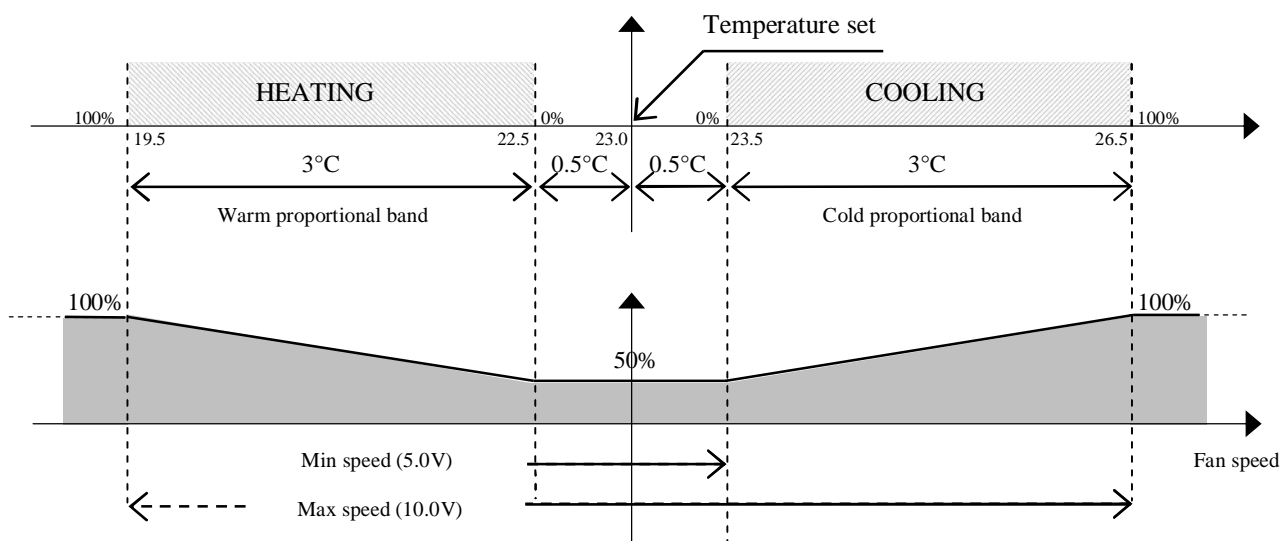

3 THE USER INTERFACE

The provided user interface PGD is equipped with a LCD display (4 rows x 20 columns). and with 6 keys. It allows carrying out all program operations. The user interface allows displaying the unit working conditions at any time and modifying the parameters; furthermore, it may also be disconnected from the main board, as its presence is not strictly necessary.

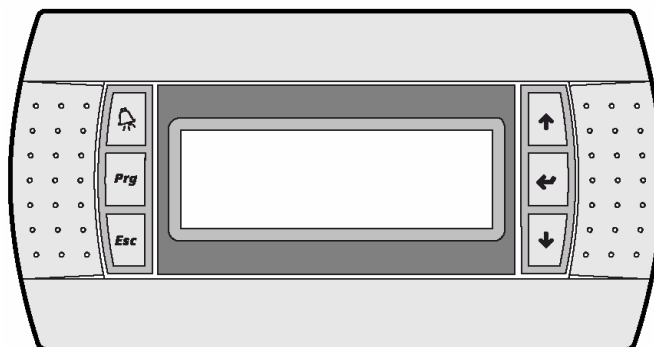

3.1 Keyboard description

The PGD user interface has 6 keys and their use is describe in the following table.

	Keys	Description
	ALARM key	Press ALARM key to enter the alarm menu and to reset the alarms. When an alarm is present the button is illuminated.
Prg	PROGRAM key	Press PROGRAM key to enter the main menu where is possible to select the items: MAINTENANCE, PRINTER, INPUT/OUTPUT, CLOCK, SETPOINT, USER, MANUFACTURER
Esc	ESC key	Press ESC key to go out from a menu and come back into the main screen.
	UP key	Press UP key to move into the next screen or to increment the value of a parameter.
	ENTER key	Press ENTER key to move into the next modifiable parameter field and confirm the modification
	DOWN key	Press DOWN key to move into the previous screen or to decrement the value of a parameter.
Prg + Esc	PROGRAM + ESC keys	Press simultaneously PROGRAM and ESC keys to enter directly the MANUFACTURER menu.
Esc + 	ESC + ENTER keys	Press simultaneously for 5 seconds, ESC and ENTER keys to enter into the screen where you can press ENTER to switch ON/OFF the unit

3.1.1 Switch ON/OFF of the unit

The unit is switch On/Off by pressing Esc + Enter keys simultaneously for 5 seconds; after, the displayed screen allows executing the required operation by using Enter key.

3.1.2 Screen loop

Press PROGRAM key to display the main menu; then, by using the arrow buttons, move the cursor on the selected item and press Enter to access it.

3.2 Remote user interface

3.2.1 Without local display

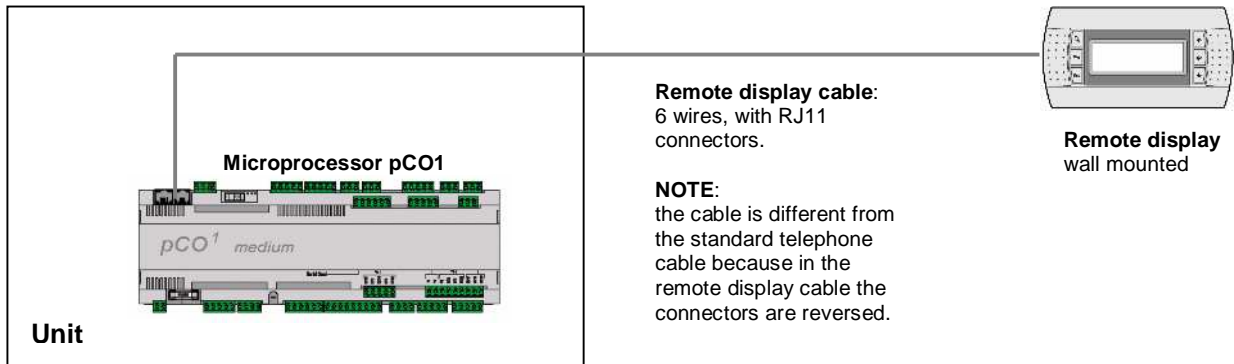

3.2.2 With local display

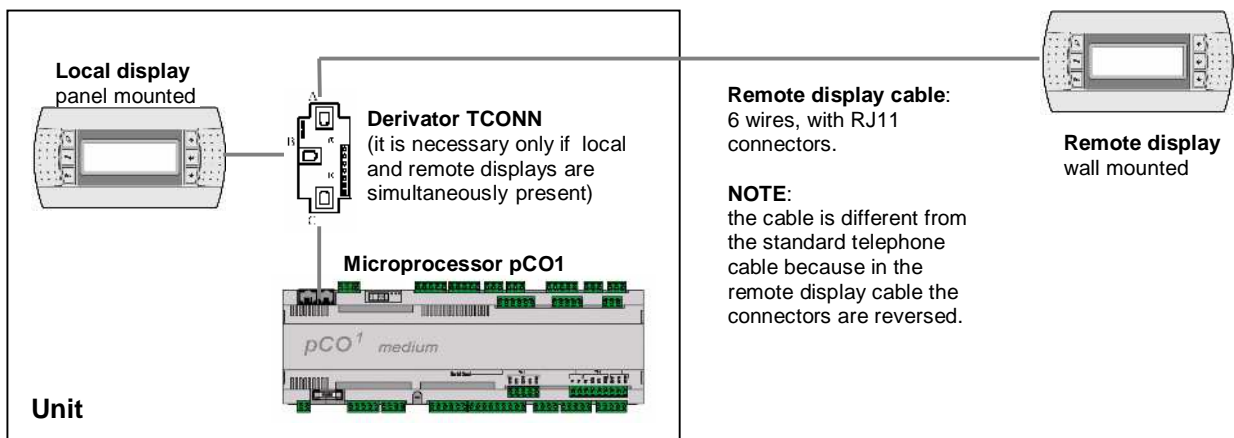

4 BOARD CONFIGURATION AND CONNECTION

The LAN network identifies a physical connection between the microprocessor, the display and the drivers for the electronic expansion valves. This connection allows exchanging variables from a board to another, according to a logic established by the software, to make them work together in a functional way. The address of the boards must be configured even in stand alone unit.

4.1 Address configuration

4.1.1 Address configuration of the microprocessor (pCO1)

For the configuration of the address of the pCO1 follow these steps:

- connected the pCO1 with a display PGD with the address configure to 0. (See Address configuration of the PGD)
- switch ON the power supply pressing simultaneously the ALARM and the UP keys.
- press UP or DOWN key to set the address.
- press ENTER key to save and exit from this procedure.

4.1.2 Address configuration of the PGD

For the configuration of the address of the PGD follow these steps:



- press UP+ENTER+DOWN for few seconds
- press ENTER and then press UP or DOWN key to set the address.
- press ENTER key to save and exit from this procedure.

NOTES:

- If the addresses of the microprocessor or of the PGD are non corrected, the functioning of the unit is not guaranteed, and the PGD can displays nothing.
- after the address configuration of the PGD, it can display the notice "NO LINK" for some seconds.

4.1.3 Address configuration of the E2V electronic expansion valve's driver (EVD)

For the configuration of the driver (EVD) is necessary to set the dip-switch (using a binary logic) that are present inside of the driver, under the frontal box.:

	Address	Dip-switch
Driver for circuit 1	9	 ON OFF
Driver for circuit 2	10	 ON OFF

Open the frontal box to configure the dip-switch.

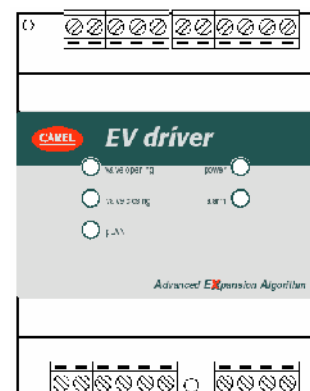

4.2 Boards connection

The electrical connection among boards is executed using the following two type of cables:

Display connection

For the connection of the display is necessary to use a cable with 6 wires and RJ11 connectors; the cable is different from the standard telephone cable because in the display cable the connectors are reversed.

LAN connection

For the LAN connection is necessary to use a cable with 2 wires plus shield, from unit to unit, by using the terminal strip in the electrical panel (see the specific electrical diagram); the data are sent through Rs485 logic; no additional device is required.



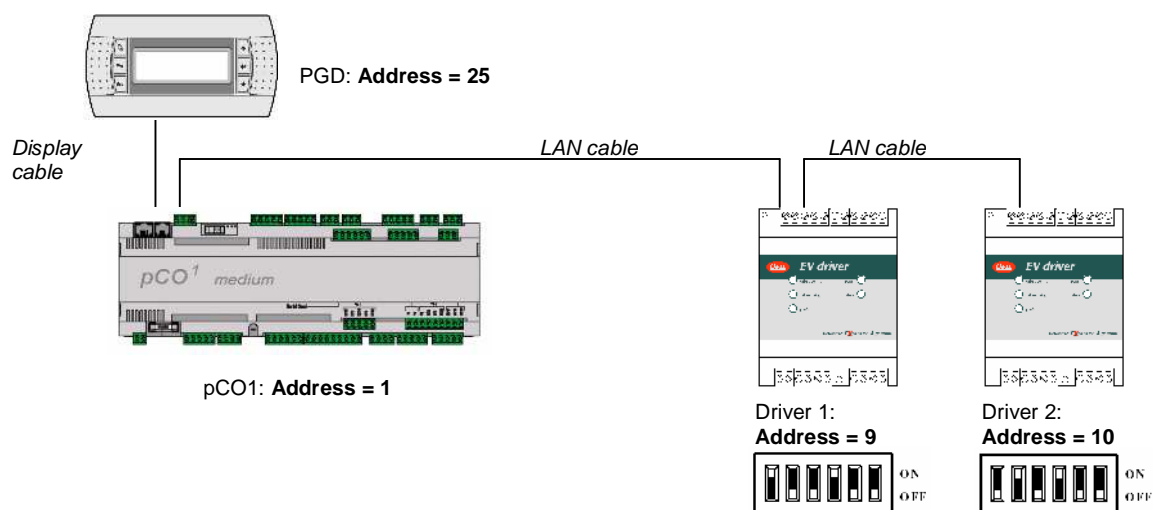



4.2.1 Stand alone unit



4.2.2 Units connected in LAN (max. 8 units)

The units can be connected to the other units in LAN (local area network) for a maximum of 8 units. Each unit can be connected (inside of it) to one or two drivers (EVD) for the management of the electronic valves and to one display for user interface. In the following table are listed the addresses of the microprocessor, of the drivers (EVD) and of the display.

	List of addresses			
	Address of Microproc. pCO1	Address of EVD Driver 1	Address of EVD Driver 2	Address of Display
	<i>Config. by display</i>	<i>Config. by dip-switch</i>	<i>Config. by dip-switch</i>	<i>Config. by display</i>
Unit 1	1	9	10	25
Unit 2	2	11	12	26
Unit 3	3	13	14	27
Unit 4	4	15	16	28
Unit 5	5	17	18	29

Unit 6	6	19	 ON OFF	20	 ON OFF	30
Unit 7	7	21	 ON OFF	22	 ON OFF	31
Unit 8	8	23	 ON OFF	24	 ON OFF	32

The address of the microprocessor can be read from the main screen in the lower right corner.

The **display with address 32** allows controlling all boards without requiring other displays or in addition to the other displays; as a matter of fact, the program allows display with address 32 to access the parameters of all connected boards, one by one. Passage among the boards can be executed by simply pushing button ESC + DOWN.

4.2.3 LAN status

When starting the system, the LAN network could undergo some problems (failed boards and displays start-up) due to improper electrical connections or to the fact that incorrect addresses have been assigned. By means of a special screen, the LAN network state can be displayed in real time, thus identifying which devices (boards and displays) are properly connected and addressed. To display the special screen, push buttons Up-Down-Enter of any network display simultaneously for at least 10 sec. After the first 5 seconds, a screen is displayed; continue for another 5 seconds until the following screen is displayed:

```

NetSTAT 1  _ _ _ _ _ _ _ _ 8
T: 25 9 _ _ _ _ _ _ _ _ 16
Enter 17  _ _ _ _ _ _ _ _ 24
To Exit 25  _ _ _ _ _ _ _ _ 32
  
```

As it can be seen, network addresses from 1 to 32 are displayed, together with a symbol indicating if a display (small rectangle) or a board / valve driver (big rectangle) is concerned. The dash indicates that the board / display has incorrect address or is connected improperly. In case the symbols appear and disappear, it means that LAN is unstable or, more probably, that repeated addresses are present. The number following T indicates the address of the display being used. The example indicates that the network consists of one boards or valves drivers with address 1 and of one display with address 25. After the screen is checked, if there is some trouble cut network power off, verify connections and addresses and power the system again.

4.3 Software update

If is necessary a software update the boards shall be programmed by DOWNLOADING the application program to the Flash buffer memory; this operation can be performed either using the hardware key or a computer.

4.3.1 Program download from hardware key

To connect the key to the pCO1, proceed as follows:

1. Switch the pCO1 off and remove the "expansion memory" cover using a screwdriver.



2. Place the key selector on .

3. Insert the key into the corresponding slot.
4. Press Up and Down together in the display and switch the board on.
5. Check that the red key LED comes on.
6. Wait until the upload request is displayed on the LCD, then release the buttons and confirm by pressing Enter; the data transfer operation will take approximately 10 seconds.
7. Switch the pCO1 off, remove the key, place the cover in its original position and switch the board back on again.
8. The board will now work with the program transferred from the key.

4.3.2 Program download from computer

Use the the converter (RS232/RS485) and the WinLOAD 32 program, proceeding as follows:

1. Connect the converter (RS232/RS485) to the mains using the transformer provided in the kit.
2. Connect the converter to a free serial port on the PC, using the serial cable provided in the kit.
3. Connect the converter to connector J10 on the pCO1 using a telephone cable.
4. Install Winload, if Winload is not already installed on the PC.
5. Run WinLOAD32 on the PC, with the board off.
6. Enter in the number of the PC serial port in the field "COMM" (1 for COM1, 2 for COM2).
7. Enter "0" in the field "pCO ADD."
8. Switch the board on.
9. Wait 30 seconds until the message "OFF LINE" becomes "ON LINE" in the WinLOAD32 program, in the lower left, or until the yellow LED next to the dipswitch on the board starts flashing; now enter the actual board LAN address value in the field "pCO² ADD"; a blue light in the Winload program, in the bottom centre of the window, will start flashing.
10. In WinLOAD32, select "Upload" and then "Application".
11. Select the folder containing the application program source files.
12. Use CTRL to select a series of *.iup files, if needing to load a series of languages to the pCO1. Also select the *.blb files (for non-LAN applications) or the flash1.bin file in the program being loaded (for LAN applications).
13. Click "UPLOAD" to start the file download procedure, which will take approximately 1 to 5 minutes, depending on the number of *.iup files selected and the size of the various files.
14. Wait until the message "Upload OK" appears in the progress bar.
15. Disconnect the telephone cable between the board and converter; connect the external display (if featured), then switch the board off and on again.

NOTE: if a LAN network with a series of boards is used, the program can be installed on the other boards without repeating the operations: after installing the program on the first board, simply repeat steps from 8 to 14, entering the new board addresses each time in the field "pCO ADD" in the WinLOAD32 program.

4.3.3 Restore the default parameters

Default parameters are the values assigned by manufacturer to the application program main operative parameters. Parameters are assigned automatically when executing the DOWNLOAD operation as described above. Parameters indicate timing, set points, differentials, etc... (refer to the complete list of default values).

After installing default values, the parameters must be modified following the special parameter list with the specific parameter of the installed unit.

Operations to be carried out for default parameters manual installation:

1. Push buttons PRG + ESC keys and type the Manufacturer password, then push Enter.
2. By pushing button Down three times, move the cursor on "INITIALIZATION" (last row), then push ENTER.
3. The parameters installation screen is displayed; to install, push ENTER and type the Manufacturer password.
4. **WARNING:** we recommend extreme care since this operation deletes all the installed parameters from the memory and replaces them by the default parameters – after this operation, parameters cannot be restored.
5. After pushing ENTER, message "PLEASE WAIT" is displayed for some seconds.
6. Switch off and then switch on the power supply.

4.3.4 Language selection

English is the language automatically selected, but it can be changed into: Italian, French, German, Spanish. To modify the language, operate as follows:

1. Press the PROGRAM key, select the MAINTENANCE item and press ENTER
2. Press ENTER in the screen A0, and UP or DOWN to modify the language
3. Press ENTER to confirm the new language.

5 ALARMS

The alarms managed by the program safeguard soundness of the connected devices and provide signals in case the control parameters have exceeded the normal values or the board is faulty. The alarms originate from alarm digital inputs, probes or board. Their effect ranges from the simple block signalling of one or more devices to the air-conditioning unit stop. Many alarms are subject to programmable delay times.

When an alarm state is identified, the following signals occur:

- the red LED under button ALARM turns on
- abbreviation AL starts blinking on the Menu screen

Pushing button Alarm, the buzzer switches off and the alarm screen is displayed. If more alarms are active, the screen of the first alarm is displayed; the other alarms can be displayed by using the arrow buttons. If other buttons are pressed, the alarm screens are left but they keep stored and are displayed again whenever the Alarm button is pressed.

To rearm the alarms and delete the message manually, simply move the cursor on the alarm screens and push button Alarm again; if the alarm causes have disappeared (digital inputs rearmed, temperature within the normal values, etc...), the screens disappear, the red led switches off and message "NO ALARM ACTIVE" is displayed. If the cause of one or more alarms is still active, the disabled alarms only disappear, whereas the other alarms keep displayed and the buzzer and the red led switch on again.

Alarms are divided into two categories: manually-rearmed alarms or automatically-rearmed alarms.

The manually-rearmed alarms require alarm screen deleting (as described above) to restart the devices or the air-conditioning unit. The automatically-rearmed alarms unlock the device or restart the air-conditioning unit after the cause has disappeared, but the alarm screen keeps stored in the memory.

5.1 Table of alarms

CODE	DESCRIPTION	DELAY	UNIT OFF	DISABLED
A01	Compressor 1 general alarm	-	-	Compressor 1
A02	Compressor 2 general alarm	-	-	Compressor 2
A03	Compressor 1 low pressure	see T2	-	Compressor 1
A04	Compressor 2 low pressure	see T2	-	Compressor 2
A05	No air flow	see T4	yes	All
A06	Outlet fan thermal	-	yes	All
A07	Heater 1 thermal	-	-	Heater 1
A08	Heater 2 thermal	-	-	Heater 2
A09	Fire / Smoke detection	-	yes	All
A10	Dirty filters	-	-	-
A11	High ambient temperature	see T2	-	-
A12	Low ambient temperature	see T2	-	-
A13	High ambient humidity	see T2	-	-
A14	Low ambient humidity	see T2	-	-
A15	Compressor 1 working hours threshold reached	-	-	-
A16	Compressor 2 working hours threshold reached	-	-	-
A17	Outlet fan working hours threshold reached	-	-	-
A18	Ambient temperature probe faulty or disconnected	60 sec (fixed)	-	-
A19	Recovery water temperature probe faulty or disconnected	60 sec (fixed)	-	-
A20	External air temperature probe faulty or disconnected	60 sec (fixed)	-	-
A21	Outlet air temperature probe faulty or disconnected	60 sec (fixed)	-	-
A22	Ambient humidity probe faulty or disconnected	60 sec (fixed)	-	-
A23	Condenser 1 pressure probe faulty or disconnected	60 sec (fixed)	-	-
A24	Condenser 2 pressure probe faulty or disconnected	60 sec (fixed)	-	-
A25	Condenser 1 temperature probe faulty or disconnected	60 sec (fixed)	-	-
A26	Condenser 2 temperature probe faulty or disconnected	60 sec (fixed)	-	-
A27	High humidifier current	-	-	Humidifier

A28	No water inside humidifier cylinder	?	-	-
A29	No current in humidifier	?	-	-
A30	Clock card not present / faulty	-	-	-
A31	Circuit 1 high pressure	-	-	Compressor 1
A32	Circuit 2 high pressure	-	-	Compressor 2
A33	Water under floor	-	yes	All
A34	Auxiliary alarm	-	-	-
A35	Compressor 1 high pressure + thermal	-	-	Compressor 1
A36	Humidifier working hours threshold reached	-	-	-
A37	Compressor 2 high pressure + thermal	-	-	Compressor 2
A38	Condensing fan 1 thermal	-	-	Condensing fan 1
A39	Condensing fan 2 thermal	-	-	Condensing fan 2
A40	No water flow	see T4	yes	All
A41	pLAN disconnected	60 sec (fixed)	-	-
A42	Driver 1 alarm, probes faulty or disconnected	-	-	Compressor 1
A43	Driver 1 EEPROM faulty or damaged	-	-	Compressor 1
A44	Driver 1 valve motor faulty or damaged	-	-	Compressor 1
A45	Driver 1 alarm, battery discharged or faulty	-	-	-
A46	Driver 1 high evaporation pressure (MOP)	See Fj	-	-
A47	Driver 1 low evaporation pressure (LOP)	See Fj	-	-
A48	Driver 1 low superheating	See Fi	-	Compressor 1
A49	Driver 1 valve not closed during blackout	-	-	Compressor 1
A50	Driver 1 high suction pressure	See Fi	-	-
A51	Driver 2 alarm, probes faulty or disconnected	-	-	Compressor 2
A52	Driver 2 EEPROM faulty or damaged	-	-	Compressor 2
A53	Driver 2 valve motor faulty or damaged	-	-	Compressor 2
A54	Driver 2 alarm, battery discharged or faulty	-	-	-
A55	Driver 2 high evaporation pressure (MOP)	See Fj	-	-
A56	Driver 2 low evaporation pressure (LOP)	See Fj	-	-
A57	Driver 2 low superheating	See Fi	-	Compressor 2
A58	Driver 2 valve not closed during blackout	-	-	Compressor 2
A59	Driver 2 high suction pressure	See Fi	-	-
A60	Built-in humidifier: high conductivity alarm	See threshold Gb: delay 1h	-	Humidifier
A61	Built-in humidifier: high conductivity pre alarm	See threshold Gb: delay 1h	-	-
A62	Built-in humidifier: low steam production	-	-	Humidifier
A63	Built-in humidifier: water drain alarm	-	-	Humidifier
A64	Built-in humidifier: cylinder full alarm	-	-	Humidifier
A65	Built-in humidifier: cylinder being depleted signal	-	-	-
A66	Built-in humidifier: presence of foam	-	-	-
A67	Built-in humidifier: cylinder depleted	-	-	-

5.2 Alarm data logging

Alarms data logging allows storing the air-conditioning unit working state whenever an alarm goes off or under particular conditions. Any storing operation becomes an event, which can be displayed as any other event available in the memory. As it functions as a device for “taking photographs” of the system whenever any alarm goes off, data logging is extremely useful for suggesting possible causes and solving system malfunctions and failures. The program is provided with a MAIN and a DEVELOPED data logging.

5.3 Main log

Events can be stored thanks to the boards very large buffer memory. The MAIN data logging can be enabled by parameter; if the clock card (optional) is not available, neither the MAIN data logging is available. No additional optional card is required.

The maximum number of storable events is 100; after the last space available in the memory (alarm no. 100) is used, next alarm will be overwritten on the first alarm stored (001), which will be automatically deleted. This procedure applies to all following events. The user cannot delete the stored events except at the default values installation. The MAIN data logging screen can be accessed by pushing button ALARM when screen E4 is displayed and can be left by pushing button Esc. The screen is displayed as follows:

```
HISTORY_ALARMS
+-----+
|Alarms historic H025|
|Resistor 1 overload |
|12:34      01/08/01|
+-----+
```

Whenever an alarm goes off, the following air-conditioning unit data are stored for each alarm:

- alarm description
- time
- date
- event chronological number (0-100)

The event chronological number, displayed in the upper right corner, indicates the event “stay time” compared to the 100 available memory spaces. Alarm no. 001 represents the first alarm gone off after MAIN data logging enabling.

Moving the cursor on the chronological number and using the arrow buttons, the alarms “history” can be scrolled from 1 to 100.

In position 001 and pushing the down arrow, the alarms cannot be scrolled.

If, for example, 15 alarms have been stored and the cursor is in position 015, pushing the up arrow, the alarms cannot be scrolled.

6 SCREENS

The screens are divided into these categories:

MAINTENANCE: checking the devices periodically, calibrating the connected probes, modifying the working hours and managing the devices manually. PASSWORD = 105

PRINTER: printing the list of parameter only with a special version of display. NO PASSWORD

INPUT/OUTPUT: allow to show the digital and analog input/output values. NO PASSWORD

CLOCK: allow setting and enabling the temperature and humidity time bands. PASSWORD = 108

SETPOINT: allow setting the temperature and humidity set points and regulating the clock. NO PASSWORD

USER: allow setting the main functions (timing, sets, differentials) of the connected devices; PASSWORD = 108

MANUFACTURER: allow configuring the air-conditioning unit, enabling the main functions and selecting the connected device. PASSWORD = available on request. This menu is divided into these categories:

CONFIGURATION, PARAMETERS, CAREL EXV DRIVERS, TIMING AND INITIALIZATION.

6.1 List of the screens

The following list indicates the displayed screens. Columns represent the screens loops: the first screen (A0, B0...) can be displayed by pushing the relevant button and the other screens can be scrolled by using the arrow buttons. Codes (Ax, Bx, Cx...) are displayed in the screens upper right corner, so as to be easily identified. The meaning of symbols "0","1"... is explained in the previous paragraph. Symbol PSW indicates the screens for entering passwords.

MAIN	MAINTENANCE	PRINTER	INPUT/OUTPUT	CLOCK	SETPOINT	USER
M0	A0	H0	I0	K0	S0	PSW P0
M1	A1	H1	I1	PSW K1	S1	P1
M2	A2		I2	K2		P2
	A3		I3	K3		P3
	A4		I4	K4		P4
	A5		I5	K5		P5
	PSW A6		I6	K6		P6
	A7		I7	K7		P7
	A8		I8	K8		P8
	A9		I9	K9		P9
	Aa		Ia	Ka		Pa
	Ab		Ib			Pb
	Ac		Ic			Pc
	Ad		Id			Pd
	Ae		Ie			Pe
	Af		If			Pf
	Ag		Ig			Pg
	Ah		Ih			Ph
	Ai		Ii			Pi
	Aj		Ij			Pj
	Ak		Ik			
	Al		Il			
	Am		Im			
	An		In			
			Io			
			Ip			
			Iq			
			Ir			
			Is			
			It			
			Iu			
			Iv			

MANUFACTURER			
PSW	Z0	Gb	T5
	Z1	Gc	T6
CONFIGURATION →	C0	Gd	T7
	C1	Ge	T8
	C2	Gf	INITIALISATION → V0
	C3	Gg	V1
	C4	Gh	V2
	C5	Gi	
	C6	Gj	
	C7	Gk	
	C8	Gl	
	C9	Gm	
	Ca	Gn	
	Cb	Go	
	Cc	CAREL EXV DRIVER → F0	
	Cd	F1	
	Ce	F2	
	Cf	F3	
	Cg	F4	
	Cj	F5	
	Ci	F6	
	Cl	F7	
	Cm	F8	
	Cn	F9	
	Co	Fa	
	Cp	Fb	
	Co	Fc	
	Cp	Fd	
PARAMETERS →	G0	Fe	
	G1	Ff	
	G2	Fg	
	G3	Fh	
	G4	Fi	
	G5	Fj	
	G6	TIMING → T0	
	G7	T1	
	G8	T2	
	G9	T3	
	Ga	T4	

7 LIST OF PARAMETERS AND DEFAULT VALUES

The table below lists the parameters in the program, together with the following information: screen code (the screen code is displayed at the top right) to assist the identification of the parameter, the default value, the minimum and maximum limits (range), and the unit of measure.

To find a specific parameter on the display, proceed as follows:

- Identify the parameter in the table below and the corresponding screen code
- Using the list of the screens (following paragraph) and the screen code, access the screen on the display

PARAMETER DESCRIPTION	SCREEN	DEFAULT	SPECIAL VALUE	RANGE	UOM
Maintenance Menu					
Select display language	A0	English		En, It, Fr, De	
Enter password	A6	----		0-9999	
Modify outlet fan operating hours	A7	0		0-99 . 0-999	hours
Modify compressor 1 operating hours	A7	0		0-99 . 0-999	hours
Modify compressor 2 operating hours	A7	0		0-99 . 0-999	hours
Device operating hour threshold: main fan	A8	99		0-99	hours x 1000
Device operating hour threshold: compr. circuit 1	A8	99		0-99	hours x 1000
Device operating hour threshold: compr. circuit 2	A8	99		0-99	hours x 1000
Humidity probe calibration	A9	0		-9.9 – 9.9	%RH
Condenser 1 pressure probe calibration	A9	0		-99.9 – 99.9	bar
Condenser 2 pressure probe calibration	A9	0		-99.9 – 99.9	bar
Ambient temperature probe calibration	Aa	0		-99.9 – 99.9	°C / °F
External temperature probe calibration	Aa	0		-99.9 – 99.9	°C / °F
Supply temperature probe calibration	Aa	0		-99.9 – 99.9	°C / °F
Recovery temperature probe calibration	Ab	0		-99.9 – 99.9	°C / °F
Condenser 1 temperature probe calibration	Ab	0		-99.9 – 99.9	°C / °F
Condenser 2 temperature probe calibration	Ab	0		-99.9 – 99.9	°C / °F
Manual activation of digital outputs 1 – 2 – 3	Ac	Off		Off – On	
Manual activation of digital outputs 4 – 5 – 6	Ad	Off		Off – On	
Manual activation of digital outputs 7 – 8 – 9	Ae	Off		Off – On	
Manual activation of digital outputs 10 – 11 – 13	Af	Off		Off – On	
Manual activation of modulating outputs 1 – 2	Ag	0		0-10.0	Volt
Manual activation of modulating outputs 3 – 4	Ah	0		0-10.0	Volt
Manual activation of pre wash built-in humidifier	Ai	No		No-Yes	
Manual activation of total water drain built-in humidifier	Ai	No		No-Yes	
Hum. management: periodic drain enable	Ai1	No		No-Yes	
Hum. management: periodic drain period	Ai1	120		0-120	hours
Hum. management: stop delay	Ai2	0		0-120	seconds
Hum. management: drain for inactivity period	Ai2	3		1-199	hours
Hum. management: threshold running hours	Ai3	4000		0 - 4000	hours
Driver 1 valve control mode	Aj	Automatic		Auto-Man.	
Driver 1 valve manual opening steps	Aj	0		0-9999	Steps
Driver 2 valve control mode	Ak	Automatic		Auto-Man.	
Driver 2 valve manual opening steps	Ak	0		0-9999	Steps
Driver 1 manual release on start-up	Al	No		No-Yes	
Driver 2 manual release on start-up	Am	No		No-Yes	
Enter new Maintenance password	An	----		0-9999	
Printer Menu					
Cyclical print interval	H1	24		0-999	hours
Send immediate print	H1	No		No-Yes	
Clock Menu					
Hour setting	K0	current hour		0-23	hours
Minute setting	K0	current minutes		0-59	minutes
Day setting	K0	current day		1-31	
Month setting	K0	current month		1-12	
Year setting	K0	current year		0-99	
Enter Clock password	K1	----		0-9999	

PARAMETER DESCRIPTION	SCREEN	DEFAULT	SPECIAL VALUE	RANGE	UOM
Enable temperature / humidity / On-Off time bands	K2	No / No / No		No-Yes	
Start and end hour for On-Off time bands F1-1 and F1-2	K3	9 / 13 / 14 / 21		0-23	hours
Start and end minutes for On-Off time bands F1-1 and F1-2	K3	0 / 0 / 0 / 0		0-59	minutes
Start and end hour for On-Off time band F2	K4	14 / 21		0-23	hours
Start and end minutes for On-Off time band F2	K4	0 / 0		0-59	minutes
Select On-Off time bands (F1,F2,F3,F4) for each day	K5	F3		F1-F2-F3-F4	
Start hour temperature bands 1 and 2	K6	0 / 6		0-23	hours
Start minutes temperature bands 1 and 2	K6	0 / 0		0-59	minutes
Set point temperature bands 1 and 2	K6	23.0 / 23.0		see P1	°C / °F
Start hour temperature bands 3 and 4	K7	12 / 18		0-23	hours
Start minutes temperature bands 3 and 4	K7	0 / 0		0-59	minutes
Set point temperature bands 3 and 4	K7	23.0 / 23.0		see P1	°C / °F
Start hour humidity bands 1 and 2	K8	0 / 6		0-23	hours
Start minutes humidity bands 1 and 2	K8	0 / 0		0-59	minutes
Set point humidity bands 1 and 2	K8	50.0 / 50.0		see P2	%RH
Start hour humidity bands 3 and 4	K9	12 / 18		0-23	hours
Start minutes humidity bands 3 and 4	K9	0 / 0		0-59	minutes
Set point humidity bands 3 and 4	K9	50.0 / 50.0		see P2	%RH
Enter new Clock password	Ka	----			
Setpoint Menu					
Temperature set point	S1	23.0		see P1	°C / °F
Humidity set point	S1	50.0		see P2	%RH
User Menu					
Enter user password	P0	----		0-9999	
Minimum and maximum temperature set point limits	P1	-99.9 / 99.9		-999.9-999.9	°C / °F
Minimum and maximum humidity set point limits	P2	0.0 / 100.0		0.0-100.0	%RH
Proportional temperature bands (differential) in Heating and cooling	P3	3.0 / 3.0		0.0-100.0	°C / °F
Temperature dead zone (neutral zone)	P3	0,5		0.0-99.9	°C / °F
Proportional bands in Humidification and Dehumidification	P4	2.0 / 2.0		0.0-99.9	%RH
Maximum production allowed, built-in humidifier	P4	70.0		0% -100%	% kg/h
Show language screen at start-up	P5	No		No-Yes	
Switch unit off from button	P5	Yes		No-Yes	
Enable remote On-Off digital input	P5	Yes		No-Yes	
Recovery water temperature set point	P6	12,0		0-99.9	°C / °F
Recovery air temperature set point / Differential	P6	3.0 / 2.0		0-99.9	°C / °F
Enable compensation function	P7	No		No-Yes	
Outside air compensation set point	P7	25.0		-999.9-999.9	°C / °F
Outside air compensation differential band	P7	3.0		-999.9-999.9	°C / °F
Offset maximum of compensation of the set of temperature	P7	2.0		-999.9-999.9	°C / °F
High and low ambient temperature alarms offset respect the setpoint	P8	10.0 / 10.0		-999.9-999.9	°C / °F
High and low ambient humidity alarms offset respect the setpoint	P9	20.0 / 30.0		0-100,0	%RH
Enable outlet limit function	Pa	No		No-Yes	
Outlet air set point for the limitation function	Pa	15.0		-999.9-999.9	°C / °F
Outlet air differential for the limitation function	Pa	5.0		-999.9-999.9	°C / °F
Assign type of alarm Serious/Minor AL01-AL20	Pb	All N		N-Y	
Assign type of alarm Serious/Minor AL21-AL40	Pc	All N		N-Y	
Assign type of alarm Serious/Minor AL41-AL60	Pd	All N		N-Y	
Assign type of alarm Serious/Minor AL61-AL70	Pe	All N		N-Y	
Board identification number for supervisory network	Pf	1		0-200	
Board communication speed for supervisory network	Pf	1200		1200-19200	Baudrate
Serial communication protocol	Pf	Carel		Carel, Modbus, Lon, RS232, Gsm	
Telephone numbers entered on analogue modem	Pg	0		1-4	
Enter telephone numbers on analogue modem	Pg	0		0...9,#,*,.@,^	
Number of rings for GSM modem	Pg	0		0-9	
Password to write SMS text message	Pg	0		0-9999	
Destination GSM telephone number	Pg	0		0...9,#,*,.@,^	

PARAMETER DESCRIPTION	SCREEN	DEFAULT	SPECIAL VALUE	RANGE	UOM
Number of rings for analogue modem	Ph	0		0-9	
Password for supervisor remote connection	Ph	0		0-9999	
Type of analogue modem	Ph	Tone		Tone-Pulse	
Enter new user password	Pi	----		0-9999	
Manufacturer Menu					
Enter manufacturer password	Z0	----		0-9999	
CONFIGURATION -->					
Enable BMS	C0	No		No-Yes	
Enable printer	C0	No		No-Yes	
Select unit of measure for temperature probes and parameters	C0	°C		°C-°F	
Enable clock board	C0	No		No-Yes	
Type of unit	C1	ED		ED-CW	
Select refrigerant	C1	R407C		R22,R134a, R404a, R407C, R410A	
Number of compressors	C2	2		1-2	
Enable compressor capacity-control steps (unloaders)	C2	No		No-Yes	
Heating mode	C2	Heaters		Heaters-Battery	
Humber of heaters	C2	2		0-1-2-Binary	
Type of valve for heating battery	C2	0-10Volt		0-10V / 3 points	
Type of coil	C3	C/H		C/H-Cool	
Type of valve for the coil	C3	0-10Volt		0-10V/ 3 points	
Heating mode	C3	Heaters		Heaters-Battery 2	
Humber of heaters	C3	2		0-1-2-Binary	
Type of valve for heating coil	C3	0-10Volt		0-10V/3 points	
Digital input 5 configuration	C4	Filter alarm		Flood alarm, Filter alarm, Fire alarm	
Digital input 12 configuration	C5	Fire/smoke alarm		Fire/smoke alarm, Water Flood alarm	
Digital input 1 configuration	C6	Fire/smoke alarm		Fire/smoke alarm, Water Flood alarm	
Digital output 7 configuration	C7	Light alarm relay		Recovery valve, Light alarm relay	
Analog input 2 configuration	C8	Pressure circ. 1		Pressure circ.1, Temp. circ. 1, Supply air temp.	
Analog input 3 configuration	C9	Pressure circ. 2		Pressure circ.2, Temp. circ. 2, Recovery temp.	
Modulating output 1 configuration	Ca	Main fan damper		Recovery damper, Main fan damper	
Recovery type	Ca	Air		Air, Water	
Enable analog humidifier output	Ca	No		No-Yes	
Analog output 2 configuration	Cb	Recovery damper		Recovery damper, Humidif. damper	
Recovery damper enable	Cc	No		No-Yes	
Main fan damper presence	Cc	No		No-Yes	
Enable condensation function	Cd	No		No-Yes	
Type of condenser	Cd	Single		Single-Separat.	
Condensing output type	Cd	Inverter		Inverter-Steps	
Select number of condensing fans	Cd	1		1-2	
Maximum voltage threshold for Triac	Ce	92,0		0-100	%
Minimum voltage threshold for Triac	Ce	7,0		0-100	%
Duration of Triac impulse	Ce	2		0-10	m seconds
Logic of the dehumidification contact	Cf	NC		NO-NC	
Number of compressors enabled for dehumidification	Cf	0		0-2	
Enable cooling coil for dehumidification	Cf	No		No-Yes	
Enable built-in humidifier	Cf	No		No-Yes	
Type of humidifier	Cg	3 Kg/h 400V 3Ph		3 Kg/h / 8 Kg/g	
Maximum production	Cg	70.0		0-100.0	%
Humidifier board type	Cg	PCOUMID000		PCOUMID200-PCOUMID000	
Enable humidity probe	Ch	Yes		No-Yes	
Type of signal from the humidity probe	Ch	Current		0-1V, 0-10V, Current	

PARAMETER DESCRIPTION	SCREEN	DEFAULT	SPECIAL VALUE	RANGE	UOM
Minimum and maximum value measured by the humidity probe	Ch	0.0 / 100.0		0-100.0	%RH
Enable pressure probe 1	Ci	No		No-Yes	
Type of signal pressure probe 1	Ci	Current		0-1V, 0-10V, Current	
Minimum and maximum value pressure probe 1	Ci	0.0 / 30.0		-20.0 - 50.0	Bar
Enable pressure probe 2	Cj	No		No-Yes	
Type of signal pressure probe 2	Cj	Current		0-1V, 0-10V, Current	
Minimum and maximum value pressure probe 2	Cj	0.0 / 30.0		-20.0 - 50.0	Bar
Room temperature probe type	Ck	NTC		NTC-PT1000	
Enable supply air probe	Ck	Yes		No-Yes	
Supply air temperature probe type	Ck	NTC		NTC-PT1000	
Enable external temperature probe	Cl	No		No-Yes	
External temperature probe type	Cl	NTC		NTC-PT1000	
Enable recovery temperature probe	Cl	No		No-Yes	
Recovery temperature probe type	Cl	NTC		NTC-PT1000	
Enable condenser 1 temperature probe	Cm	No		No-Yes	
Condenser 1 temperature probe type	Cm	NTC		NTC-PT1000	
Enable condenser 2 temperature probe	Cm	No		No-Yes	
Condenser 2 temperature probe type	Cm	NTC		NTC-PT1000	
LAN unit configuration Unit 1 (U1)	Cn	Present/No rotat.		Present/Rotation Present/No rotat. Not present	
LAN unit configuration Unit 2-3 (U2-U3)	Cn	Not present		Present/Rotation Present/No rotat. Not present	
LAN unit configuration Unit 4-5-6 (U4-U5-U6)	Co	Not present		Present/Rotation Present/No rotat. Not present	
LAN unit configuration Unit 7-8 (U7-U8)	Cp	Not present		Present/Rotation Present/No rotat. Not present	
Enable analog fan on analog out 2	Cq	Yes		No-Yes	
Enable expansion card	Cr	Off		Off-On	
Enable expansion card alarm	Cr	Off		Off-On	
Expansion card alarm delay	Cr	120		0-999	seconds
Reheating system	Cs	No Reheating		No Reheating, Elect. Heaters, Hot gas On/Off, Hot gas modulat.	
PARAMETERS -->					
Enable compressors/cooling battery together with recovery valve	G0	No		No-Yes	
Enable FIFO compressor rotation	G1	Yes		No-Yes	
Temperature regulation type	G1	Prop.		Prop.-P+I	
Logic of the capacity-control contact	G1	NC		NC-NO	
Starting point to open modulating valve in cooling (or single valve) with recovery (see G0)	G2	50.0		0.0-100.0	%
Starting and end point to open modulating valve in cooling (or single valve)	G2	0.0 / 100.0		0.0-100.0	%
Starting point to open 3 position valve in cooling (or single valve) with recovery (see G0)	G3	50,0		0.0-100.0	%
Starting and end point to open 3 position valve in cooling (or single valve)	G3	0.0 / 100.0		0.0-100.0	%
Starting and end point to open modulating valve in heating	G4	0.0 / 100.0		0.0-100.0	%
Starting and end point to open 3 position valve in heating	G5	0.0 / 100.0		0.0-100.0	%
Starting and end point to open modulating valve in recovery	G6	0.0 / 100.0		0.0-100.0	%
Minimum and maximum main fan speed	G7	0.0 / 10.0		0.0-10.0	Volt
Main fan speed during dehumidification	G7	5.0		0.0-10.0	Volt
Starting and end point to open modulating humid. output	G8	0.0 / 10.0		0.0-10.0	Volt
Temperature differential to stop dehumidification	G9	5.0		0-99.9	°C / °F
Temperature offset to restart dehumidification	G9	4.0		0-99.9	°C / °F
Disable water drain for set point reduction	Ga	No		No-Yes	
Disable drain for extended humidifier standby	Ga	No		No-Yes	
Disable humidifier alarm messages	Ga	No		No-Yes	
High conductivity pre-alarm threshold	Gb	1500		0-2000	uS/cm

PARAMETER DESCRIPTION	SCREEN	DEFAULT	SPECIAL VALUE	RANGE	UOM
High conductivity alarm threshold	Gb	2000		0-2000	uS/cm
Drain time as % of the manufacturer value	Gc	100		50-200	%
Drain frequency as % of the manufacture value	Gc	100		50-200	%
High pressure alarm set point	Gd	23.5		-99.9 - 99.9	bar
High pressure alarm differential	Gd	1.0		-99.9 - 99.9	bar
Condensing (pressure) setpoint	Ge	19.0		-99.9 - 99.9	bar
Condensing (pressure) differential	Ge	4.0		-99.9 - 99.9	bar
Modulating condensing fan speed-up time	Ge	30		0-999	seconds
Condensing (temperature) setpoint	Gf	55.0		-99.9 - 99.9	°C / °F
Condensing (temperature) differential	Gf	1.0		-99.9 - 99.9	°C / °F
Modulating condensing fan speed-up time	Gf	30		0-999	seconds
Maximum and Minimum condensing fan speed	Gg	10.0 / 0.0		0-10.0	Volt
Enable high pressure alarm Prevent function	Gh	Yes		No-Yes	bar
Prevent function set point (pressure)	Gh	20.0		-99.9 - 99.9	bar
Prevent function differential (pressure)	Gh	2.0		-99.9 - 99.9	bar
Enable high temperature alarm Prevent function	Gi	Yes		No-Yes	bar
Prevent function set point (temperature)	Gi	70.0		-99.9 - 99.9	°C / °F
Prevent function differential (temperature)	Gi	1.0		-99.9 - 99.9	°C / °F
Enable Master Control function	Gj	No		No-Yes	
Rotation mode for units in pLAN network	Gk	Automatic		Automatic, Timezones, Running Hours	
Number of units set in Standby mode	Gk	0		0-Number of unit in Present/Rotat. mode	
Automatic rotation period for units in pLAN	Gk	24		1-240	Hours
Timezones rotation hour for units in pLAN network	Gl	22		0-23	Hours
Timezones rotation minutes for units in pLAN network	Gl	00		0-59	minutes
Interval in days for timezones rotation in pLAN network	Gl	3		1-7	days
Enable Force units by temperature in pLAN network	Gm	No		No-Yes	
Forcing delay for low and high ambient temperature	Gm	3 / 3		0-999	minutes
Low room temp. diff. for forcing units in network	Gn	8		0-99.9	°C / °F
Low room temp. offset for forcing units in network	Gn	4		0-99.9	°C / °F
High room temp. diff. for forcing units in network	Go	8		0-99.9	°C / °F
High room temp. offset for forcing units in network	Go	4		0-99.9	°C / °F
Analog supply fan speed setting	Gp	80		0-100%	%
CAREL EXV DRIVERS -->					
Number of drivers connected	F0	0		0-2	
Enable backup battery driver 1	F0	No		No-Yes	
Enable backup battery driver 2	F0	No		No-Yes	
Type of valve circuit 1	F1	10 (Carel E2V**P)		0-11	
Superheating set point circuit 1	F1	6.0		2.0-50.0	°C
Dead zone circuit 1	F1	0		0-9.9	°C
Type valve circuit 2	F2	10 (Carel E2V**P)		0-11	
Superheating set point circuit 2	F2	6.0		2.0-50.0	°C
Dead zone circuit 2	F2	0		0-9.9	°C
PID control – proportional gain circuit 1	F3	2.5		0.0-99.9	
PID control – integration time circuit 1	F3	30		0-999	seconds
PID control – derivative time circuit 1	F3	5.0		0.0-99.9	seconds
PID control – proportional gain circuit 2	F4	2.5		0.0-99.9	
PID control – integration time circuit 2	F4	30		0-999	seconds
PID control – derivative time circuit 2	F4	5.0		0.0-99.9	seconds
Threshold for low superheat protection circuit 1	F5	4.0		-4.0 - 10.0	°C
Prot. threshold integration time, low superheat circuit 1	F5	1.0		0-25.5	seconds
Threshold for low superheat protection circuit 2	F6	4.0		-4.0 - 10.0	°C
Prot. threshold integration time, low superheat circuit 2	F6	1.0		0-25.5	seconds
Percentage ratio between cooling capacity and Driver capacity C 1	F7	30		0-100	%
Percentage ratio between cooling capacity and Driver capacity C 2	F7	30		0-100	%
LOP threshold	F8	-40.0		-70.0 - 50.0	°C
LOP threshold integration time	F8	4.0		0-25.5	seconds
MOP start delay	F9	30		0-500	seconds
MOP threshold	F9	16.0		-50.0 - 99.9	°C

PARAMETER DESCRIPTION	SCREEN	DEFAULT	SPECIAL VALUE	RANGE	UOM
MOP threshold integration time	F9	4.0		0-25.5	seconds
High condensing temp. protection threshold	Fa	63.0		0-99.9	°C
Integration time for high condensing temp. threshold	Fa	4.0		0-25.5	seconds
High suction temperature threshold	Fb	30.0		0-100.0	°C
Custom Valve: minimum steps	Fc	0		0-8100	
Custom Valve: maximum steps	Fc	1600		0-8100	
Custom Valve: closing steps	Fd	3600		0-8100	
Custom Valve: return steps	Fd	0		0-8100	
Custom Valve: enable extra step in opening	Fe	No		No-Yes	
Custom Valve: enable extra step in closing	Fe	No		No-Yes	
Custom Valve: operating current	Ff	250		0-1000	mA
Custom Valve: holding current	Ff	100		0-1000	mA
Custom Valve: frequency	Fg	100		32-330	Hertz
Custom Valve: duty cycle	Fg	50		0-100	%
Minimum evaporation pressure probe value	Fh	0.0		-9.9 - 10.0	Bar
Maximum evaporation pressure probe value	Fh	30.0		3.5 - 40.0	Bar
Low superheating alarm delay	Fi	0		0-3600	seconds
High suction temperature alarm delay	Fi	0		0-3600	seconds
LOP alarm delay	Fj	0		0-3600	seconds
MOP alarm delay	Fj	0		0-3600	seconds
TIMES -->					
Supply fan start and stop delay	T0	10 / 20		0-999	seconds
Integration time for P+I temperature control	T1	600		0-999	seconds
Travel time for 3 position valve	T1	180		0-999	seconds
Low pressure alarm delay	T2	180		0-9999	seconds
High-low temperature-humidity alarm delays	T2	600		0-9999	seconds
Not serious alarm activation delay	T3	0		0-9999	seconds
Serious alarm activation delay	T3	0		0-9999	seconds
Air flow switch alarm delay	T4	10		0-9999	seconds
Water flow switch alarm delay	T4	10		0-9999	seconds
Minimum compressor off time	T5	180		0-9999	seconds
Minimum compressor on time	T5	60		0-9999	seconds
Delay between compressor starts	T6	360		0-9999	seconds
Minimum delay between starts of different compressors	T6	10		0-999	seconds
Cap. control activation delay	T7	10		0-9999	seconds
Start delay between comps. of same circuit	T7a	30		0-999	seconds
Stop delay between comps. of same circuit	T7b	30		0-999	seconds
Heater start delay	T8	3		0-9999	seconds
INITIALISATION -->					
Enter password for reset Default values function	V0	----		0-9999	
Delete BASIC alarm log	V1	No		No-Yes	
Enter new manufacturer password	V2	----		0-9999	

8 ARCHITECTURE OF THE CONTROL SYSTEM

8.1 Microprocessor layout

Connector description

1. connector to the power supply [G(+), G0(-)];
2. fuse 250 Vac, 2A delayed (T2 A);
3. universal analog inputs NTC, 0/1 V, 0/5 V, 0/20 mA, 4/20 mA;
4. passive analog inputs NTC and ON/OFF;
5. passive analog inputs NTC;
6. Yellow LED indicating power supply on and 3 indicator LEDs;
7. 0/10 V analogue outputs and PWM phase-cut outputs;
8. digital inputs at 24 Vac/Vdc;
9. digital inputs at 230 Vac or 24 Vac/Vdc;
10. connector with Vref for 5V power supply to probes and V Term for power supply to display;
11. connector for all standard displays in the pCO series and for downloading the application program;
12. pLAN local network connector;
13. connector for connection to the programming key;
14. digital outputs to relay;
15. flap for selection of analog input type;
16. flap for installation of serial board:
 - RS485 for supervisor (optional)
 - Gateway (protocol converter, optional)
17. flap for installation of clock board (optional).

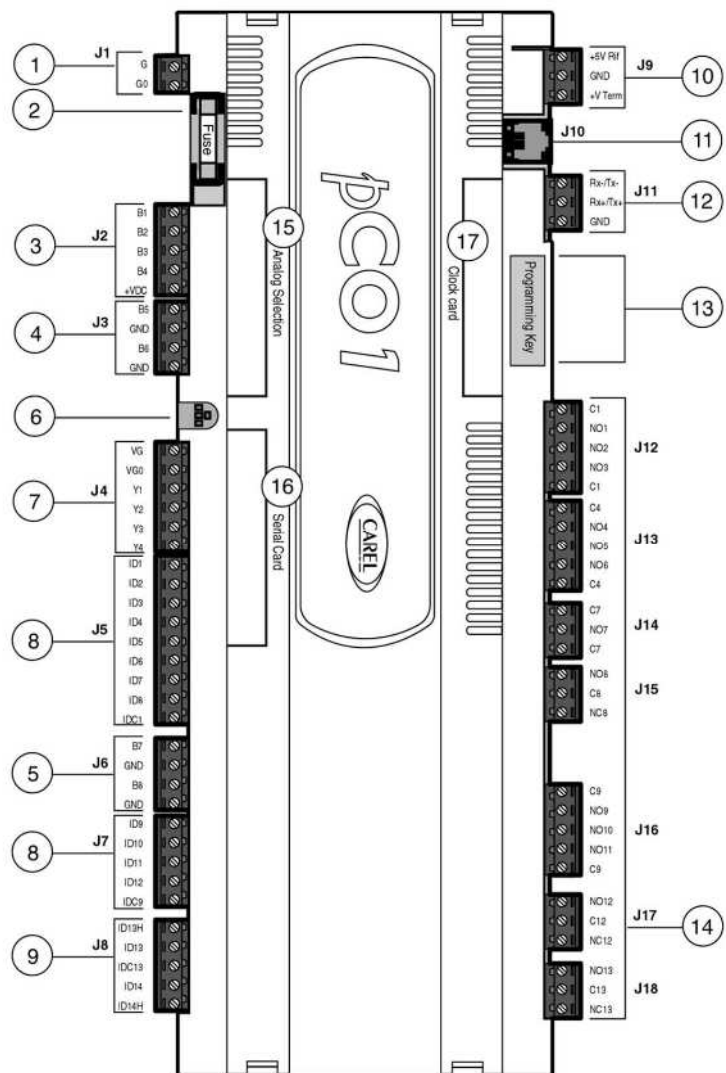

Figure 15: Layout microprocessore

8.2 Configuration list

The pCO1 boards allow managing both “DX” direct expansion and “CW” water coil air-conditioning units. When started, the program recognises the board type and size, consequently prearranging inputs and outputs, also based on the air-conditioning unit type (DX or CW) established in the Manufacturer branch.

Note:

For the input/output configuration see the electrical diagram.

8.3 Accessories

8.3.1 Electronic expansion valve

The EVDriver module for the control of the electronic expansion valves (EEV) for LAN network allows the inlet overheating control for amore efficient and versatile operation of the refrigerating unit.

Efficient because the optimisation and the stabilization of the refrigerant flow to the evaporator increase the performance of the installation assuring at the same time the safety (less activations of the low pressure switch, less backflows of the refrigerant to the compressor,...).

Moreover, if the EEV has been properly dimensioned, using the floating or low setpoint condensation (and evaporation) pressure increase remarkably the efficiency of the installation allowing less energy consumption and a better refrigerating yield.

Versatile because using the electronic expansion valve implies the possibility to manage refrigerating units with very different capacities and in different operating conditions.

The use of the electronic expansion valve implies the installation not only of the EVDriver or the expansion valve themselves, but also of a temperature sensor and a pressure transducer, both of them placed at the end of the evaporator on the refrigerant side (on the compressor inlet pipe). Refer to the following diagram for a better understanding of the typical installation layout.

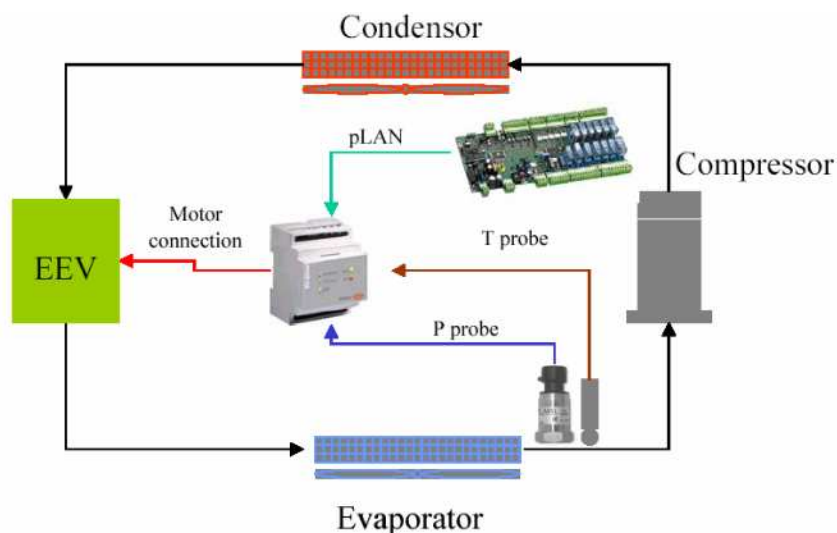

The base principle of the new control algorithm aims at the installation stability combined with, when possible, a quick achievement of the overheating steady state.

In this sense, the priorities to be considered for an optimum control of the refrigerating installation are a high and constant refrigerating yield rather than an extremely low and stable overheating.

The heart of the control is a PID controller that features coefficients that can be set for the overheating.

The additional controls are:

- LOW (Low overheating with integral time and adjustable threshold)
- LOP (Low evaporation pressure, operating actually only on transients, with integral time and adjustable threshold)

- MOP (High evaporation pressure, with integral time and adjustable threshold)
- HiTcond (High condensation pressure that can be activated only by condensation pressure probe read by pCO, with integral time and adjustable threshold).

In the parameter table, the control parameters, with the thresholds and the default values, are described.

8.3.2 Accessories

SERIAL CARDS

The Rs485 serial card allows interfacing pCO1 boards directly to a Rs485 network. The maximum available baud-rate corresponds to 19,200 (programmable by parameter). Connection with Rs485 network is executed by connecting the extractible connector to the board displays. As for connections, refer to the instruction sheet.

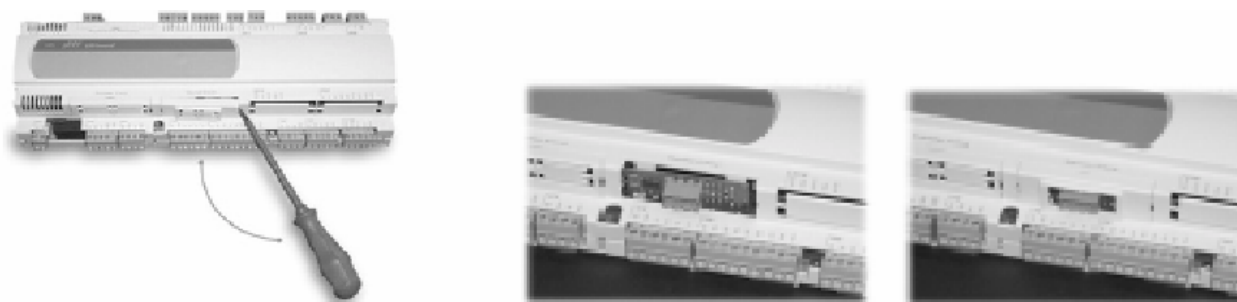

CLOCK CARD FOR pCO1

The clock option card allows managing the hour and date (day, month, year) for functions such as the time bands. The clock card shall be inserted by removing the relevant port placed on its connector.



PCO200KEY0 HARDWARE KEY FOR pCO1

The hardware key allows downloading the application program to the pCO1 board in the place of the computer; furthermore, it also allows uploading the Flash memory contents to the key.

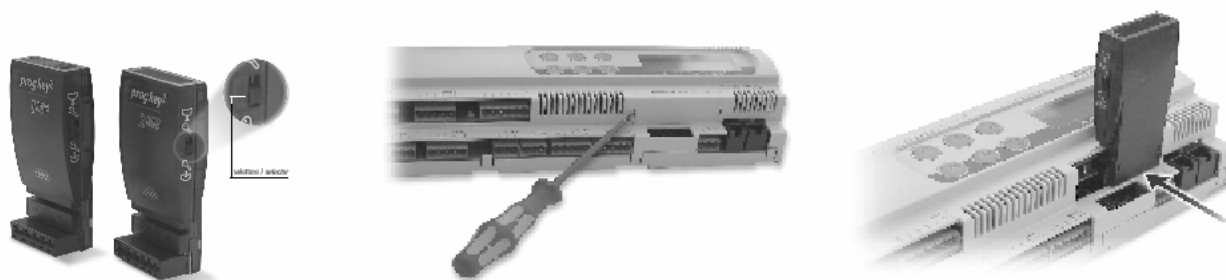

8.3.3 Built-in humidifier

Integrated management of a Carel immersed electrode humidifier. The pCO1 boards manage all the functions, from the reading of the humidifier parameters to the control of the devices (fill, drain, output) by relay. The humidifier parameters (current, conductivity, level) are not read directly, but rather using an electronic card. The LCD display features screens for controlling the humidifier. The program controls the steam output and the humidifier operating conditions based on the humidifier current and ambient humidity signals; furthermore, it manages and displays all states and alarms.

9 SUPERVISION

pCO1 can be connected with a local or remote supervisory PC, a GSM or traditional modem and the most spread BMS (Modbus, Bacnet, Lonworks). To be used, the listed functions require the installation of optional cards (Rs485, Rs232, LON) or Gateways (devices able to interpret different communication protocols).

9.1 Supervisor and bms

Advanced Control pCO - Local Area Network

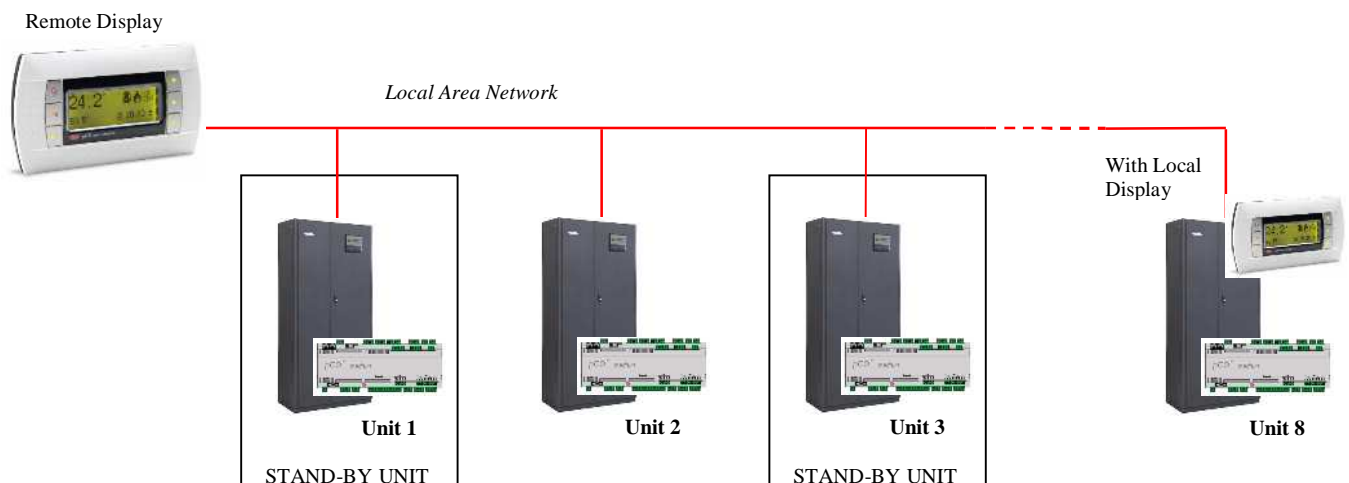

Max. number of units: 8

Description:

- Master / Slave function:

the "master" unit temperature and humidity probes must be located in an "intermediate" position inside the controlled environment. The "master" unit drives the logic to be adopted from all connected units. That's important to avoid situations like units in dehumidification and units in humidification at the same time and in the same environment. The "Master" unit modifies the working logic in case the measured temperature or humidity exceed the set point, even by few decimal points. In case of black-out or "master" unit disconnection from LAN network, the connected units start functioning independently based on the their own probes only.

- Stand-by rotation activated by timing, time band or automatic on event.

- Stand-by rotation of 1 to N-1 unit (where N is the number of installed unit)

HiNet supervising systems

It allows air-conditioning systems to be monitored and controlled using a simple

Internet browser: the pages displayed on the PC are in HTML format, the language of the worldwide web.

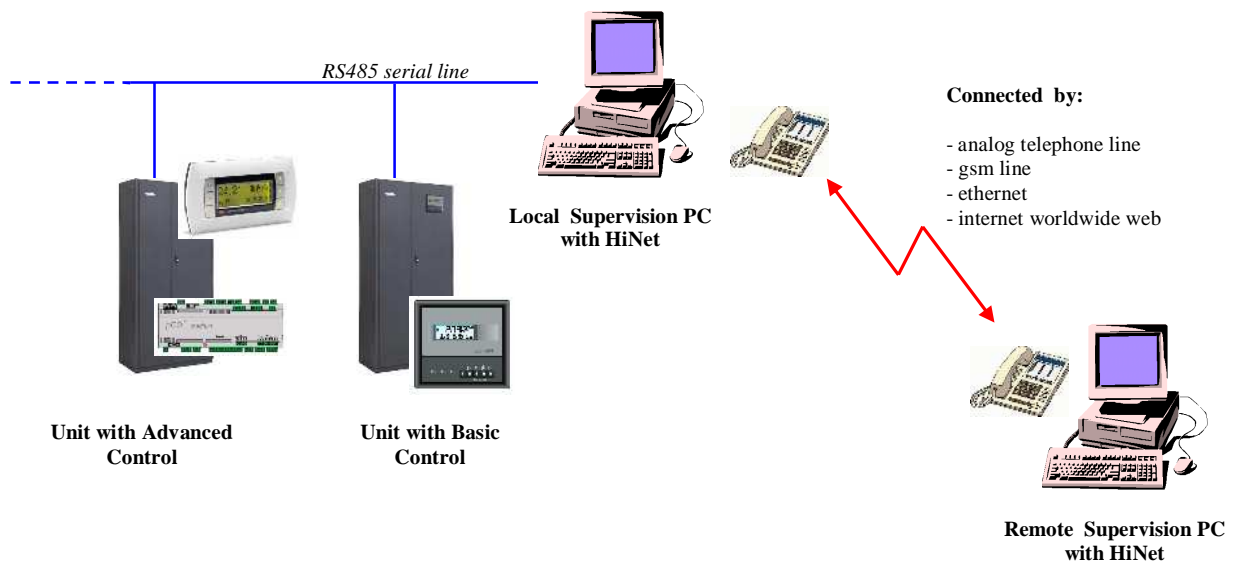

BMS integration

DATAACCOL units can be connected to the BMS in the following ways:

- directly, without using a gateway, thanks to the ability of the advanced control pCO to select the protocol used;
- using a gateway that converts the Carel proprietary protocol to the protocol used by the BMS;
- integrating the driver for the management of the Carel proprietary protocol into the BMS.

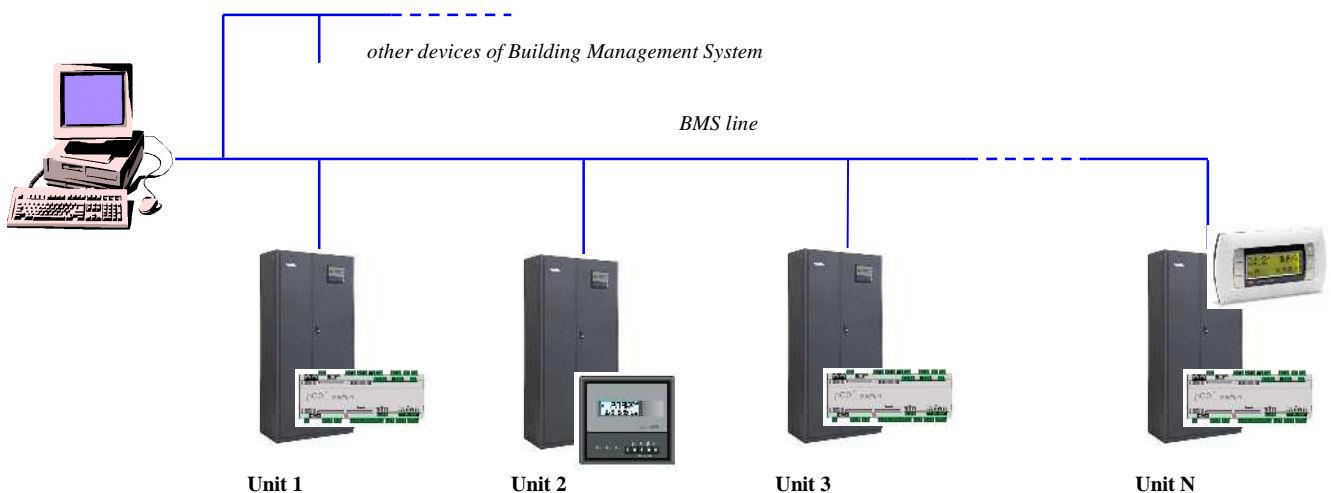

The following protocols are used to ensure connectivity to the other systems:

- Carel proprietary (with HiNet supervision system, N = 200)
- Modbus (with gateway for Basic Control, N = 16; integrated for Advanced Control, N =)
- Bacnet (with gateway, N = 8)
- TCP/IP (with web-gate, N = 16)
- Echelon LonWorks (only with Advanced Control)
- Trend (only with Advanced Control)
- OPC standard (OLE for Process Control). This allows a simple integration to SCADA OPC Client Systems.
[SCADA =Supervisory Control And Data Acquisition]

9.2 Gsm protocol

By selecting the GSM protocol, SMS (text) messages can be sent to and from GSM phones, using a GSM modem. The pCO1 sends a message to the phone in the event of alarms, and can receive messages from the telephone at any time; the user can in fact use a GSM phone to modify some of the unit's parameters, as listed below:

Parameter	Unit Add. 1	Unit Add. 2	Unit Add. 3	Unit Add. 4	Unit Add. 5	Unit Add. 6	Unit Add. 7	Unit Add. 8
Temperature set point	analogue 1	analogue 10	analogue 19	analogue 28	analogue 37	analogue 46	analogue 55	analogue 64
Humidity set point	analogue 2	analogue 11	analogue 20	analogue 29	analogue 38	analogue 47	analogue 56	analogue 65
2Recovery set point	analogue 3	analogue 12	analogue 21	analogue 30	analogue 39	analogue 48	analogue 57	analogue 66
Compensation set point	analogue 4	analogue 13	analogue 22	analogue 31	analogue 40	analogue 49	analogue 58	analogue 67
Low temperature alarm threshold offset	analogue 5	analogue 14	analogue 23	analogue 32	analogue 41	analogue 50	analogue 59	analogue 68
High temperature alarm threshold offset	analogue 6	analogue 15	analogue 24	analogue 33	analogue 42	analogue 51	analogue 60	analogue 69
Low humidity alarm threshold offset	analogue 7	analogue 16	analogue 25	analogue 34	analogue 43	analogue 52	analogue 61	analogue 70
High humidity threshold offset	analogue 8	analogue 17	analogue 26	analogue 35	analogue 44	analogue 53	analogue 62	analogue 71
Outlet air limit set point	analogue 9	analogue 18	analogue 27	analogue 36	analogue 45	analogue 54	analogue 63	analogue 72
Unit On-off	digital 1	digital 2	digital 3	digital 4	digital 5	digital 6	digital 7	digital 8

N.B. When the GSM protocol is active, the remote supervisor cannot call the pCO1 board.

9.3 Examples of installation

The connection of pCO1 boards in LAN network allows for the following functions:

1. balancing air-conditioning units working hours by spare units (in stand-by mode) rotation.
2. spare units start-up in case other units stop due to serious alarms or black-out.
3. spare units start-up to compensate for the excessive thermal load.
4. controlling up to 8 air-conditioning units by a single external LCD display.
5. operation of all air-conditioning units according to Master air-conditioning unit probes to adjust units operation.
6. managing alarms printing and probes values by shared external display.

Connection in LAN network allows configuring a wide range of systems. The following list includes the main system types to be possibly created, in order of complexity, and provides suggestions for executing connections:

1. one or more independent air-conditioning units (board(s) with LAN address 1 + external display(s), if any, with LAN address 25);
2. two or more air-conditioning units and one external display (boards with LAN addresses 1-8 connected with Rs485 via J11, display with LAN address 32 connected with one of the boards); this connection allows for the functions listed in the previous paragraph;
3. two or more air-conditioning units in LAN network, each provided with private display (boards with LAN addresses 1-8 connected with Rs485 via J11, displays with LAN addresses 25-32 connected with the relevant board); this connection allows for the functions listed in the previous paragraph.

Networks in which boards are connected with the LAN allow selecting the units involved in the Rotation functions, thus obtaining a mixed network with interacting and independent units.

LAN connection among the boards allows using a shared external display (add. 32) in addition to the boards private displays; this solution is adopted where private displays are assembled on the air-conditioning units and the shared display is installed inside a room.

IMPORTANT: if only one board is being used, it must have LAN address 1; no LAN electric connection is required and the external display, if any, must have LAN address 25.

9.4 Shared external display

The Menu main screen shows the LAN address of the displayed board in the upper right corner; in private displays, it is a fixed number corresponding to the LAN address of the board they are connected with (1-8).

Display no. 32 allows selecting the board to be displayed by pushing button Info; whenever a button is pressed, the address displayed in the upper right corner increases by 1 and the display shows the parameters of the board selected among the connected ones.

In case of a board alarm, the shared display automatically connects with it to display the alarm.

The shared display can be connected to any network board; in case of boards equipped with built-in display, the shared display must be connected to connector J10 by a telephone cable; in case of boards equipped with private external display, shown in the following figure, is required (private=Term n; shared=Term n+1):

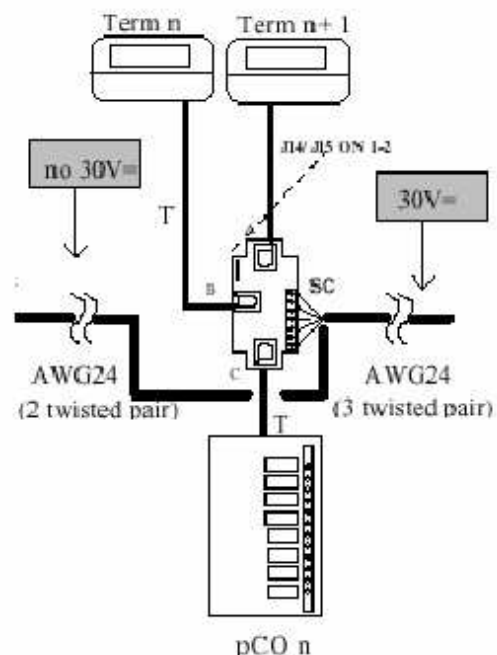

The shared display only allows printing all boards alarms and parameters.

9.5 Automatic start and stand-by units

The boards connected with LAN network may be managed directly by the program under “critical situations”, that is in case of failure (alarms, black-out...) or due to “Rotation” and “Forcing” functions.

The program acts based on some parameters that can be displayed and modified on the board with LAN address 1:

- Boards mode operation: Not present, Present/No Rotation, Present/Rotation. These are 8 parameters, one for each board. Not present: unit not connected. Present/No Rotation: unit physically connected with LAN network but not involved in the rotation function (however, unit can manage the shared display, printing and Master Control function). Present/Rotation: unit involved in Rotation too.
- Number of units in stand-by mode: this parameter establishes the number of units, among the ones selected in Present/Rotation mode, that must be set to stand-by mode (turned off, waiting for enabling) when starting the unit by button. The parameter is automatically included between 0 and the total number of Present/Rotation units minus one, to ensure start-up of at least one unit.

IMPORTANT. The following functions cannot be executed if:

- at least two units selected in Present/controlled mode are not present
- the stand-by units set number is 0

The board with LAN address 1 provides for functions management; if the board is disconnected from LAN network or it shuts down due to a black-out, the stand-by boards enable and the functions will be suspended until unit 1 is reset. On the contrary, unit 1 stop by On-off or remote On-off button does not interrupt network functions execution.

9.5.1 Critical situations

Units in Present/Rotation and stand-by modes are enabled in any of the following critical situations concerning the running boards:

- one of the boards has power cut off (black-out).
- one of the boards signals a Serious alarm that enables alarm relay no. 8 (each alarm can be programmed as serious or non-serious).
- one of the boards disconnects from LAN network due to Rs485 line disconnection.
- one of the boards is shut down by button or remote On-off digital input.
- one of the boards is shut down due to a serious alarm (refer to alarms table).

In case a running unit is involved in any of the listed situations, a stand-by board is automatically enabled to reset the number of running units. If, for example, two running units break or disconnect, the program enables two stand-by units; when one of the units under critical situation resets, it is started again and the spare unit returns to stand-by mode. If a critical situation involves the stand-by units, no LAN action occurs, with the exception of alarm signalling on the involved unit.

9.5.2 Forcing

Units in Present/Rotation and stand-by modes are enabled automatically in case a running unit does not reach the temperature set point for a certain time interval due to an excessive thermal load. Each unit running in such a situation can require enabling of a stand-by unit. The parameters to be set for forcing are Differential, Offset and Delay time, different for heating and cooling. The following diagram shows the forcing function:

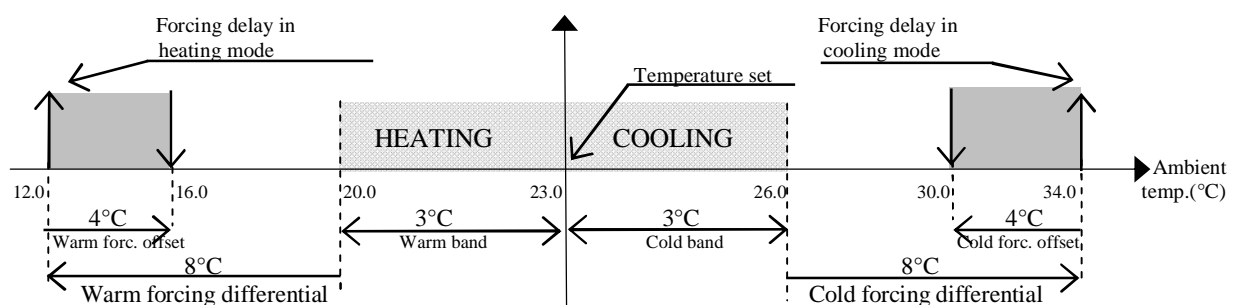

9.5.3 Fixed-hour rotation

A system consisting of both running and stand-by units is subject to unbalance in the working hours, causing running units to age faster than stand-by ones. To obviate this problem, LAN network can provide for units rotation, favouring balancing in the working hours. In practice, rotation sets a running unit to stand-by mode and starts a stand-by unit.

The fixed-hour rotation is based on a parameter establishing the rotations time interval. The programmable minimum time is 0h; in this case, automatic rotation enables every 5 minutes as a test. The maximum time is 240h (10 days). Time is counted from start-up of the unit with LAN address 1 that manages rotation. Rotation can be executed following the LAN addresses logic or the units working hours.

Selecting the addresses logic, the unit with highest address (among the running ones) switches from on to stand-by mode, whereas the unit with lowest address switches from stand-by mode to on.

Selecting the working hours logic, the unit with highest working hours (among the running ones) switches from on to stand-by mode, whereas the unit with lowest working hours switches from stand-by mode to on.

9.5.4 Fixed-day rotation

The clock card (optional) allows setting the hour and the days interval (max. 7) for units rotation. Logic is the same as the fixed-hour rotation, but in this case the rotation interval can be programmed for a determined day and hour.

9.5.5 Rotation based on working hours

This type of rotation involves the units with highest and lowest working hours, switching the former to stand-by mode and the latter to On mode. The reference working hours for this type of rotation are the same as the outlet fan ones; due to practical reasons, they can be modified in screens E6 and E7 of branch Maintenance.

9.6 *Master control*

The units connected with LAN network and in Present/... mode follow the working logic of the unit with LAN address 1, functioning as a "driver" unit so that the system can work with the same logic. This precaution prevents units from having opposite logic, something that may occur in wide environments with different temperatures or humidity areas. In such environments, each unit could follow the indications of the relevant probe, causing the uncontrolled start of humidification, dehumidification, heating or cooling. This would nullify their effect and cause energy waste.

WARNING: the "driver" unit temperature and humidity probes must be located in an "intermediate" position inside the controlled environment.

The "driver" unit sends the information concerning the logic to be adopted to the LAN network. Therefore, the network units found devices enabling on both reading of the relevant probes and "driver" unit order, so that devices can turn on in case the two factors coincide.

The "driver" unit modifies the working logic in case the measured temperature or humidity exceed the set point, even by few decimal points.

In case of black-out or "driver" unit disconnection from LAN network, the network units start functioning independently again based on the relevant probes only.

9.7 Technical data

General specifications

operating conditions	-10T60 °C 90% R H not condensing
protection rating	IP20, IP40 on front panel only
heat and fire resistance class	class D (UL94 - V0)
Immunity against over voltages	Class 1
number of manoeuvring cycles of automatic operations (e.g.: relay)	100 000
Class and structure of software	Class A

Electrical specifications

power supply (controller with connected display)	22 to 38 Vdc and 24 Vac \pm 15% 50/60 Hz. Maximum power consumption: 13 W
terminal block	with extractable male/female connectors maximum voltage: 250 Vac; cable size (2mm): min 0.5 to max 2,5
CPU	H8S2322 16 bits 14 MHz
program memory (on FLASH MEMORY)	16 bit organisation: 1 MByte (expandable to 2 MByte)
data memory (static RAM)	8 bit organisation: 128 kByte (expandable to 512 MByte)
Serial Board	16 bits organisation 4 kByte (upper limit: 400,000 recordings per memory location)
useful pCO1 cycle with applications of medium complexity	0.5 s

Analog inputs

number	8
Analog conversion	A/D converter 10 bit CPU built-in
type	<i>Passive:</i> NTC (inputs B5, B6, B7, B8) or clean contact digital input (5mA), selectable via dip-switch (B5-B6) <i>Universal:</i> NTC (see passive type), voltage 0 to 1 Vdc or 0 to 5 Vdc, current 0 to 20 mA or 4 to 20 mA, selectable via dip-switch (B1, B2, B3, B4)

Digital inputs

number	14
type	- optoisolated inputs at 24 Vac 50/60 Hz or 24 Vdc (ID1 to ID12) - optoisolated inputs at 24 Vac 50/60 Hz or 230 Vac (ID13 to ID14)

Analog outputs

number	4
type	- optoisolated 0 to 10 Vdc outputs (Y1 and Y2) - optoisolated PWM outputs phase-cut with 5 V pulse (Y3 and Y4)
power supply	external power supply 24 Vac/Vdc
output resolution	8 bit
maximum load	1k Ω (10 mA) at 0 to 10V and 470 Ω (10 mA) at PWM

Digital outputs

number	13
Type	-with electromechanical relays



www.lennox europe.com

BELGIUM, LUXEMBOURG
www.lennoxbelgium.com

CZECH REPUBLIC
www.lennox czech.com

FRANCE
www.lennoxfrance.com

GERMANY
www.lennox deutschland.com

NETHERLANDS
www.lennox nederland.com

POLAND
www.lennox polska.com

PORTUGAL
www.lennoxportugal.com

RUSSIA
www.lennoxrussia.com

SLOVAKIA
www.lennox distribution.com

SPAIN
www.lennoxspain.com

UKRAINE
www.lennoxukraine.com

UNITED KINGDOM AND IRELAND
www.lennoxuk.com

OTHER COUNTRIES
www.lennox distribution.com

Due to Lennox's ongoing commitment to quality, the Specifications, Ratings and Dimensions are subject to change without notice and without incurring liability.

Improper installation, adjustment, alteration, service or maintenance can cause property damage or personal injury.

Installation and service must be performed by a qualified installer and servicing agency.



INNOV@-PCO-IOM-0907-E