

Application guide



INNOV@

DX 20 - 120 kW

CW 30 - 236 kW

DH_R EC PLUG FAN

CLOSE CONTROL UNIT



Index

1	General Description	2
1.1	Structure.....	4
1.2	Application limits.....	4
1.3	Cooling circuit.....	5
1.4	Installation warnings	8
2	Inspection / Transport / Positioning	9
2.1	Inspection on receipt.....	9
2.2	Lifting and transport.....	9
2.3	Unpacking	9
2.4	Positioning.....	9
3	Installation	12
4	Evacuation and Charging Operations	14
4.1	Introductions.....	14
4.2	Full vacuum and charge of the unit	14
4.3	Evacuating a circuit “contaminated” with refrigerant	15
4.4	Charging positions (single point).....	15
5	Electrical Connections	16
5.1	Generalities.....	16
6	Operating Diagrams	17
7	Start-Up	18
7.1	Preliminary checks	18
7.2	Starting operations	18
7.3	Checks during operations	19
7.4	Checking the refrigerant charge (DX versions)	19
8	Setting Operating Parameters	20
8.1	Generalities	20
8.2	Maximum pressure switch.....	20
8.3	Minimum pressure switch	20
9	Maintenance	21
9.1	Warnings.....	21
9.2	Generalities	21
9.3	Set the right fan speed.....	23
9.4	EC fans	24
10	Troubleshooting	26
11	Technical Data	27

Codification

This codification describe the whole **INNOV@** range. All operating modes are not available on each type of unit.

Type of unit

DM	Medium range height 1875mm
DH	High range height 1998mm
IN	ENERGY range : eDrive unit with EC plug fan and BLDC compressor

Operating mode

A	:	Direct expansion with remote condenser
W	:	Direct expansion water condensed with remote dry-cooler
Z	:	Direct expansion city water condensed
F	:	Direct expansion water condensed with remote dry-cooler and indirect Free-cooling
C	:	Chilled water unit

Dual cooling units

In this case this is combination of unit with operating mode above and chilled water to work with chiller. Which provide more safety to your installation.

D	:	Direct expansion with remote condenser + chilled water coil
K	:	Direct expansion water condensed with remote dry-cooler + chilled water coil
Q	:	Direct expansion city water condensed + chilled water coil

Airflow configuration

U	:	Upflow
D	:	Downflow
X	:	Displacement

Type of fan

C	:	Centrifugal double inlet forward curve
R	:	EC plug fan

Nominal capacity

Capacity in kW (in this case 11kW)

DMAUR0110

Refrigerant circuit

0	:	1 or No compressor (CW)
2	:	2 compressors / 2 circuits
4	:	4 compressors / 2 circuits
5	:	1 compressor / 1 circuit

1 General Description

INNOV@ “CCAC” self-contained units are specially designed for installation in technological environments such as Computer rooms, laboratories and in general where a high precision in climate control and a 24h/day operation are requested. **INNOV@** units represent the state of the art between technology and design as well as all **LENNOX** products: thanks to their characteristics, **INNOV@** can be installed also in offices where people are working. The depth of 795 mm (950 mm for frame 4 and 5), allows the compatibility with standard electronic devices: furthermore the innovative design and the high tech selected colours make **INNOV@** units complementary to the last generation of IT devices. The internal design of the units in firstly made looking to efficiency and reliability but don't losing accessibility: all components, including e-heaters, fans, compressors, valves, etc. can be maintained from the front and furthermore the door(s) are dismountable in few seconds thanks to an innovative hinge: this is very important when units are installed in small corridors. The exclusive use of primary brands components and a fully integrated development process (CAD + CAM, CAE) stands for highest possible quality level regarding efficiency, reliability, maintenance time, pre and after sales support.

Fig. 1 Versions: DX / CW

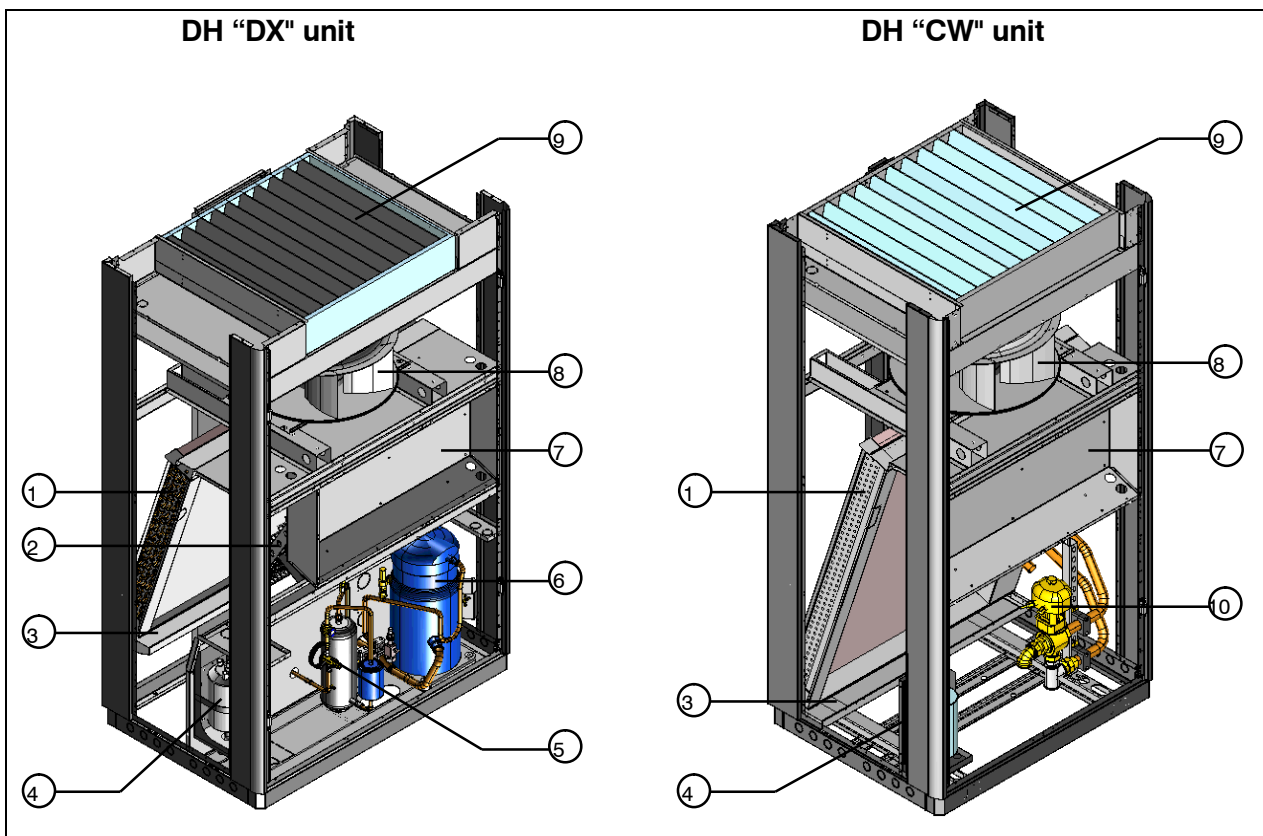

Pos.	Description	Pos.	Description
1	Chilled water coil (CW), evaporating coil (DX)	6	Compressor (Scroll)
2	Electrical heaters	7	Electrical panel
3	Steinless steel drain pan	8	Fan
4	Humidifier	9	Air filter
5	Thermostatic valve	10	Water valve

1.1 Structure

INNOV@ units are designed with a self supporting frame and all components are produced using sophisticated computer driven machines and special tools. All sheet metals are galvanized and all external panels are powder coated RAL 9002 giving to the units the image and the quality like last generation of IT devices. Units are completely closed and only frontal access is requested. Anyway it is also possible to have side access in order to reach the steam piping and the drain pan, or simply to substitute a damaged side panel: all this problems are very rare, but with **INNOV@** units it is possible to solve them. The shape of the units is characterized with the curved edges with variable radius: this feature is obtained using special tools and gives both a good aesthetic and advantages against injuries. The compressor compartment is separated from the air flow and the special internal design allows the simple dismounting of the upper part of it ensuring an insuperable accessibility to all refrigerating components.

All fixing elements are made in stainless steel or in non corroding materials. The dray pan is made in stainless steel in order to ensure long time operation without damages.

All panels are thermally insulated with a polyurethane foam class 1 according UL 94 norms: this material, thanks to the open cells, gives good performances in sound absorption. As an option, sandwich panels are available: in this case mineral fibres are closed between the panel and a second sheet of metal giving the maximum in terms of internal cleaning. Double skin panels are classified between non flammable materials class A1 according DIN 4102 norms : the sound insulation is better than the standard solution, but the internal reflected sound power will increase the amount in delivery side (+2dB).

1.2 Application limits

Tab. 1 Operation limits "DX"

Power supply limits and storage conditions for "DX" version

Model	INNOV@ DHA . . . R	
Power supply	400 / 3+N / 50 +/-10 %	
Storage conditions	from	-10 °C / 90 % R.H.
	to	+55 °C / 90 % R.H.

Tab. 2 Operation limits "CW"

Power supply limits and storage conditions for "CW" version

Model	INNOV@ DHC . . . R	
Power supply	400 / 3+N / 50 +/-10 %	
Storage conditions	from	-10 °C / 90 % R.H.
	to	+60 °C / 90 % R.H.

Fig. 2 Application limits (DX unit with stadard condenser in catalog)

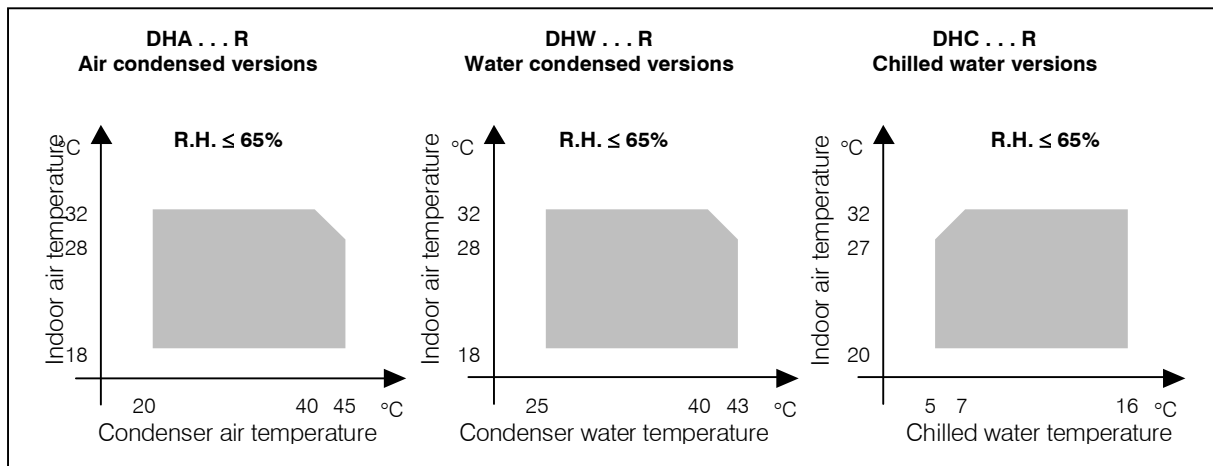

1.3 Cooling circuit

The entire refrigerating circuit is assembled in our production line including all pipe work and using only primary brand for components. The workers involved in the welding and pipe work process are qualified by a third part according CEE 97/23. The DX unit are precharged with dry nitrogen for "A", "D" and with R410A refrigerant for "W", "F", "Q", "K" versions.

Compressors

On **INNOV@** units only primary brand scroll compressors are installed. Scroll compressor represent for CCAC units the best solution in terms of efficiency and reliability. The internal compression ratio is very close to the typical operating condition of CCAC giving the maximum in terms of COPs and the perfect balanced pressures at start up gives big advantages to the e_motor in terms of reliability, mainly in this field where frequent start up may be possible. All motors are thermally protected with an internal sensors chain: in case of overload this sensor opens without giving contacts to the connection box.

Cooling components

- Molecular mesh activated-alumina filter dryer.
- Flow indicator with humidity indicator (indications are provided directly on the sight glass).
- Thermostatic valve with external equalization and integrated MOP function or electric valve (optional).
- High and low pressure switches.
- Schrader valves for checks and/or maintenance.

Electric control board

Electric control board: The electric control board is constructed and wired in accordance with Directives 73/23/EEC and 89/336/EEC and related standards. The board may be accessed through a door after the main switch has been turned off. All the remote controls use 24 V signals powered by an insulating transformer situated on the electric control board.

- The mechanical safety devices such as the high pressure switched are of the kind that trigger directly; their efficiency will not be affected by any faults occurring in the microprocessor control circuit, in compliance with 97/23 PED.

Microprocessor control

The microprocessor built into the unit allows the different operating parameters to be controlled from a set of pushbuttons situated on the electric control board:

- Switching On/Off of compressor(s) to maintain the temperature set point T inside the shelter.
- Alarm management : - High / Low pressure;
- Dirty filters alarm (optional);
- Air flow alarm.
- Alarm signalling.
- Display of operating parameters.
- RS232, RS485 serial output management (optional).
- Phase sequence error (not displayed by the mP, but prevents the compressor from starting up) (only DX).

See microprocessor control manual for further details, also in relation to particular customer specifications.

Fig. 3 1 circuit - basic cooling circuit (DX version)

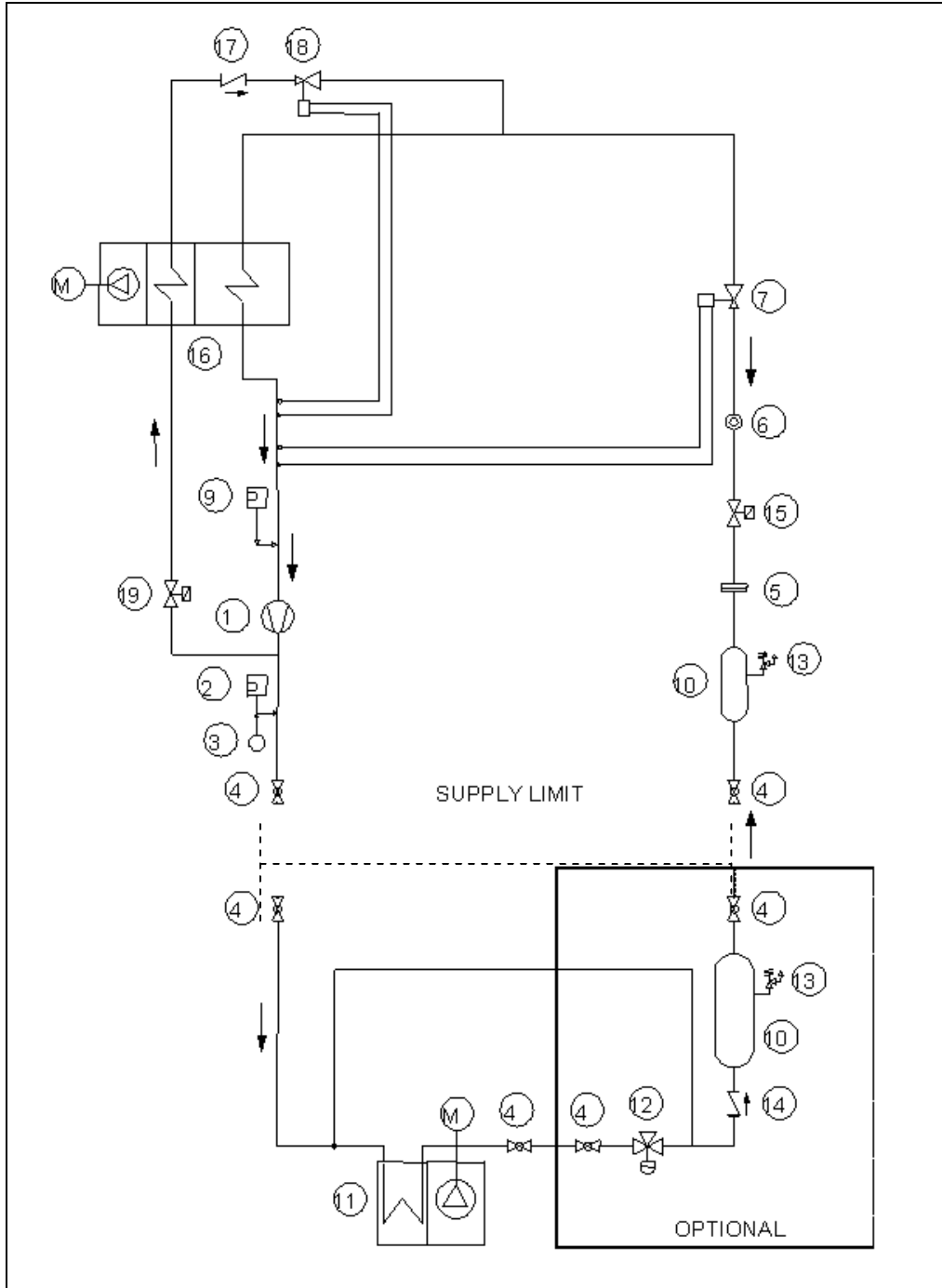

Pos.	Description	Pos.	Description
1	Compressor	11	Condenser coil
2	HP pressure switch	12	Flooding valve
3	Pressure transmitter (Opt.)	13	Safety valve
4	Ball valve	14	Check valve
5	Refrigerant filter	15	Solenoid valve
6	Sight glass	16	Hot gas coil (Opt.)
7	Thermostatic valve	17	Hot gas check valve (Opt.)
8	Evaporating coil	18	Hot gas thermostatic valve (Opt.)
9	LP pressure switch	19	Hot gas solenoid valve (Opt.)
10	Liquid receiver	-	

Fig. 4 2 circuits - basic cooling circuit (DX version)

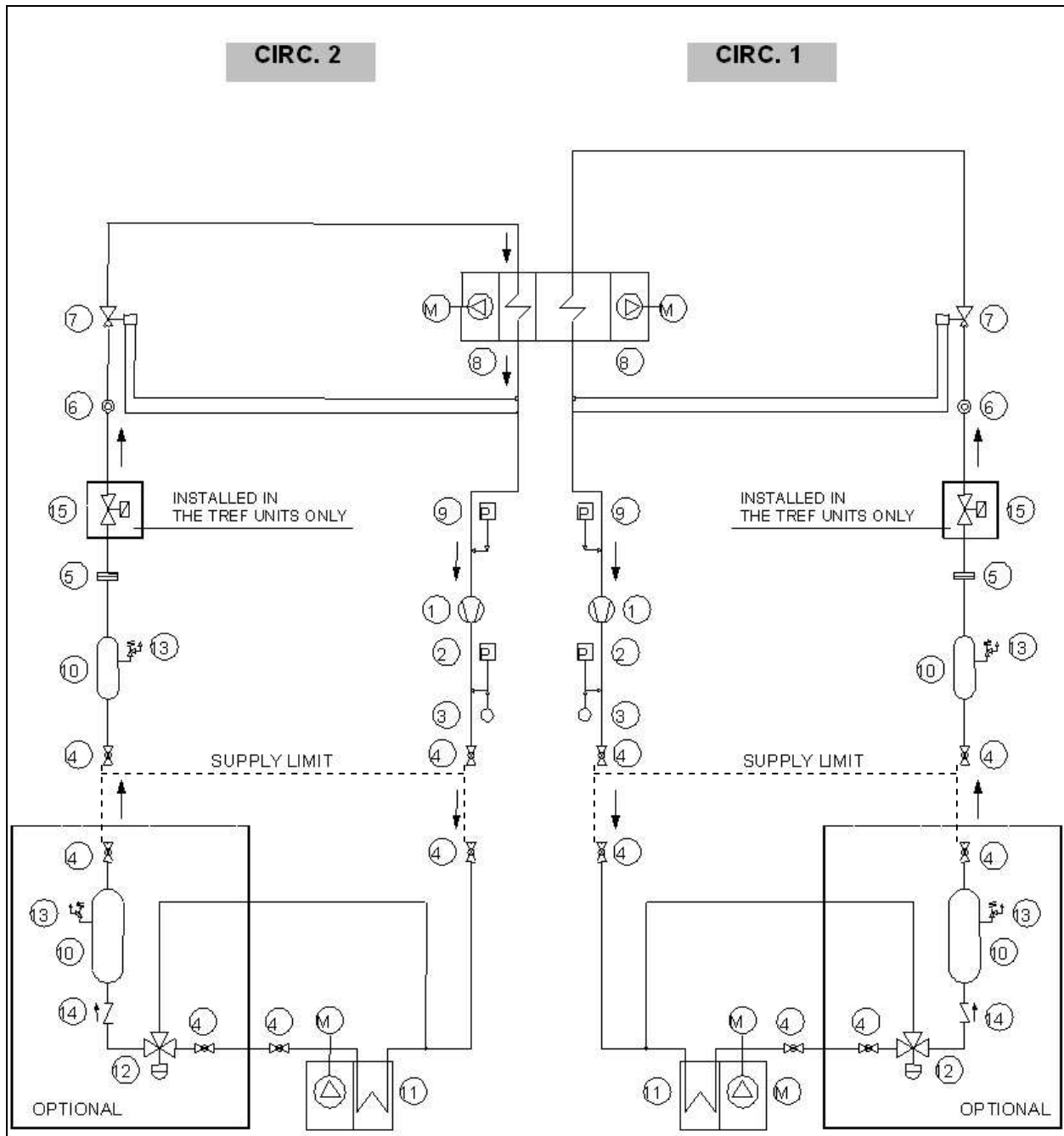

Pos.	Description	Pos.	Description
1	Compressor	9	LP pressure switch
2	HP pressure switch	10	Liquid receiver
3	Pressure transmitter (Opt.)	11	Condenser coil
4	Ball valve	12	Flooding valve
5	Refrigerant filter	13	Safety valve
6	Sight glass	14	Check valve
7	Thermostatic valve	15	Solenoid valve
8	Evaporating coil	-	

Fig. 5 Basic cooling circuit (CW version)

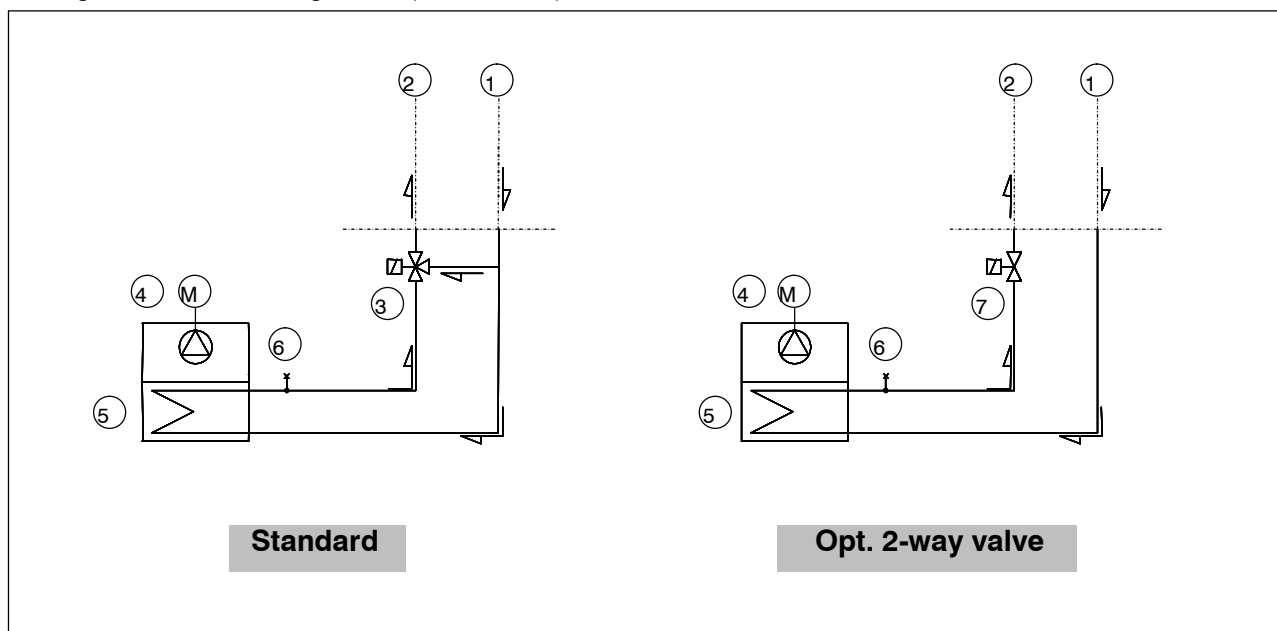

Pos.	Description	Pos.	Description
1	Chilled water inlet	5	Coil heat exchanger
2	Chilled water outlet	6	Breather valve
3	3-way valve	7	2-way valve (Opt.)
4	Plug fan	-	

1.4 Installation warnings

General rules

- When installing or servicing the unit, you must strictly follow the rules provided in this manual, comply with the directions on the units themselves and take all such precautions as are necessary.
- The fluids under pressure in the cooling circuit and the presence of electrical components may cause hazardous situations during installation and maintenance work.



All work on the unit must be carried out by qualified personnel only, trained to do their job in accordance with current laws and regulations.

- Failure to comply with the rules provided in this manual or any modification made to the unit without prior authorisation will result in the immediate invalidation of the warranty.



Warning; Before performing any kind of work on the unit, make sure it has been disconnected from the power supply.

2 Inspection / Transport / Positioning

2.1 Inspection on receipt

On receiving the unit, check that it is perfectly intact: the unit left the factory in perfect conditions; immediately report any signs of damage to the carrier and note them on the "Delivery Slip" before signing it.

LENNOX or its agent must be promptly notified of the entity of the damage. The Customer must submit a written report describing every significant sign of damage.

2.2 Lifting and transport

While the unit is being unloaded and positioned, utmost care must be taken to avoid abrupt or violent manoeuvres. The unit must be handled carefully and gently; avoid using machine components as anchorages or holds and always keep it in an upright position.

The unit should be lifted using the pallet it is packed on; a transpallet or similar conveyance means should be used.



Warning: in all lifting operations make sure that the unit is securely anchored in order to prevent accidental falling or overturning.

2.3 Unpacking

The packing must be carefully removed to avoid the risk of damaging the unit. Different packing materials are used: wood, cardboard, nylon etc. It is recommended to keep them separately and deliver them to suitable waste disposal or recycling facilities in order to minimise their environmental impact.

2.4 Positioning

Bear in mind the following aspects when choosing the best site for installing the unit and the relative connections:

- positioning and dimensions of the coupling flanges and refrigerant connections;
- location of power supply;
- solidity of the supporting floor.

It is recommended to first prepare holes in the floor/wall for passing through the power cables and for the air outlet (down flow units).

The dimensions of the air outlet and the positions of the holes for the screw anchors and power cables are shown below:

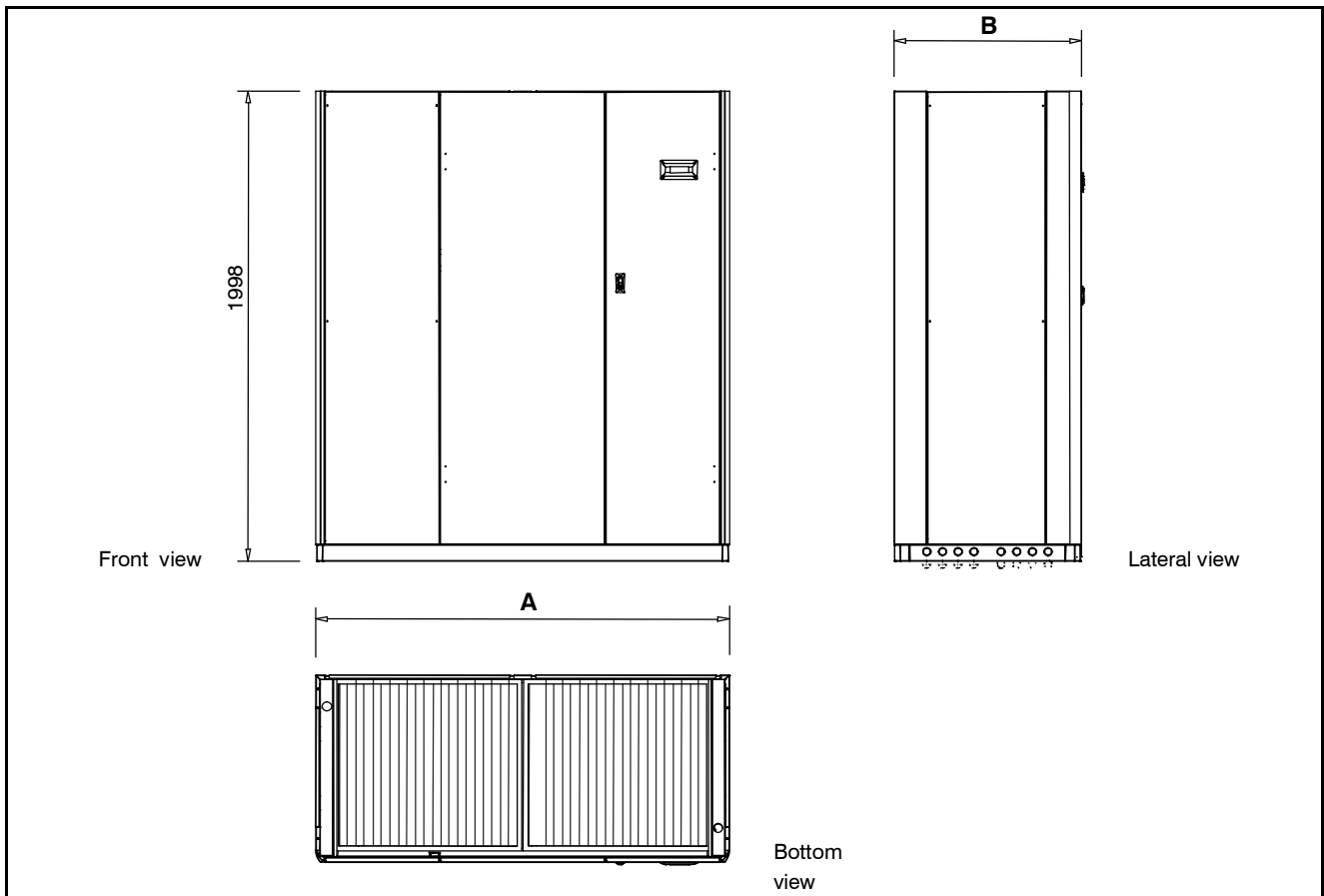

Model	A (mm)	B (mm)
DX version		
DHADR0201 - DHAUR0201 DHADR0251 - DHAUR0251	1010	795
DHADR0281 - DHAUR0281 DHADR0311 - DHAUR0311	1270	795
DHADR0401 - DHAUR0401 DHADR0272 - DHAUR0272 DHADR0302 - DHAUR0302 DHADR0362 - DHAUR0362 DHADR0422 - DHAUR0422 DHADR0452 - DHAUR0452	1760	795
DHADR0532 - DHAUR0532 DHADR0592 - DHAUR0592	2020	795
DHADR0602 - DHAUR0602 DHADR0692 - DHAUR0692 DHADR0762 - DHAUR0762	2510	795
DHADR1002 - DHAUR1002	2510	950
DHADR1204 - DHAUR1204	3180	950

Model	A (mm)	B (mm)
CW version		
DHCDR0300 - DHCUR0300 DHCDR0380 - DHCUR0380	1010	795
DHCDR0450 - DHCUR0450 DHCDR0550 - DHCUR0550	1270	795
DHCDR0400 - DHCUR0400 DHCDR0500 - DHCUR0500 DHCDR0650 - DHCUR0650 DHCDR0750 - DHCUR0750	1760	795
DHCDR0890 - DHCUR0890 DHCDR1090 - DHCUR1090	2020	795
DHCDR0900 - DHCUR0900 DHCDR1000 - DHCUR1000 DHCDR1200 - DHCUR1200	2510	795
DHCDR1500 DHCDR1800	2510	950
DHCDR2100	3160	950

3 Installation

The **INNOV@** air-conditioning unit is suitable for all environments except aggressive ones. Do not place any obstacles near the units and make sure that the air flow is not impeded by obstacles and/or situations causing back suction.

Fig. 7 Service area

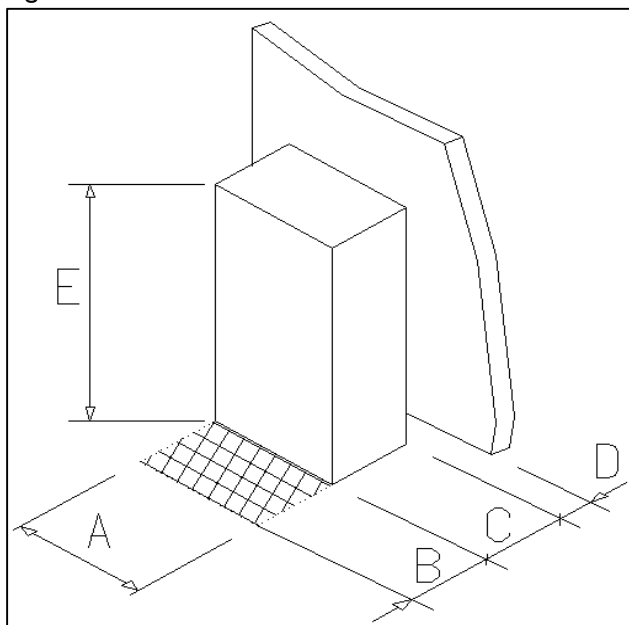

Model	A (mm)	B (mm)	C (mm)	D (mm)	E (mm)
CW version					
DHCDR0300 - DHCUR0300 DHCDR0380 - DHCUR0380	1010	750	795	10	1998
DHCDR0450 - DHCUR0450 DHCDR0550 - DHCUR0550	1270	750	795	10	1998
DHCDR0400 - DHCUR0400 DHCDR0500 - DHCUR0500 DHCDR0650 - DHCUR0650 DHCDR0750 - DHCUR0750	1760	750	795	10	1998
DHCDR0890 - DHCUR0890 DHCDR1090 - DHCUR1090	2020	750	795	10	1998
DHCDR0900 - DHCUR0900 DHCDR1000 - DHCUR1000 DHCDR1200 - DHCUR1200	2510	750	795	10	1998
DHCDR1500 DHCDR1800	2510	750	950	10	1998
DHCDR2100	3160	750	950	10	1998

Model	A (mm)	B (mm)	C (mm)	D (mm)	E (mm)
DX version					
DHADR0201 - DHAUR0201 DHADR0251 - DHAUR0251	1010	750	795	10	1998
DHADR0281 - DHAUR0281 DHADR0311 - DHAUR0311	1270	750	795	10	1998
DHADR0401 - DHAUR0401 DHADR0272 - DHAUR0272 DHADR0302 - DHAUR0302 DHADR0362 - DHAUR0362 DHADR0422 - DHAUR0422 DHADR0452 - DHAUR0452	1760	750	795	10	1998
DHADR0532 - DHAUR0532 DHADR0592 - DHAUR0592	2020	750	795	10	1998
DHADR0602 - DHAUR0602 DHADR0692 - DHAUR0692 DHADR0762 - DHAUR0762	2510	750	795	10	1998
DHADR1002 – DHAUR1002	2510	750	950	10	1998
DHADR1204 – DHAUR1204	3180	750	950	10	1998

The following steps should be carried out to ensure proper installation:

- Apply a anti-vibration rubber lining between the unit and the bottom.
- Position the unit on the floor / floorstand (base frame).

The recommended sizes for the power cables and emergency line are shown in the related electrical drawings.

4 Evacuation and Charging Operations



This type of work must be carried out by qualified personnel only trained to do their job in accordance with current laws and regulations.

4.1 Introductions

The contemporaneous presence of liquid and vapour requires for both to be in a state of saturation (Gibb's law), as shown in Fig. 8. In thermal equilibrated conditions, the pressure in the tank corresponds to the ambient temperature. Withdrawal of refrigerant from the tank has following effects:

- ... withdrawal of refrigerant charge: pressure drop inside the tank.
- ... pressure drop inside the tank: T drop & change of status.
- ... T drop & change of status: evaporation of part of the liquid, causing a cooling down of the liquid.
- ... cooling of liquid: thermal exchange with ambient air, further evaporation of remaining liquid; the original pressure in the tank will be restored after a certain period of time.

Fig. 8 Gibb's law diagram

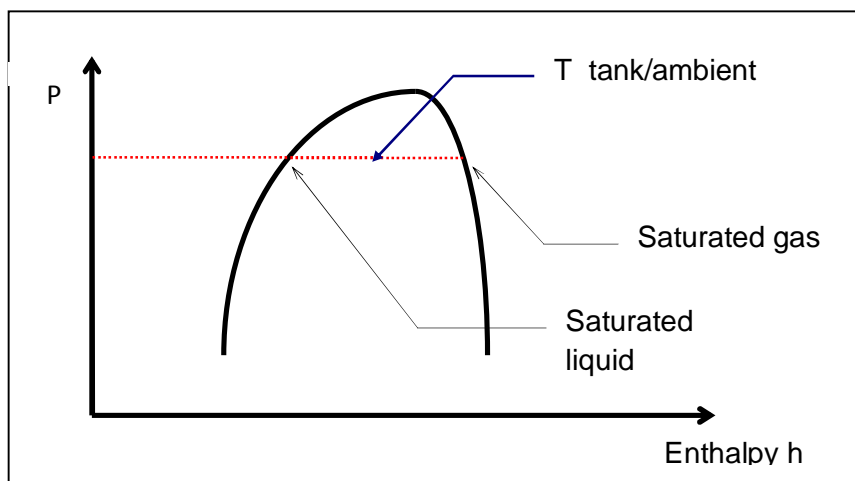

4.2 Full vacuum and charge of the unit

Vacuum cycle

In general it is better to apply a "long" rather than a "hard" vacuum: reaching a low pressure too abruptly may in fact cause that any remaining humidity evaporates instantaneously, thus freezing part of it.

Fig. 9 Vacuum cycle diagram

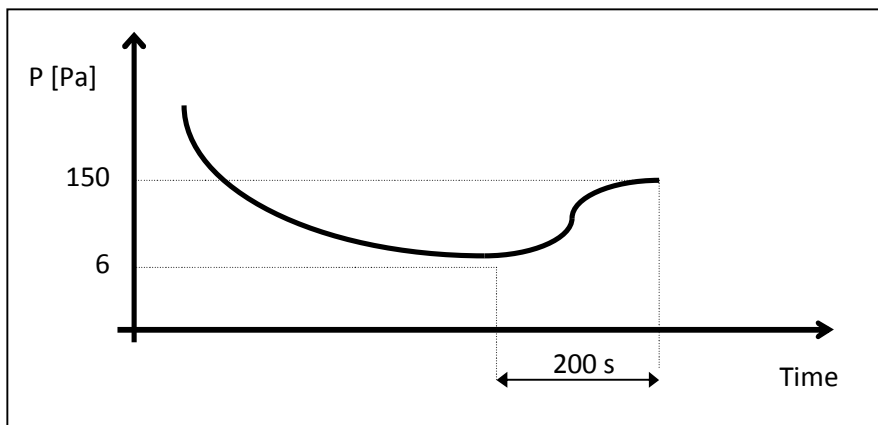

The figure Fig. 9 represents a vacuum cycle and an optimal subsequent pressure rise for the refrigeration devices we manufacture. Generally in bigger refrigeration systems or if there is a suspicion of an extensive quantity of humidity in the refrigeration circuit, the vacuum needs to be “broken” by using anhydrous nitrogen. Then the steps of evacuation need to be repeated as described before. This operation facilitates the removal of remaining and/or frozen humidity during the evacuation process.

4.3 Evacuating a circuit “contaminated” with refrigerant

The first step is to remove the refrigerant from the circuit. To do this a specific machine is necessary with a drying compressor in order to recover the refrigerant. All refrigerants all tend to be dissolve the in oil in the compressor sump). The “Oil” Fig. 10 illustrates a specific property (Charles’ Law) of gases, which are more soluble in liquids as the pressure increases but less soluble as the temperature increases.

Fig. 10 Charles’ law diagram

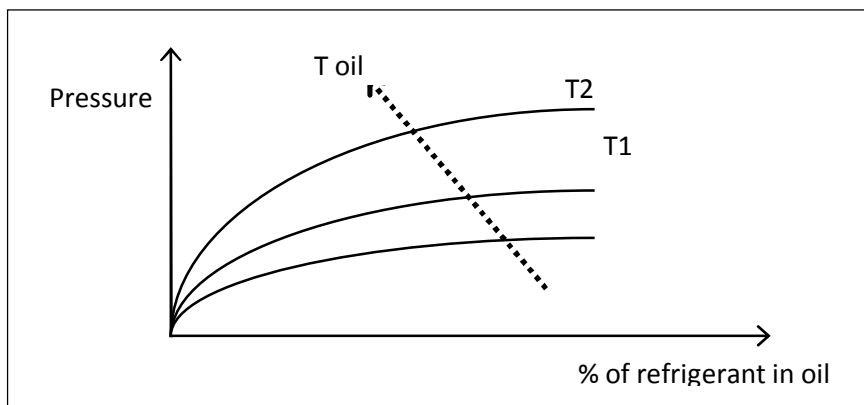

If the oil in the sump is held at a constant pressure, an increase in temperature will significantly reduce the amount of refrigerant dissolved in it, thus ensuring that the lubricating function desired is maintained. The problem of inadequate lubrication occurs if the crankcase is not duly heated, above all after seasonal interruptions when, due to the suction effect of the compressor, there is an abrupt drop in pressure inside the sump, which results in considerable evaporation of the refrigerant previously dissolved in the oil. If heating elements were not installed, this phenomenon would cause two problems:

- 1) The release of refrigerant from the cooling circuit tends to cool down the oil and thus actually creates the opposite effect by keeping more refrigerant dissolved in the oil: for this reason, it is advisable to switch on the crankcase heater during the evacuation process.
- 2) If a high % of refrigerant gets in contact with the Pirani gauge (vacuum sensor), it may “mislead” this sensitive sensor and misinterpret the value for a certain period of time. For this reason (if no machine for recovering refrigerant is available) it is nonetheless advisable to switch on the crankcase heater and to avoid full vacuum before the circuit has been adequately purged of refrigerant. The refrigerant may in fact dissolve in the oil of the vacuum pump, reducing its performance for a long time (hours).

4.4 Charging positions (single point)

The best position to charge the unit is the section between the thermostatic valve and the evaporator. take care to avoid the fixing of the thermostat bulb until the operation is completed. It is important to ensure that the valve orifice remains open in order to allow the passage of refrigerant also towards the condenser / liquid receiver.

If possible, avoid the charge of refrigerant into the suction line of the compressor as this may cause excessive dilution of the lubricant.

In case of air cooled units, in the attached “Piping Design Criteria” is described how to calculate the estimate refrigerant charge.

5 Electrical Connections

5.1 Generalities



Before carrying out any job on electrical parts, make sure the power supply is disconnected

Check that the mains electricity supply is compatible with the specifications (voltage, number of phases, frequency) shown on the unit rating plate. The power connection for single-phase loads is to be made with a three-pole cable and "N" wire at the centre of the star (optional: power supply w/o neutral).



The size of the cable and line protections must conform to the specifications provided in the wiring diagram (attached to the documentation of the unit).

The supply voltage may not undergo fluctuations exceeding $\pm 10\%$ and the unbalance between phases must always be below 2%.



The above operating conditions must always be complied with: failure to ensure said conditions will result in the immediate invalidation of the warranty.

The electrical connections must be made in accordance with the information shown in the wiring diagram provided with the unit and with current and local regulations. An earth connection is **mandatory**. The installer must connect the earthing wire using the earthing terminal situated on the electric control board (yellow and green wire). The power supply to the control circuit is taken from the power line through an insulating transformer situated on the electric control board.

The control circuit is protected by suitable fuses or automatic breakers depending on the unit size.

6 Operating Diagrams

DOWNFLOW

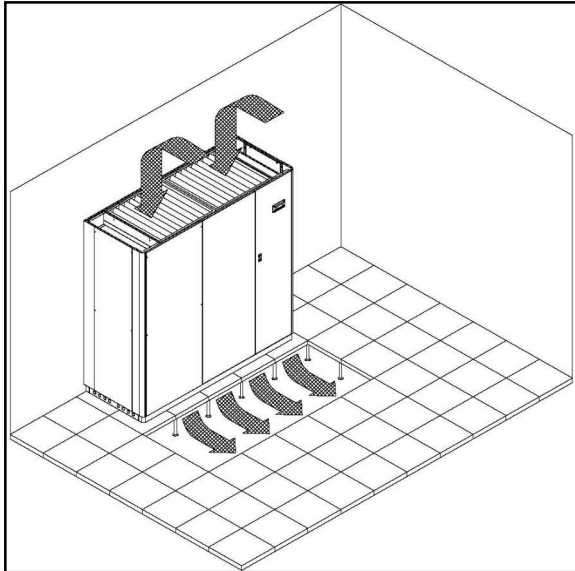

UPFLOW

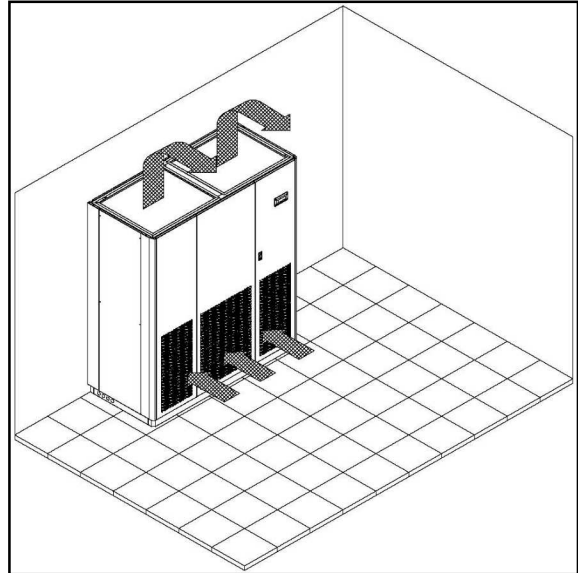

DISPLACEMENT

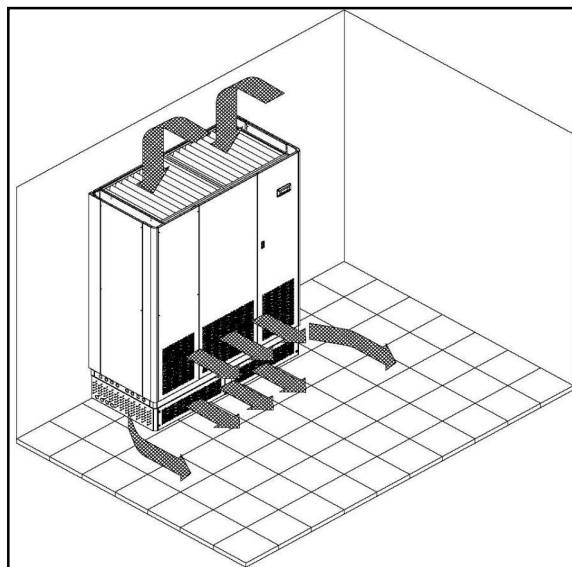

7 Start-Up

7.1 Preliminary checks

- Check that the electrical connections have been made properly and that all the terminals **are securely tightened**. This check should also be included in a periodic six-month inspection.
 - Check that the voltage at the RST terminals is $400\text{ V} \pm 10\%$ and make sure the yellow indicator light of the phase sequence relay is on (only DX versions). The phase sequence relay is positioned on the electric control board; if the sequence is not duly observed, it will not enable the machine to start.
 - Make sure there are no refrigerant leakage that may have been caused by accidental impacts during transport and/or installation (monobloc unit).
- Check the power supply to the crankcase heater, where present



The heating elements must be turned on at least 12 hours before the unit is started. They are automatically activated when the main switch is put on. Their function is to raise the T of the oil in the sump and limit the quantity of refrigerant dissolved in it.

To verify whether the heating elements are working properly, check the lower part of the compressors: it should be warm or in any case at a temperature 10 - 15 °C higher than the ambient temperature.

Fig. 12 Charles' law diagram

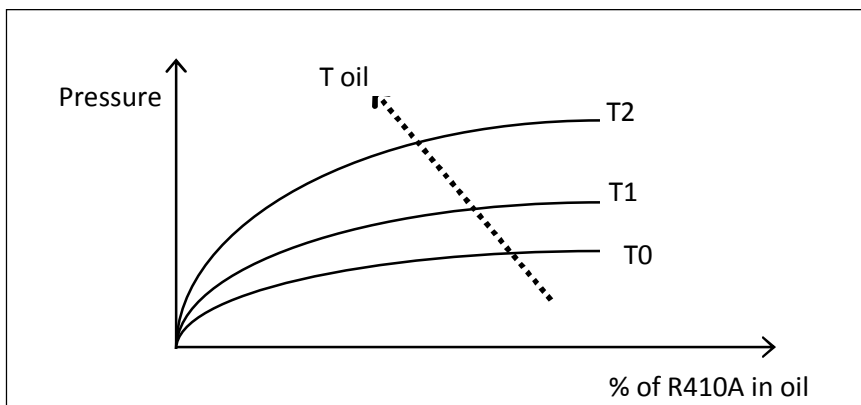

The diagram above illustrates a specific property of gases (Charles' Law), which are more soluble in liquids as the pressure increases but less soluble as the temperature increases: if the oil in the sump is held at a constant pressure, an increase in temperature will significantly reduce the amount of refrigerant dissolved in it, thus ensuring that the desired lubricating function is maintained.

7.2 Starting operations

Before starting the unit, turn the main switch on, select the operating mode desired from the control panel and press the "ON" button on the control panel.

If the unit fails to start up, check if the service thermostat has been set according to the nominal values provided.



You should not disconnect the unit from the power supply during periods when it is inoperative but only when it is to be taken out of service for a prolonged period (e.g. at the end of the season).

7.3 Checks during operations

Check the phase sequence relay (only DX versions) on the control board to verify whether the phases occur in the correct sequence: if they do not, disconnect the unit from power supply and invert two phases of the incoming three-pole cable. Never attempt to modify internal electrical connections: any undue modifications will immediately invalidate the warranty.

7.4 Checking the refrigerant charge (DX versions)

- After a few hours of operation, check whether the liquid level indicator has a green ring: a yellow colour indicates the presence of humidity in the circuit. In such a case the circuit must be dehumidified by qualified personnel.
- Large quantities of bubbles should not appear through the liquid level indicator. A constant passage of numerous bubbles may indicate that the refrigerant level is low and needs to be topped up.
- Make sure the overheating of the cooling fluid is limited to between 5 and 8 °C: to this end:
 - 1) read the temperature indicated by a contact thermometer placed on the condenser outlet pipe;
 - 2) read the temperature indicated on the scale of a pressure gauge connected to the liquid inlet at the condenser outlet; refer to the pressure gauge scale for the refrigerant R410A.

The degree of Sub-cooling is given by the difference between the temperatures thus determined.
- Make sure that the Sub-cooling of the cooling fluid is limited to between 3 and 5°C; to this end:
 - 1) read the temperature indicated by a contact thermometer placed on the condenser outlet pipe;
 - 2) read the temperature indicated on the scale of a pressure gauge connected to the liquid inlet at the condenser outlet; refer to the pressure gauge scale for the refrigerant R410A.



Warning: TREF units are design for R410A refrigerant.
Any top-ups must be made using the same type of refrigerant. This operation is to be considered extraordinary maintenance work and must be performed by qualified personnel only



Warning: The refrigerant R410A requires “POE” polyolester oil of the type and viscosity indicated on the compressor rating plate. For no reason should oil of a different type be introduced into the oil circuit.



Warning: The air cooled (split) unit are Factory pre-charge with Nitrogen

8 Setting Operating Parameters

8.1 Generalities

All the control devices are set and tested in the factory before the unit is dispatched. However, after the unit has been in service for a reasonable period of time you can perform a check on the operating and safety devices.

The settings are shown in tab. 5 e tab. 6.



All servicing of the equipment is to be considered extraordinary maintenance and may be carried out BY QUALIFIED TECHNICIANS ONLY: incorrect settings may cause serious damage to the unit and injuries to persons.

The operating parameters and control system settings configurable by means of the microprocessor control are password protected if they have a potential impact on the integrity of the unit.

tab. 5 Setting of control devices

Control device		Set point	Differential
Differential air pressure switch (air flow)	Pa	50	30
Differential air pressure switch (dirty filter)	Pa	70	20

Values to be calibrated depending on the application.

tab. 6 Setting of control and safety devices

Control device		Activation	Differential	Resetting
Maximum pressure switch	Bar-g	38	4	Manual
Minimum pressure switch	Bar-g	2.0	1.5	Automatic
Modul. condensation control devices (DX versions)	Bar-g	18	10	
Time lapse between two compressor starts	s	480	-	-

8.2 Maximum pressure switch

The high pressure switch stops the compressor when the outlet pressure exceeds the set value.



Warning: do not attempt to change the setting of the maximum pressure switch: Should the latter fail to trip in the event of a pressure increase, the pressure relief valve will open.

The high pressure switch must be manually reset; this is possible only when the pressure falls below the differential set (see table 6).

8.3 Minimum pressure switch

The low pressure switch stops the compressor when the inlet pressure falls below the set value for more than 1 second.

The switch is automatically reset when the pressure rises above the set differential (see table 6).

9 Maintenance

The only operations to be performed by the user are to switch the unit on and off. All other operations are to be considered maintenance work and must thus be carried out by qualified personnel trained to do their job in accordance with current laws and regulations.

9.1 Warnings



All the operations described in this chapter MUST ALWAYS BE PERFORMED BY QUALIFIED PERSONNEL ONLY.



Before carrying out any work on the unit or accessing internal parts, make sure you have disconnected it from the mains electricity supply.



The upper part and the outlet pipe of the compressor reach high temperatures. Be especially careful when working in the surrounding area with the panels off.



Be especially careful when working in proximity to finned coils since the 0.11 mm-thick aluminum fins can cause superficial injuries due to cuts.



After completing maintenance jobs, always replace the panels enclosing the units and secure them with the fastening screws provided.

9.2 Generalities

To guarantee a constantly satisfactory performance over time, it is advisable to carry out routine maintenance and checks as described below. The indications below are related to standard tear and wear.

tab. 7 Routine maintenance

Operation	Frequency
Check the efficiency of all the control and safety devices.	Once a year
Check the terminals on the electric control board and compressor terminal boards to ensure that they are securely tightened. The movable and fixed contacts of the circuit breakers must be periodically cleaned and replaced whenever they show signs of deterioration.	Once a year
Check the refrigerant level by means of the liquid level indicator.	Every 6 months
Check the efficiency of the differential air pressure switch and dirty filter differential pressure switch (option).	Every 6 months
Check the condition of the air filter and replace it if necessary.	Every 6 months
Check the humidity indicator (green = dry, yellow = humid) on the liquid level indicator; if the indicator is not green as shown on the indicator sticker (see pag.20).	Every 6 months
Check the refrigerant charge (see page 20).	Every 6 months

Fig. 13 Inspecting the air filter (Downflow “CW” and “DX” version)

Open the front panels to access the air filter compartment.
 Pull out the air filter.
 Check the condition of the filter and replace it if necessary.

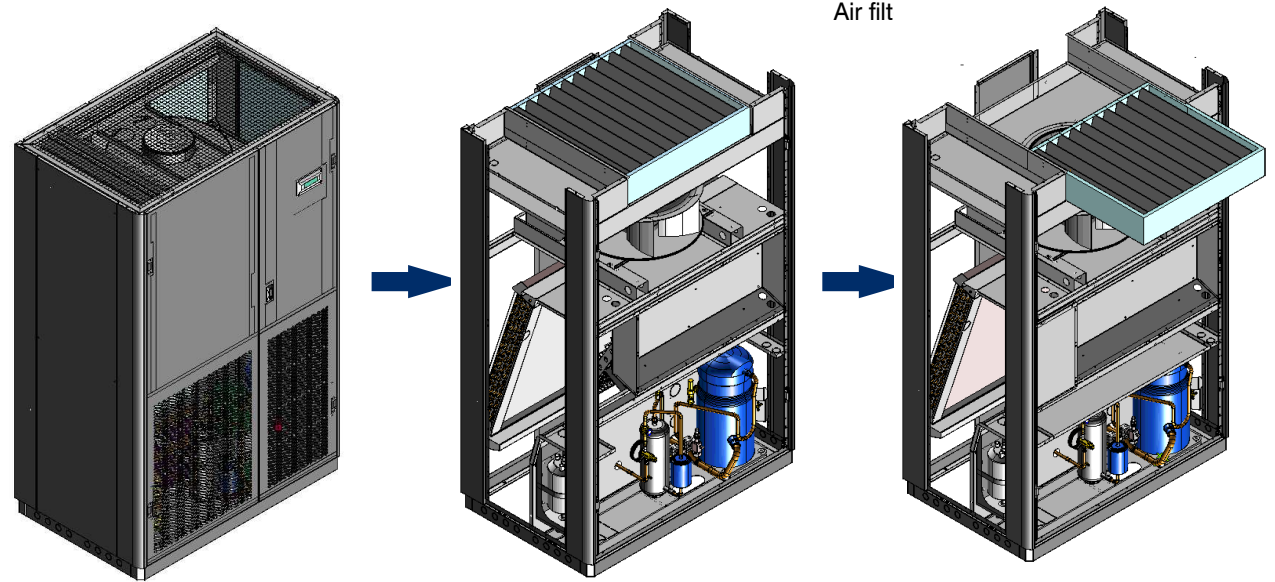

Fig. 14 Inspecting the air filter (Upflow “CW” and “DX” version)

Open the front panels to access the air filter compartment.
 Remove the screws and the metallic support (tools not needed).
 Extract the filter on the right.
 Pull on the right side the second filter and then extract it.

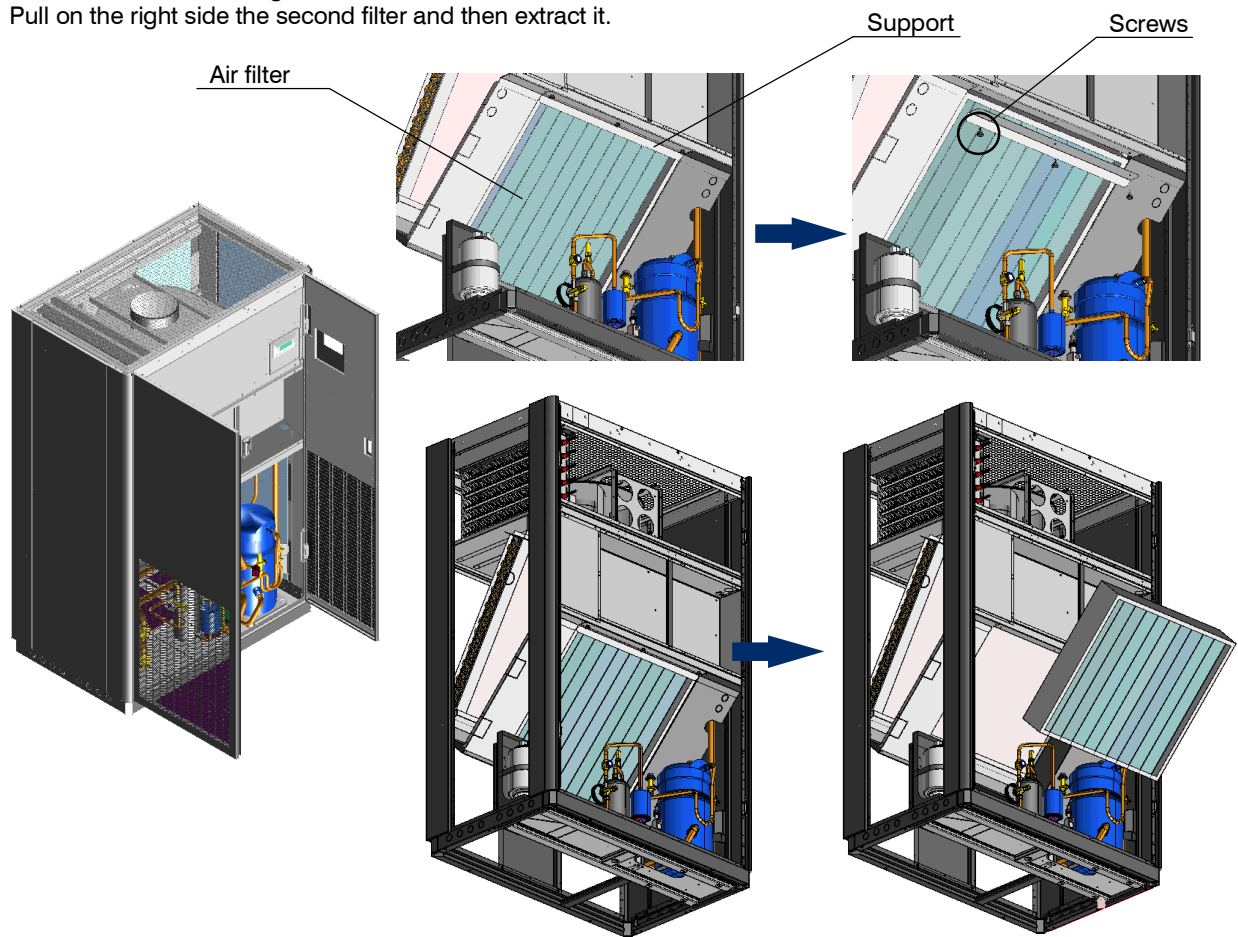
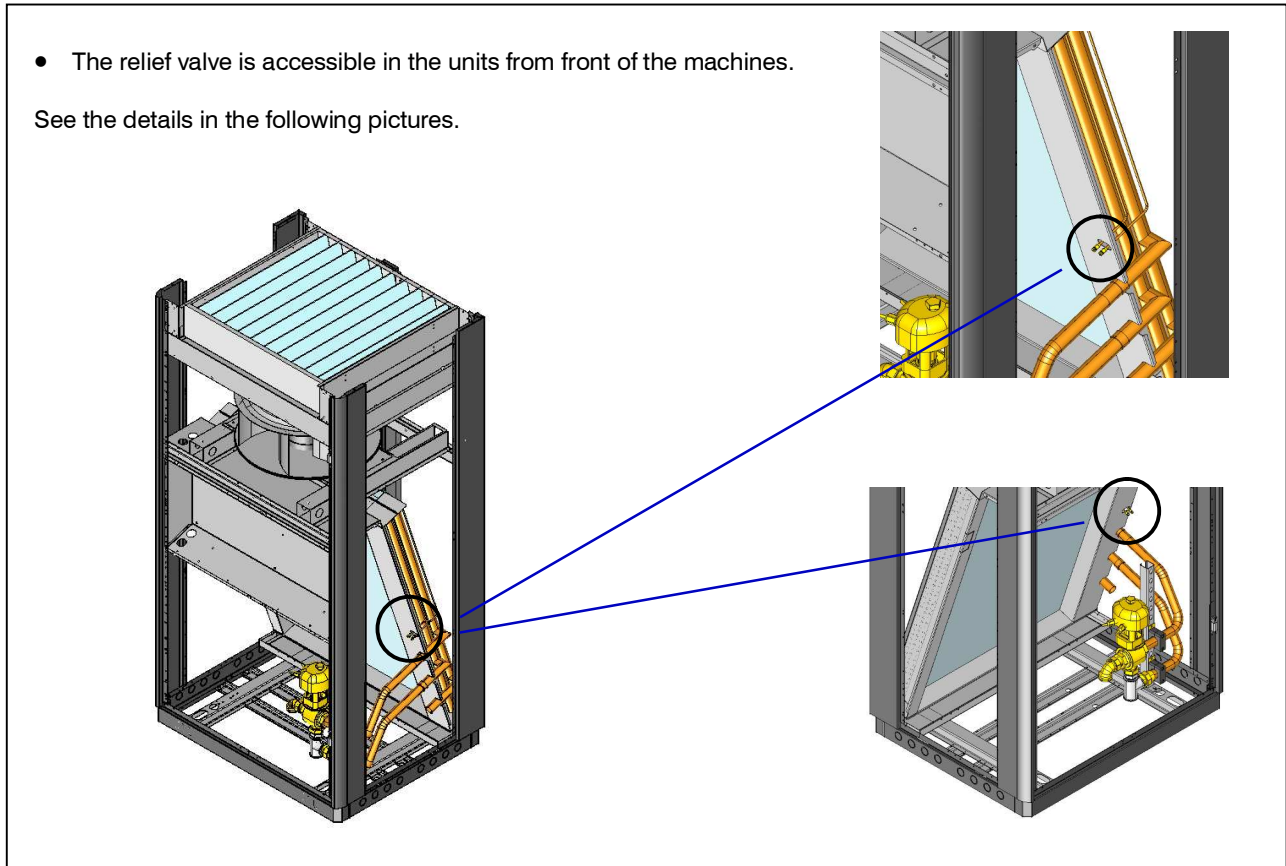
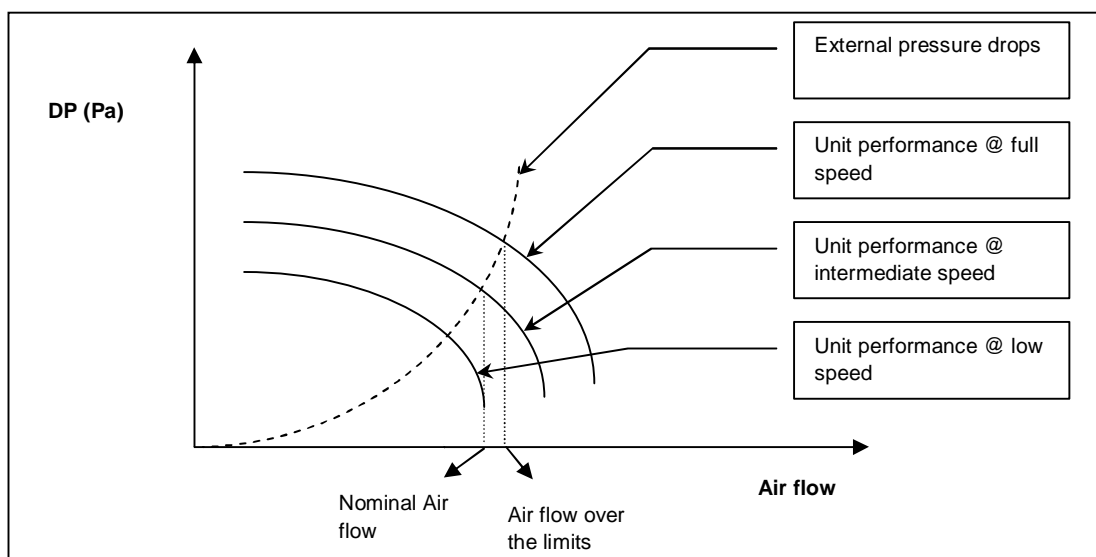

Fig. 15 Purging the air out of the water coil (CW version)



9.3 Set the right fan speed

The adopted fans are of the backward curved blades type in combination with a 4 poles e-motor. This kind of fan has very high performances so that it's speed has to be reduced in order to match to the nominal air flow with the real external pressure drops: in case of wrong selection, the air flow may exceed the limits with possible water dragging out from the coils (down flow units) or in case of DC units. a not sufficient airflow can cause ice on the coil.



The fan speed has to be selected according to the enclosed table.

In the EC fans the rotation speeds are selected with different values of the control tension (0 - 10V). If in the unit is present the advanced control the right value of the control tension is set by the keyboard present in the advanced control.

With the basic control the control tension is set with a manual potential installed in the E-Panel. To know the tension set with the potential it is necessary to use an external tool (Voltmeter).

9.4 EC fans

tab. 8 AESP (Pa) with the different control tensions (0 - 10 V) for the EC fan(s)

DHADR 201 - 251	1 V	2 V	3 V	4 V	5 V	6 V	7 V	8 V	9 V	10 V
Base + Filter	11,5	92,5	173,5	254,5	335,5	416,5
Base + Filter + Heater	49,6	130,6	211,6	292,6	373,6
Base + Filter + Add coil	64,4	145,4	226,4	307,4	388,4
Freecooling + Filter	47,3	128,3	209,3	290,3	371,3
Freecooling + Filter + Heater	4,3	85,3	166,3	247,3	328,3
Freecooling + Filter + Add coil	19,1	100,1	181,1	262,1	343,1

DHADR 272 -302 -362 -422 -452	1 V	2 V	3 V	4 V	5 V	6 V	7 V	8 V	9 V	10 V
Base + Filter	15,9	96,9	177,9	258,9	339,9	420,9
Base + Filter + Heater	58,7	139,7	220,7	301,7	382,7
Base + Filter + Add coil	72,4	153,4	234,4	315,4	396,4
Freecooling + Filter	76,5	157,5	238,5	319,5	400,5
Freecooling + Filter + Heater	38,3	119,3	200,3	281,3	362,3
Freecooling + Filter + Add coil	52,0	133,0	214,0	295,0	376,0

DHADR 602 - 392 - 762	1 V	2 V	3 V	4 V	5 V	6 V	7 V	8 V	9 V	10 V
Base + Filter	10,0	91,0	172,0	253,0	334,0	415,0
Base + Filter + Heater	52,8	133,8	214,8	295,8	376,8
Base + Filtro + Add coil	68,2	149,2	230,2	311,2	392,2
Freecooling + Filter	43,1	124,1	205,1	286,1	367,1
Freecooling + Filter + Heater	4,9	85,9	166,9	247,9	328,9
Freecooling + Filter + Add coil	20,0	101,0	182,0	263,0	344,0

9.5 Repairing the cooling circuit



While performing repairs on the cooling circuit or maintenance work on the compressors, make sure the circuit is left open for as less time as possible. Even if briefly exposed to air, ester oils tend to absorb large amounts of humidity, which results in the formation of weak acids.

If the cooling circuit has undergone any repairs, the following operations must be carried out:

- tightness test;
- evacuation and drying of the cooling circuit;
- charging with refrigerant.



If the system has to be drained, always recover the refrigerant present in the circuit using suitable equipment; the refrigerant should be handled exclusively in the liquid phase.

9.6 Tightness test

Fill the circuit with anhydrous nitrogen supplied from a tank with a pressure-reducing valve until the pressure rises to 22 bars.



During the pressurization phase, do not exceed a pressure of 22 bars on the compressor low pressure side.

The presence of any leaks must be determined using special leak detectors. Should any leaks be detected during the test, empty out the circuit before repairing the leaks with suitable alloys.



Do not use oxygen in the place of nitrogen as a test agent, since this would cause a risk of explosion.

9.7 Hard vacuum and drying of cooling circuit

To achieve a hard vacuum in the cooling circuit it is necessary to use a pump capable of generating a high degree of vacuum, i.e. 150 Pa of absolute pressure with a capacity of approximately 10 m³/h. If such a pump is available, one evacuation will normally suffice to achieve an absolute pressure of 150 Pa. If there is no such vacuum pump available, or whenever the circuit has remained open for long periods of time, you are strongly recommended to adopt the triple evacuation method. This method is also recommended when there is a presence of humidity within the circuit. The vacuum pump should be connected to the inlets.

The procedure to be carried out is as follows:

- Evacuate the circuit until you reach an absolute pressure of at least 350 Pa: at this point inject nitrogen into the circuit until you reach a relative pressure of about 1 bar.
- Repeat the step described above.
- Carry out the step described above for the third time, but in this case attempting to reach the hardest vacuum possible.

Using this procedure you can easily remove up to 99% of pollutants.

9.8 Recharging with refrigerant R410A

- Connect the tank of refrigerant gas to the male 1/4 SAE inlet situated on the liquid line after discharging a little gas to eliminate air in the connection pipe.
- **Fill with refrigerant in liquid form** until you reach 75% of the total charge. For monobloc unit (water cooled), the correct refrigerant charge is shown in silver plate. For split units (air cooled) check the "Piping design criteria" attached to the unit documentation.
- Then connect to the inlet on the pipe between the thermostatic valve and evaporator and complete the charging process with the refrigerant **in liquid form** until no more bubbles can be seen on the liquid level indicator and the operating parameters specified in section 7.4 have been reached (see piping design criteria).



These units are designed for the exclusive use of R410A refrigerant and should not be charge with different refrigerants without the written permission of the manufacturer.

9.9 Environmental protection

The law implementing the regulations (reg. EEC 2037/00) which govern the use of ozone-depleting substances and greenhouse gases bans the dispersal of refrigerant gases in the environment and requires whoever is in their possession to recover them and, at the end of their useful life, either to return them to the dealer or take them to a suitable waste disposal facility. The refrigerant HFC R410A is not harmful to the ozone layer but is included among the substances responsible for the greenhouse effect and thus falls within the scope of the aforesaid regulations.



Therefore, special care should be taken when carrying out maintenance work to minimize refrigerant leaks.

10 Troubleshooting

On the next pages you will find a list of the most common reasons that may cause the package unit to fail or any malfunction. This causes are broken down according to easily identifiable symptoms.



You should be extremely careful when attempting to implement any of the possible remedies suggested: overconfidence can result in injuries, even serious ones, to inexperienced individuals. Therefore, once the cause has been identified, you are advised to contact the manufacturer or a qualified technician for help.

FAULT	POSSIBLE CAUSES	CORRECTIVE ACTIONS
The unit does not start	No power supply.	Check if power is being supplied both to the primary and auxiliary circuits.
	The electronic card is cut off from the power supply.	Check the fuses.
	Alarms have been released.	Check whether any alarms are signalled on the microprocessor control panel, eliminate the causes and restart the unit.
	The phase sequence is wrong.	Invert two phases in the primary power line after disconnecting them upstream from the unit.
The compressor is noisy	The compressor is rotating in the wrong direction.	Check the phase sequence relay. Invert the phases on the terminal board after disconnecting the unit and contact the manufacturer.
Presence of abnormally high pressure	Insufficient airflow through the condenser.	Check for the presence of obstructions in the condenser section ventilation circuit. Check whether the condenser coil surface is obstructed. Check the condensation control device (optional).
	Presence of air in the refrigerant circuit, as revealed by the presence of bubbles in the flow indicator also with sub-cooling values exceeding 5 °C.	Drain and pressurise the circuit and check for leaks. Evacuate slowly (for more than 3 hours) until reaching a pressure of 0.1 Pa and then recharge in the liquid phase.
	Unit overcharged, as revealed by a Sub-cooling of more than 8 °C.	Drain the circuit.
	Thermostatic valve and/or filter obstructed. These symptoms may also occur in the presence of an abnormally low pressure.	Check the temperatures upstream and downstream from the valve and filter and replace them if necessary.
Low condensation pressure	Transducer fault.	Replace the transducer.
	Wrong setting of the condensation control device	Check the efficiency of the condensation control device (optional).
Low evaporation pressure	Malfunctioning of thermostatic valve.	Warming the bulb with your hand, check whether the valve opens and adjust it if necessary. If it does not respond, replace it.
	Filter dryer clogged.	Pressure drops upstream and downstream from the filter should not exceed 2°C. If they do, replace the filter.
	Low condensation temperature.	Check the efficiency of the condensation control device (where present).
	Low level of refrigerant.	Check the refrigerant level by measuring the degree of Sub-cooling; if it is below 2°C replenish the charge.
The compressor does not start	The internal thermal protection device has tripped.	In the case of compressors equipped with a protection module, check the thermal contact. Identify the causes after restarting.
	The circuit breakers or line fuses have been tripped by a short circuit.	Pinpoint the cause by measuring the resistance of the individual windings and the insulation from the casing before restoring power.
	One of the HP or LP pressure switches has tripped.	Check on the microprocessor, eliminate the causes.
	The phases have been inverted in the distribution compartment.	Check the phase sequence relay (only DX).
Air in the hydraulic circuit	During external connections.	Open the valve positioned on the right side over the top of the coil.
Water out from the unit	The drain pan hole is closed.	Open the front panels, remove the sheet metal just below the e-panel (down flow units) and clean it.
	The siphon is missing.	Check for the presence and provide for a new one.
	The air flow is too high.	Reduce the fan speed up to reaching the nominal air flow.
	Unit is not perfectly level	Place correctly the unit.

11 Technical Data

tab. 10 DX unit - air cooled - DHADR - DHAUR

MODELS	DHADR DHAUR	0201	0251	0281	0311	0401
Power supply	V/Ph/Hz	400V / 3Ph + N + PE / 50Hz				
Air flow	m ³ /h	6800		7280		12950
COMPRESSOR						
Type	-	Scroll				
Cooling capacity (24□C; 50% RH; external air T 35□C)	kW	22.92	23.74	27.68	31.56	42.53
Power consumption	kW	5.33	5.65	7.13	7.87	10.71
Nominal current	A	10.14	10.75	13.42	15.14	19.05
FLA	A	17		20	29	
LRA	A	86	98	130		135
Oil charge	l	3.25			4.25	3.30
FINNED EVAPORATOR COIL						
Front surface	m ²	0.68		0.90		1.31
Geometry	-	25 x 22				
Rows	Nr.	5				4
Type of fins	Type	Hydrophilic				
Fin pitch	mm	1.8				
SHR	-	0.93	0.91	0.89	0.83	0.90
FAN SECTION						
Type of fans	-	Radial - EC				
Power supply	V/Ph/Hz	400V / 3Ph / 50Hz				
Fans	Nr.	1				2
Current consumption	A	1.61		2.01		1.53
Power consumption	W	1007		1252		956
AESP	Pa	30				
AESP (max. fan speed)	Pa	367.5		298.4		382.2
FILTER SECTION						
Filter efficiency	-	G4				
Overall surface	m ²	1.44			2.92	
Fire resistance class	-	1				
ELECTRICAL HEATERS						
Total heating capacity	kW	6.4				9.6
Heaters	Nr.	4				6
Material	-	Aluminium				
HOT GAS REHEATING COIL						
Heating capacity	kW	16.50	16.70	-	-	37.20
Front surface	m ²	0.68	0.68	0.90	0.90	1.31
HOT WATER REHEATING COIL						
Heating capacity (water 45/40□C)	kW	16.9	17.2	22.6	22.9	35.6
Front surface	m ²	0.6		0,8		1.2
Water flow	m ³ /h	2949	2973	3930	3993	6187
Water side pressure drop	kPa	14.4	14.6	29	29.8	47.2
Valve pressure drop	kPa	20,6	20,9	36,5	37	14,9
HUMIDIFIER						
Capacity	kg/h	3				8
Power consumption	kW	2.25				6.00
DIMENSIONS						
Height x Lenght x Depth	mm	1998 x 1010 x 795		1998 x 1270 x 795		1998x1760x795
Unit weight	kg	375	385	490	505	595

MODELS	DHADR DHAUR	0272	0302	0362	0422	0452
Power supply	V/Ph/Hz	400V / 3Ph + N + PE / 50Hz				
Air flow	m ³ /h	12950				
COMPRESSOR						
Type	-	Scroll				
Cooling capacity (24□C; 50% RH; external air T 35□C)	kW	26.9	31.9	35.9	41.9	44.3
Power consumption	kW	6.8	8.5	9.8	11.6	12.2
Nominal current	A	12.2	16.2	17.4	21.4	22.6
FLA	A	10	13	14	17	
LRA	A	50	66	74	86	98
Oil charge	l	1.36		1.65	3.25	
FINNED EVAPORATOR COIL						
Front surface	m ²	1.3				
Geometry	-	25 x 22				
Rows	Nr.	3			4	
Type of fins	Type	Hydrophilic				
Fin pitch	mm	1.8				
SHR	-	1.00	0.99	0.98	0.97	0.98
FAN SECTION						
Type of fans	-	Radial - EC				
Power supply	V/Ph/Hz	400V / 3Ph / 50Hz				
Fans	Nr.	2				
Current consumption	A	4.3			4.4	
Power consumption	W	2500			2595	2600
AESP	Pa	30				
AESP (max. fan speed)	Pa	425			355	
FILTER SECTION						
Filter efficiency	-	G4				
Overall surface	m ²	2.92				
Fire resistance class	-	1				
ELECTRICAL HEATERS						
Total heating capacity	kW	9.6				
Heaters	Nr.	3				
Material	-	Aluminium				
HOT GAS REHEATING COIL						
Heating capacity	kW	34.1	33.7		41.6	42.3
Front surface	m ²	1.05				
HOT WATER REHEATING COIL						
Heating capacity (water 45/40□C)	kW	30.7	33	33.5	35.4	36
Front surface	m ²	1.2				
Water flow	m ³ /h	5339	5741	6009	6156	6259
Water side pressure drop	kPa	36.5	41.4	44.9	46.8	48.2
Valve pressure drop	kPa	11.1	12.9	14.1	14.8	15.3
HUMIDIFIER						
Capacity	kg/h	8				
Power consumption	kW	6				
DIMENSIONS						
Height x Length x Depth	mm	1998 x 1750 x 795				
Unit weight	kg	565	580	590	605	615

MODELS	DHADR DHAUR	0532	0592	0602	0692	0762
Power supply	V/Ph/Hz	400V / 3Ph + N + PE / 50Hz				
Air flow	m ³ /h	14150		19415		
COMPRESSOR						
Type	-	Scroll				
Cooling capacity (24□C; 50% RH; external air T 35□C)	kW	53.94	59.08	64.44	71.03	78.59
Power consumption	kW	13.94	16.72	16.14	19.53	22.10
Nominal current	A	26.44	31.48	30.76	35.37	39.00
FLA	A	20	29			32
LRA	A		130			135
Oil charge	l		3.25		3.30	3.25
FINNED EVAPORATOR COIL						
Front surface	m ²	1.5		1.9		
Geometry	-	25 x 22				
Rows	Nr.	4				
Type of fins	Type	Hydrophilic				
Fin pitch	mm	2.1				
SHR	-	0.84	0.80	0.90	0.85	0.81
FAN SECTION						
Type of fans	-	Radial - EC				
Power supply	V/Ph/Hz	400V / 3Ph / 50Hz				
Fans	Nr.	3				
Current consumption	A	4.36			4.93	
Power consumption	W	2718			3074	
AESP	Pa			30		
AESP (max. fan speed)	Pa	274.2			363.0	
FILTER SECTION						
Filter efficiency	-	G4				
Overall surface	m ²	4.49				
Fire resistance class	-	1				
ELECTRICAL HEATERS						
Total heating capacity	kW	9.6		12.8		
Heaters	Nr.	6		8		
Material	-	Aluminium				
HOT GAS REHEATING COIL						
Heating capacity	kW	-	-	51.30	52.70	53.90
Front surface	m ²	1.5		1.9		
HOT WATER REHEATING COIL						
Heating capacity (water 45/40□C)	kW	33.8	34.5	52.32	51.5	53.7
Front surface	m ²	1.1		1.7		
Water flow	m ³ /h	5879	5995	9091	8957	9332
Water side pressure drop	kPa	41.8	43.2	35.7	34.8	37.4
Valve pressure drop	kPa	13.5	14	32.2	31.3	34
HUMIDIFIER						
Capacity	kg/h	8				
Power consumption	kW	6				
DIMENSIONS						
Height x Length x Depth	mm	1998 x 2020 x 795		1998 x 2510 x 795		
Unit weight	kg	730	745	940	958	979

MODELS	DHADR DHAUR	1002	1204
Power supply	V/Ph/Hz	400V / 3Ph + N + PE / 50Hz	
Air flow	m ³ /h	21500	24000
COMPRESSOR			
Type	-	Scroll	
Cooling capacity (24□C; 50% RH; external air T 35□C)	kW	94.4	124.7
Power consumption	kW	25.7	33.8
Nominal current	A	44.1	56.8
FLA	A	64	86
LRA	A	221	186
Oil charge	l	4.1	3.25
FINNED EVAPORATOR COIL			
Front surface	m ²	2.3	2.9
Geometry	-	25 x 22	
Rows	Nr.	6	
Type of fins	Type	Hydrophilic	
Fin pitch	mm	2.1	
SHR	-	0.92	0.92
FAN SECTION			
Type of fans	-	Radial - EC	
Power supply	V/Ph/Hz	400V / 3Ph / 50Hz	
Fans	Nr.	2	3
Current consumption	A	6.6	4,9
Power consumption	W	3.9	2,9
AESP	Pa	30	
AESP (max. fan speed)	Pa	226	440
FILTER SECTION			
Filter efficiency	-	G4	
Overall surface	m ²	5.2	6.9
Fire resistance class	-	1	
ELECTRICAL HEATERS			
Total heating capacity	kW	12.8	12.8
Heaters	Nr.	8	8
Material	-	Aluminium	
HOT GAS REHEATING COIL			
Heating capacity	kW	-	-
Front surface	m ²	-	-
HOT WATER REHEATING COIL			
Heating capacity (water 45/40□C)	kW	-	-
Front surface	m ²	-	-
Water flow	m ³ /h	-	-
Water side pressure drop	kPa	-	-
Valve pressure drop	kPa	-	-
HUMIDIFIER			
Capacity	kg/h	8	
Power consumption	kW	6	
DIMENSIONS			
Height x Lenght x Depth	mm	1998x2510x950	1998x3160x950
Unit weight	kg	1013	1390

tab. 11 DX unit (1 compressor) - water condensed - DHZDR - DHZUR

MODELS	DHZDR DHZUR	0201	0251	0281	0311	0401
Power supply	V/Ph/Hz	400V / 3Ph + N + PE / 50Hz				
Air flow	m ³ /h	6800		7280		12950
WATER TEMPERATURE 15°C / 30°C						
Cooling capacity	kW	25.26	26.26	31.10	34.37	47.03
Power consumption	kW	4.26	4.49	5.47	6.41	8.51
Waterflow	[l/h]	1654	1720	2062	2272	3092
Pressure drop	[kPa]	7.7	8.2	11.3	13.5	14.1
COMPRESSOR						
Type	-	Scroll				
Power supply	V/Ph/Hz	400V / 3Ph / 50Hz				
Nominal current	A	8.91	9.41	11.48	13.46	16.42
FLA	A	17		20	29	
LRA	A	86	98	130		135
Oil charge	l	3.25		4.25		3.30
FINNED EVAPORATOR COIL						
Front surface	m ²	0.7		0.9		1.3
Geometry	-	25 x 22	25 x 22	25 x 22	25 x 22	25 x 22
Rows	Nr.	5				4
Type of fins	Type	Hydrophilic				
Fin pitch	mm	2.1				
SHR	-	0.88	0.87	0.84	0.79	0.86
FAN SECTION						
Type of fans	Tipo	Radial - EC				
Fans	Nr.	1				2
Current consumption	A	1.61	2.01			3.07
Power consumption	W	1007	1252			1912
AESP	Pa	30				
AESP (max. fan speed)	Pa	367.5	298.4		382.2	
FILTER SECTION						
Filter efficiency	-	G4				
Overall surface	m ²	1.44			2.92	
Fire resistance class	-	1				
ELECTRICAL HEATERS						
Total heating capacity	kW	6.4				9.6
Heaters	Nr.	4				6
Material	-	Aluminium				
HOT GAS REHEATING COIL						
Heating capacity	kW	16.50	16.70	17.30	-	37.20
Front surface	m ²	0.7		0.9		1.3
HOT WATER REHEATING COIL						
Heating capacity (water 45/40°C)	kW	14.50	14.70	14.90	-	29.60
Front surface	m ²	0.7		0.9		1.3
Water flow	m ³ /h	2494	2528	2563	-	5091
Water side pressure drop	kPa	13.00			42.00	
Valve pressure drop	kPa	14.72	15.13	15.55	-	10.13
HUMIDIFIER						
Capacity	kg/h	9.00	8.83	8.64	8.39	8.78
Power consumption	kW	2.25				6.00
DIMENSIONS						
Height x Length x Depth	mm	1998 x 1010 x 795		1998 x 1270 x 795		1998x1760x796
Unit weight	kg	375	385	490	505	595

tab. 12 DX unit (2 compressors) - water condensed - DHZDR - DHZUR

MODELS	DHZDR DHZUR	0272	0302	0362	0422	0452
Power supply	V/Ph/Hz	400V / 3Ph + N + PE / 50Hz				
Air flow	m ³ /h	12950				
WATER TEMPERATURE 15 □ C / 30 □ C						
Cooling capacity	kW	27.90	34.60	40.60	48.00	50.60
Power consumption	kW	5.42	6.96	7.94	9.52	9.98
Waterflow	[l/h]	1957	2329	2768	3187	3369
Pressure drop	[kPa]	3	4.2	5.6	7.2	7.9
COMPRESSOR						
Type	-	Scroll				
Nominal current	V/Ph/Hz	400V / 3Ph / 50Hz				
Nominal current	A	12.2	16.2	17.4	21.4	22.6
FLA	A	10	13	14	17	
LRA	A	50	66	74	86	98
Oil charge	l	1.36		1.65		3.25
FINNED EVAPORATOR COIL						
Front surface	m ²	1.3				
Geometry	-	25 x 22				
Rows	Nr.	3			4	
Type of fins	Type	Hydrophilic				
Fin pitch	mm	1.8				
SHR	-	1.00	0.99	0.98	0.97	0.98
FAN SECTION						
Type of fans	Tipo	Radial - EC				
Fans	Nr.	2				
Current consumption	A	4.3			4.4	
Power consumption	W	2500			2595	2600
AESP	Pa	30				
AESP (max. fan speed)	Pa	425			355	
FILTER SECTION						
Filter efficiency	-	G4				
Overall surface	m ²	2.92				
Fire resistance class	-	1				
ELECTRICAL HEATERS						
Total heating capacity	kW	9.6				
Heaters	Nr.	3				
Material	-	Aluminium				
HOT GAS REHEATING COIL						
Heating capacity	kW	34.1	33.7		41.6	42.3
Front surface	m ²	1.05				
HOT WATER REHEATING COIL						
Heating capacity (water 45/40 □ C)	kW	39.6	41.0		42.0	
Front surface	m ²	1.05				
Water flow	m ³ /h	4.936	5.021		5.159	
Water side pressure drop	kPa	39.6	41.0		42.0	
Valve pressure drop	kPa	7.69	8.42	9.19	10.13	10.61
HUMIDIFIER						
Capacity	kg/h	8				
Power consumption	kW	6				
DIMENSIONS						
Height x Length x Depth	mm	1998 x 1750 x 795				
Unit weight	kg	565	580	590	605	615

MODELS	DHZDR DHZUR	0532	0592	0602	0692	0762
Power supply	V/Ph/Hz	400V / 3Ph + N + PE / 50Hz				
Air flow	m ³ /h	14150		19415		
WATER TEMPERATURE 15°C / 30°C						
Cooling capacity	kW	59.84	66.19	71.23	79.82	87.59
Power consumption	kW	10.92	12.76	12.82	14.86	16.88
Waterflow	[l/h]	3950	4400	4607	5223	5853
Pressure drop	[kPa]	10.5	12.6	13.7	10.5	12.8
COMPRESSOR						
Type	-	Scroll				
Nominal current	V/Ph/Hz	400V / 3Ph / 50Hz				
Nominal current	A	11.48	13.43	13.45	16.37	16.35
FLA	A	20	29		32	
LRA	A		130		135	
Oil charge	l		3.25		3.30	3.25
FINNED EVAPORATOR COIL						
Front surface	m ²	1.5		1.9		
Geometry	-	25 x 22				
Rows	Nr.	4				
Type of fins	Type	Hydrophilic				
Fin pitch	mm	2.1				
SHR	-	0.79	0.76	0.85	0.80	0.76
FAN SECTION						
Type of fans	Tipo	Radial - EC				
Fans	Nr.	2		3		
Current consumption	A	3.98		4.41		
Power consumption	W	2718		3074		
AESP	Pa	30				
AESP (max. fan speed)	Pa	274.2		363.0		
FILTER SECTION						
Filter efficiency	-	G4				
Overall surface	m ²	4.49				
Fire resistance class	-	1				
ELECTRICAL HEATERS						
Total heating capacity	kW	9.6		12.8		
Heaters	Nr.	6		8		
Material	-	Aluminium				
HOT GAS REHEATING COIL						
Heating capacity	kW	38.60	-	51.30	52.70	53.90
Front surface	m ²	1.5		1.9		
HOT WATER REHEATING COIL						
Heating capacity (water 45/40°C)	kW	31.30	-	44.30	46.00	47.60
Front surface	m ²	1.5		1.9		
Water flow	m ³ /h	5.384	-	7.620	7.912	8.187
Water side pressure drop	kPa	45.00	-	34.00	35.00	39.00
Valve pressure drop	kPa	29.00	-	27.00		
HUMIDIFIER						
Capacity	kg/h	8				
Power consumption	kW	6				
DIMENSIONS						
Height x Length x Depth	mm	1998 x 2020 x 795		1998 x 2510 x 795		
Unit weight	kg	730	745	940	958	979

MODELS	DHZDR DHZUR	1002	1204
Power supply	V/Ph/Hz	400V / 3Ph + N + PE / 50Hz	
Air flow	m ³ /h	21500	24000
WATER TEMPERATURE 15°C / 30°C			
Cooling capacity	kW	107	138.5
Power consumption	kW	23.1	28
Waterflow	[l/h]	7180	9311
Pressure drop	[kPa]	18.4	13.5
COMPRESSOR			
Type	-	Scroll	
Power supply	V/Ph/Hz	400V / 3Ph / 50Hz	
Nominal current	A	46.2	60.2
FLA	A	64	86
LRA	A	221	186
Oil charge	l	4.1	3.25
FINNED EVAPORATOR COIL			
Front surface	m ²	2.3	2.9
Geometry	-	25 x 22	
Rows	Nr.	6	6
Type of fins	Type	Hydrophilic	
Fin pitch	mm	2.1	
SHR	-	0.88	0.83
FAN SECTION			
Type of fans	Tipo	Radial - EC	
Fans	Nr.	2	3
Current consumption	A	6.6	4.9
Power consumption	W	3.9	2.9
AESP	Pa	30	
AESP (max. fan speed)	Pa	226	440
FILTER SECTION			
Filter efficiency	-	G4	
Overall surface	m ²	5.2	5.2
Fire resistance class	-	1	
ELECTRICAL HEATERS			
Total heating capacity	kW	14.8	14.8
Heaters	Nr.	5	5
Material	-	Aluminium	
HOT GAS REHEATING COIL			
Heating capacity	kW	-	-
Front surface	m ²	-	-
HOT WATER REHEATING COIL			
Heating capacity (water 45/40°C)	kW	-	-
Front surface	m ²	-	-
Water flow	m ³ /h	-	-
Water side pressure drop	kPa	-	-
Valve pressure drop	kPa	-	-
HUMIDIFIER			
Capacity	kg/h	8	
Power consumption	kW	6	
DIMENSIONS			
Height x Length x Depth	mm	1998x2510x950	1998x3160x950
Unit weight	kg	1114	1529

tab. 11 DX unit (1 compressor) - water condensed - DHWDR - DHWUR

MODELS	DHWDR DHWUR	0201	0251	0281	0311	0401
Power supply	V/Ph/Hz	400V / 3Ph + N + PE / 50Hz				
Air flow	m ³ /h	6800		7280		12950
WATER TEMPERATURE 40°C / 45°C (30% e.g.)						
Cooling capacity	kW	21.71	22.74	27.13	30.17	40.95
Power consumption	kW	5.84	6.16	7.40	8.66	11.55
Waterflow	[l/h]	5380	5634	6653	7571	9957
Pressure drop	[kPa]	16.9	19.5	16.7	21.1	34.5
COMPRESSOR						
Type	-	Scroll				
Power supply	V/Ph/Hz	400V / 3Ph / 50Hz				
Nominal current	A	8.91	9.41	11.48	13.46	16.42
FLA	A	17		20	29	
LRA	A	86	98	130		135
Oil charge	l	3.25		4.25		3.30
FINNED EVAPORATOR COIL						
Front surface	m ²	0.7		0.9		1.3
Geometry	-	25 x 22	25 x 22	25 x 22	25 x 22	25 x 22
Rows	Nr.	5				4
Type of fins	Type	Hydrophilic				
Fin pitch	mm	2.1				
SHR	-	0.88	0.87	0.84	0.79	0.86
FAN SECTION						
Type of fans	Tipo	Radial - EC				
Fans	Nr.	1			2	
Current consumption	A	1.61	2.01			3.07
Power consumption	W	1007	1252			1912
AESP	Pa	30				
AESP (max. fan speed)	Pa	367.5	298.4			382.2
FILTER SECTION						
Filter efficiency	-	G4				
Overall surface	m ²	1.44			2.92	
Fire resistance class	-	1				
ELECTRICAL HEATERS						
Total heating capacity	kW	6.4			9.6	
Heaters	Nr.	4			6	
Material	-	Aluminium				
HOT GAS REHEATING COIL						
Heating capacity	kW	16.50	16.70	17.30	-	37.20
Front surface	m ²	0.7		0.9		1.3
HOT WATER REHEATING COIL						
Heating capacity (water 45/40°C)	kW	14.50	14.70	14.90	-	29.60
Front surface	m ²	0.7		0.9		1.3
Water flow	m ³ /h	2494	2528	2563	-	5091
Water side pressure drop	kPa	13.00			42.00	
Valve pressure drop	kPa	14.72	15.13	15.55	-	10.13
HUMIDIFIER						
Capacity	kg/h	9.00	8.83	8.64	8.39	8.78
Power consumption	kW	2.25			6.00	
DIMENSIONS						
Height x Length x Depth	mm	1998 x 1010 x 795		1998 x 1270 x 795		1998x1760x796
Unit weight	kg	375	385	490	505	595

tab. 12 DX unit (2 compressors) - water condensed - DHWDR - DHWUR

MODELS	DHWDR DHWUR	0272	0302	0362	0422	0452
Power supply	V/Ph/Hz	400V / 3Ph + N + PE / 50Hz				
Air flow	m ³ /h	12950				
WATER TEMPERATURE 40°C / 45°C (30% e.g.)						
Cooling capacity	kW	23.50	28.90	34.00	39.94	42.12
Power consumption	kW	7.42	9.26	10.70	12.72	13.34
Waterflow	[l/h]	6507	7729	8839	10258	10885
Pressure drop	[kPa]	9.6	13.1	16.6	21.6	24
COMPRESSOR						
Type	-	Scroll				
Nominal current	V/Ph/Hz	400V / 3Ph / 50Hz				
Nominal current	A	12.2	16.2	17.4	21.4	22.6
FLA	A	10	13	14	17	
LRA	A	50	66	74	86	98
Oil charge	l	1.36		1.65		3.25
FINNED EVAPORATOR COIL						
Front surface	m ²	1.3				
Geometry	-	25 x 22				
Rows	Nr.	3			4	
Type of fins	Type	Hydrophilic				
Fin pitch	mm	1.8				
SHR	-	1.00	0.99	0.98	0.97	0.98
FAN SECTION						
Type of fans	Tipo	Radial - EC				
Fans	Nr.	2				
Current consumption	A	4.3			4.4	
Power consumption	W	2500			2595	2600
AESP	Pa	30				
AESP (max. fan speed)	Pa	425			355	
FILTER SECTION						
Filter efficiency	-	G4				
Overall surface	m ²	2.92				
Fire resistance class	-	1				
ELECTRICAL HEATERS						
Total heating capacity	kW	9.6				
Heaters	Nr.	3				
Material	-	Aluminium				
HOT GAS REHEATING COIL						
Heating capacity	kW	34.1	33.7		41.6	42.3
Front surface	m ²	1.05				
HOT WATER REHEATING COIL						
Heating capacity (water 45/40°C)	kW	39.6	41.0		42.0	
Front surface	m ²	1.05				
Water flow	m ³ /h	4.936	5.021		5.159	
Water side pressure drop	kPa	39.6	41.0		42.0	
Valve pressure drop	kPa	7.69	8.42	9.19	10.13	10.61
HUMIDIFIER						
Capacity	kg/h	8				
Power consumption	kW	6				
DIMENSIONS						
Height x Length x Depth	mm	1998 x 1750 x 795				
Unit weight	kg	565	580	590	605	615

MODELS	DHWDR DHWUR	0532	0592	0602	0692	0762
Power supply	V/Ph/Hz	400V / 3Ph + N + PE / 50Hz				
Air flow	m ³ /h	14150		19415		
WATER TEMPERATURE 40°C / 45°C (30% e.g.)						
Cooling capacity	kW	52.32	58.06	62.10	69.85	77.02
Power consumption	kW	14.78	17.28	17.34	20.18	22.98
Waterflow	[l/h]	13160	14452	14986	17118	18978
Pressure drop	[kPa]	16.4	19.4	20.7	26.3	31.6
COMPRESSOR						
Type	-	Scroll				
Nominal current	V/Ph/Hz	400V / 3Ph / 50Hz				
Nominal current	A	11.48	13.43	13.45	16.37	16.35
FLA	A	20	29		32	
LRA	A		130		135	
Oil charge	l		3.25		3.30	3.25
FINNED EVAPORATOR COIL						
Front surface	m ²	1.5		1.9		
Geometry	-	25 x 22				
Rows	Nr.	4				
Type of fins	Type	Hydrophilic				
Fin pitch	mm	2.1				
SHR	-	0.79	0.76	0.85	0.80	0.76
FAN SECTION						
Type of fans	Tipo	Radial - EC				
Fans	Nr.	2		3		
Current consumption	A	3.98		4.41		
Power consumption	W	2718		3074		
AESP	Pa	30				
AESP (max. fan speed)	Pa	274.2		363.0		
FILTER SECTION						
Filter efficiency	-	G4				
Overall surface	m ²	4.49				
Fire resistance class	-	1				
ELECTRICAL HEATERS						
Total heating capacity	kW	9.6		12.8		
Heaters	Nr.	6		8		
Material	-	Aluminium				
HOT GAS REHEATING COIL						
Heating capacity	kW	38.60	-	51.30	52.70	53.90
Front surface	m ²	1.5		1.9		
HOT WATER REHEATING COIL						
Heating capacity (water 45/40°C)	kW	31.30	-	44.30	46.00	47.60
Front surface	m ²	1.5		1.9		
Water flow	m ³ /h	5.384	-	7.620	7.912	8.187
Water side pressure drop	kPa	45.00	-	34.00	35.00	39.00
Valve pressure drop	kPa	29.00	-	27.00		
HUMIDIFIER						
Capacity	kg/h	8				
Power consumption	kW	6				
DIMENSIONS						
Height x Length x Depth	mm	1998 x 2020 x 795		1998 x 2510 x 795		
Unit weight	kg	730	745	940	958	979

MODELS	DHWDR DHWUR	1002	1204
Power supply	V/Ph/Hz	400V / 3Ph + N + PE / 50Hz	
Air flow	m ³ /h	21500	24000
WATER TEMPERATURE 40°C / 45°C (30% e.g.)			
Cooling capacity	kW	92.5	122.2
Power consumption	kW	30.2	36.9
Waterflow	[l/h]	23121	30399
Pressure drop	[kPa]	45.1	73.6
COMPRESSOR			
Type	-	Scroll	
Power supply	V/Ph/Hz	400V / 3Ph / 50Hz	
Nominal current	A	46.2	60.2
FLA	A	64	86
LRA	A	221	186
Oil charge	l	4.1	3.25
FINNED EVAPORATOR COIL			
Front surface	m ²	2.3	2.9
Geometry	-	25 x 22	
Rows	Nr.	6	6
Type of fins	Type	Hydrophilic	
Fin pitch	mm	2.1	
SHR	-	0.88	0.83
FAN SECTION			
Type of fans	Tipo	Radial - EC	
Fans	Nr.	2	3
Current consumption	A	6.6	4.9
Power consumption	W	3.9	2.9
AESP	Pa	30	
AESP (max. fan speed)	Pa	226	440
FILTER SECTION			
Filter efficiency	-	G4	
Overall surface	m ²	5.2	5.2
Fire resistance class	-	1	
ELECTRICAL HEATERS			
Total heating capacity	kW	14.8	14.8
Heaters	Nr.	5	5
Material	-	Aluminium	
HOT GAS REHEATING COIL			
Heating capacity	kW	-	-
Front surface	m ²	-	-
HOT WATER REHEATING COIL			
Heating capacity (water 45/40°C)	kW	-	-
Front surface	m ²	-	-
Water flow	m ³ /h	-	-
Water side pressure drop	kPa	-	-
Valve pressure drop	kPa	-	-
HUMIDIFIER			
Capacity	kg/h	8	
Power consumption	kW	6	
DIMENSIONS			
Height x Length x Depth	mm	1998x2510x950	1998x3160x950
Unit weight	kg	1114	1529

tab. 13 CW unit (nominal air flow) - DHCDR - DHCUR

MODELS	DHCDR	300	380	450	550	400	500
	DHCUR	300	380	450	550	400	500
Power supply	V/Ph/Hz	400V / 3Ph + N + PE / 50Hz					
Tot. cool. capacity (T water 7/12°C; T air 24°C, 50% RH)	kW	28.1	42.5	47.2	56.6	44.6	56.9
Water flow	l/s	4837	7318	8092	9735	7678	9795
Air flow	m ³ /h	7450		9120		14550	
Water side pressure drop	kPa	24.1	25.1	46.5	48.9	32.3	32.6
FINNED EVAPORATOR COIL							
Front surface	m ²	0.9		1.3		1.9	
Geometry	-	25x22					
Rows	Nr.	3	6	4	6	2	3
Type of fins	Type	Hydrophilic					
Fin pitch	mm	1.8					
SHR	-	0.9	0.82	0.8	0.79	0.89	0.88
FAN SECTION							
Type of fans	V/Ph/Hz	400V / 3Ph / 50Hz					
Type of fans	Tipo	Radial - EC					
Fans	Nr.	1			2		
Current consumption	A	1.3	1.6	1.6	1.8	2.8	3
Power consumption	W	0.8	1	1	1.1	1.7	1.9
AESP (standard fan)	Pa	30					
AESP (max. fan speed)	Pa	402	350	228	205	390	3733
FILTER SECTION							
Filter efficiency	-	G4					
Overall surface	m ²	1.7	1.7	2.4	2.4	3.5	3.5
Fire resistance class	-	1					
ELECTRICAL HEATERS							
Total heating capacity	kW	6.4			9.6		
Heaters	Nr.	4			6		
Material	-	Aluminium					
HOT WATER REHEATING COIL							
Heating capacity (T water 45/40°C)	kW	14.5	16.7	20.6	22.2	14.9	25.8
Front surface	m ²	0.5	0.5	0.8	0.8	1.1	1.1
Water flow	m ³ /h	2517	2909	3584	3851	2563	4438
Water side pressure drop	kPa	10.6	13.6	13.5	15.4	13	33
Valve pressure drop	kPa	14.9	20.1	5	2.4	15.5	7.7
HUMIDIFIER							
Power supply	V/Ph/Hz	230V / 1Ph / 50Hz					
Effective capacity	kg/h	8					
Power consumption	kW	6					
SOUND LEVEL							
Sound pressure level	dB(A)	72	74	74	74	74	75
DIMENSIONS							
Height	mm	1998		1998		1998	
Length	mm	1000		1270		1750	
Depth	mm	795		795		795	
Unit weight	kg	310	350	364	370	370	410

MODELS	DHCDR	650	750	890	1090	900	1000
	DHCUR	650	750	890	1090	900	1000
Power supply	V/Ph/Hz	400V / 3Ph + N + PE / 50Hz					
Tot. cool. capacity (T water 7/12°C; T air 24°C, 50% RH)	kW	74.1	85.6	90.6	110.7	87.8	112
Water flow	l/s	12754	14733	15598	18442	15114	19275
Air flow	m ³ /h	14550		18020		21400	
Water side pressure drop	kPa	61.5	65.2	71.5	75.1	37.4	69
FINNED EVAPORATOR COIL							
Front surface	m ²	1.9		2.1		2.8	
Geometry	-	25x22					
Rows	Nr.	4	6	4	6	3	4
Type of fins	Type	Hydrophilic					
Fin pitch	mm	1.8					
SHR	-	0.82	0.8	0.81	0.77	0.87	0.8
FAN SECTION							
Type of fans	V/Ph/Hz	400V / 3Ph / 50Hz					
Type of fans	Tipo	Radial - EC					
Fans	Nr.	2			3		
Current consumption	A	3.2	3.6	4.5	4	4.7	5
Power consumption	W	2	2.2	2.8	3.1	2.9	3.1
AESP (standard fan)	Pa	30					
AESP (max. fan speed)	Pa	356	321	167	134	366	349
FILTER SECTION							
Filter efficiency	-	G4					
Overall surface	m ²	3.5	3.5	4.6	4.6	5.2	5.2
Fire resistance class	-	1					
ELECTRICAL HEATERS							
Total heating capacity	kW	9.6					
Heaters	Nr.	6					
Material	-	Aluminium					
HOT WATER REHEATING COIL							
Heating capacity (T water 45/40°C)	kW	33.7	35.3	39.1	41.9	50.2	53.8
Front surface	m ²	1.1	1.1	1.3	1.3	1.7	1.7
Water flow	m ³ /h	5862	6144	6795	7278	8634	9257
Water side pressure drop	kPa	41.6	45.1	59.4	67	42.7	48.1
Valve pressure drop	kPa	13.4	14.7	7.4	8.5	11.9	13.7
HUMIDIFIER							
Power supply	V/Ph/Hz	230V / 1Ph / 50Hz					
Effective capacity	kg/h	8					
Power consumption	kW	6					
SOUND LEVEL							
Sound pressure level	dB(A)	76	76	77	77	77	78
DIMENSIONS							
Height	mm	1998		1998		1998	
Length	mm	1750		2020		2500	
Depth	mm	795		795		795	
Unit weight	kg	430	475	490	510	490	510

	DHCDR	1200	1500	1800	2100
MODELS	DHCUR	1200	-	-	-
Power supply	V/Ph/Hz	400V / 3Ph + N + PE / 50Hz			
Tot. cool. capacity (T water 7/12°C; T air 24°C, 50% RH)	kW	126.9	151.4	167	236.1
Water flow	l/s	21838	26053	28736	40628
Air flow	m ³ /h	21400	26200		36120
Water side pressure drop	kPa	112	65.7	91	193.6
FINNED EVAPORATOR COIL					
Front surface	m ²	2.7	5.4		7
Geometry	-		25x22		
Rows	Nr.	6	4	6	6
Type of fins	Type		Hydrophilic		
Fin pitch	mm		1.8		
SHR	-	0.79	0.85	0.78	0.76
FAN SECTION					
Type of fans	V/Ph/Hz	400V / 3Ph / 50Hz			
Type of fans	Tipo	Radial - EC			
Fans	Nr.	3	2		3
Current consumption	A	5.6	6.2	6.5	10.4
Power consumption	W	3.5	3.9	4.1	6.5
AESP (standard fan)	Pa		30		
AESP (max. fan speed)	Pa	314	99	85	142
FILTER SECTION					
Filter efficiency	-		G4		
Overall surface	m ²	5.2	5.2	5.2	6.9
Fire resistance class	-		1		
ELECTRICAL HEATERS					
Total heating capacity	kW		9.6		
Heaters	Nr.		6		
Material	-		Aluminium		
HOT WATER REHEATING COIL					
Heating capacity (T water 45/40°C)	kW	54.7	-	-	-
Front surface	m ²	1.7	-	-	-
Water flow	m ³ /h	9516	-	-	-
Water side pressure drop	kPa	38.9	-	-	-
Valve pressure drop	kPa	14.5	-	-	-
HUMIDIFIER					
Power supply	V/Ph/Hz	230V / 1Ph / 50Hz			
Effective capacity	kg/h		8		
Power consumption	kW		6		
SOUND LEVEL					
Sound pressure level	dB(A)	79	85	86	88
DIMENSIONS					
Height	mm	1998	1998		1998
Length	mm	2500	2500		3160
Depth	mm	795	950		950
Unit weight	kg	530	720	753	785

www.lennox europe.com

SALES OFFICES :

BELGIUM AND LUXEMBOURG

☎ + 32 3 633 3045

RUSSIA

☎ +7 495 626 56 53

FRANCE

☎ +33 1 64 76 23 23

SPAIN

☎ +34 902 533 920

GERMANY

☎ +49 (0) 40 589 6235 0

UKRAINE

☎ +380 44 461 87 79

ITALY

☎ + 39 02 495 26 200

UNITED KINGDOM AND IRELAND

☎ +44 1604 669 100

NETHERLANDS

☎ + 31 332 471 800

POLAND

☎ +48 22 58 48 610

OTHER COUNTRIES :

PORTUGAL

☎ +351 229 066 050

LENNOX DISTRIBUTION

☎ +33 4 72 23 20 00

