



Serie	THND-U-X
Model	045 - 073

Drawing code	HF620C0696	Controller	PC03
--------------	------------	------------	------

Power supply	230V/1~/50Hz + N	-
Auxiliary supply	24VAC	-

Created by	N.C.1	Revision by	N.C.1	Index	D
Date	30/08/07	On	27/10/2009		

Max power (kW)	SEE TABLE ON PAGE 2
FLA (A)	SEE TABLE ON PAGE 2
RLA (A)	SEE TABLE ON PAGE 2

Main protection	SEE TABLE ON PAGE 2
-----------------	---------------------

A	1	2		3	4	5	6		7	8	A
	MODEL	POWER SUPPLY	MAX ABSORBED POWER (kW)	MAX ABSORBED CURENT (A)	RLA (A)	MAIN SUGGEST PROTECTION gG FUSE TYPE	MIN SUGGEST CROSS SECTION LINE (mm ²) VS MAX LENGTH (m) AIR TEMPERATURE 30°C - MULTICORE CABLE - CABLE INSIDE TUBE ON AIR				
							PVC ISULATED		EPR (G7-G10) ISULATED		
							CABLE WORKING TEMPERATURE 70°C	MAX LENGTH VOLTAGE DROP<4%	CABLE WORKING TEMPERATURE 90°C	MAX LENGTH VOLTAGE DROP<4%	
	045 R 407	LINE	2,4	13,0	36	16	2,5	48	1,5	29	
	045 R 134	LINE	3,1	16.3	62	20	4	61	2,5	38	
B	056 R 407	LINE	2,9	15,4	48	20	4	65	2,5	40	
	056 R 134	LINE	3,4	17,9	77	25	6	83	4	56	
	073 R 407	LINE	3,8	19,6	64	25	6	76	4	51	
	073 R 134	LINE	4,9	25,6	117	32	6	58	6	58	
C	073 R 410	LINE	5,3	26,4	117	32	6	56	6	56	C

D											D
E											E

F	B	REVISIONE GENERALE	04/03/2008	N.C.1	DATE	30/08/07					HF620C0696		SHEET	2 OF	21
	C	COLLEGAMENTO VENTILATORE	16/06/2008	N.C.1	DRAW.	N.C.1									
	D	REVISIONE GENERALE	27/10/2009	N.C.1	CHECK	F.F.1									
	REV.	MODIFICATIONS	DATE	SIGN.	APPR.	M.M.							CONTINUE	3	
	1	2	3	4	5	6	7	8							

POWER SUPPLY
230V 1~ 50Hz + N

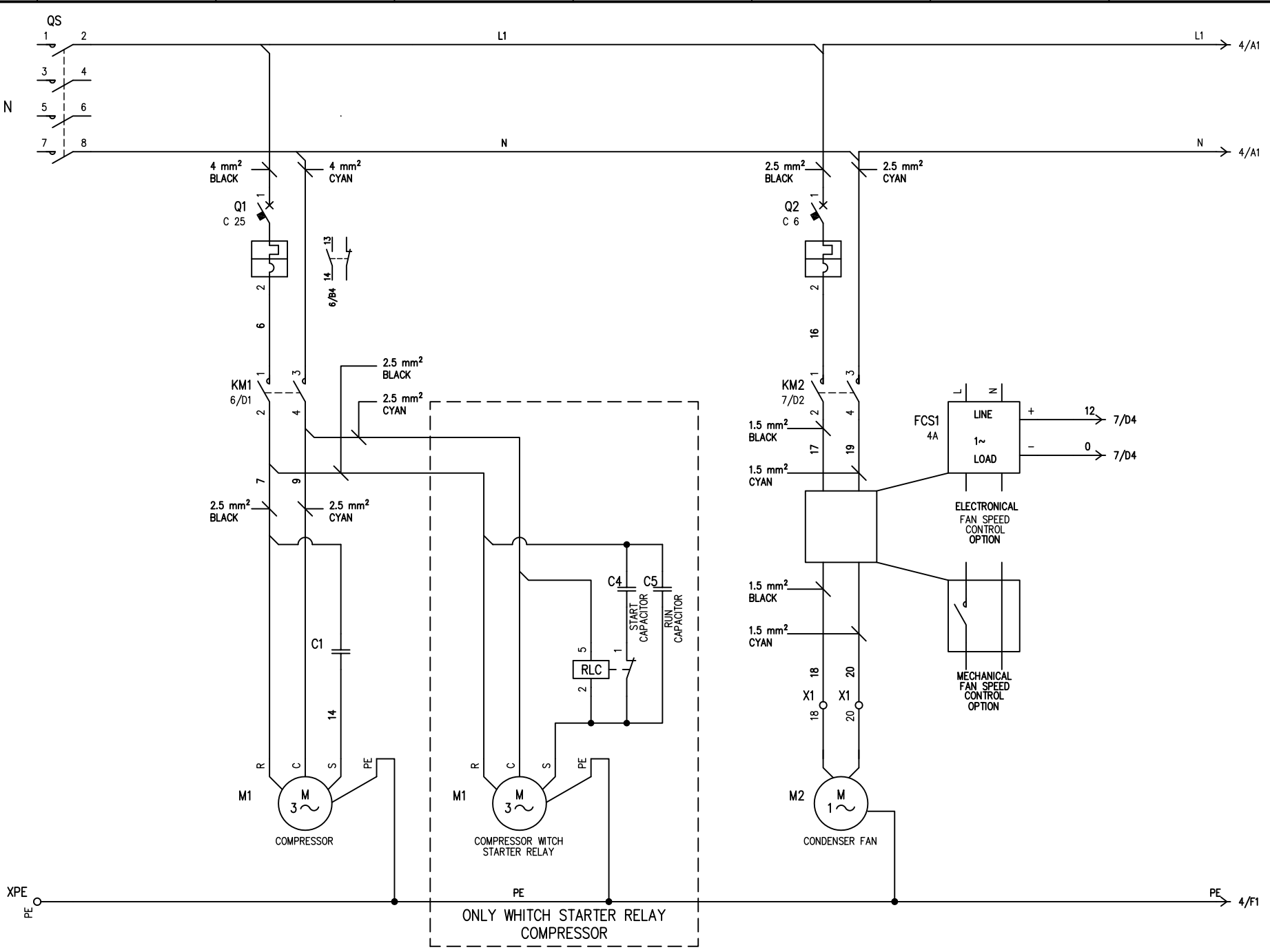

ONLY WHITCH STARTER RELAY
COMPRESSOR

B	REVISIONE GENERALE	04/03/2008	N.C.1	DATE	30/08/07
C	COLLEGAMENTO VENTILATORE	16/06/2008	N.C.1	DRAW.	N.C.1
D	REVISIONE GENERALE	27/10/2009	N.C.1	CHECK	F.F.1
REV.	MODIFICATIONS	DATE	SIGN.	APPR.	M.M.



HF620C0696

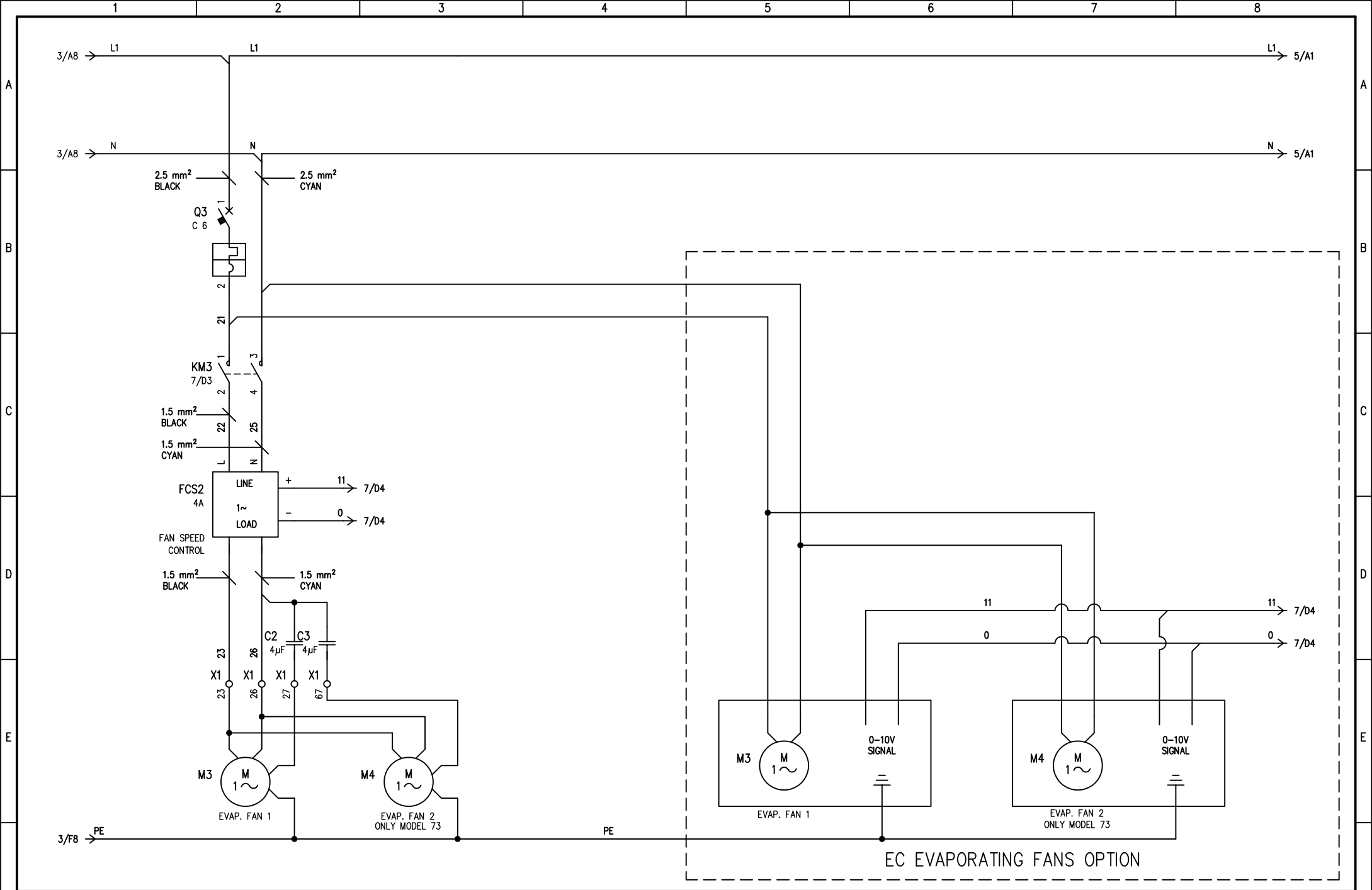

B	REVISIONE GENERALE	04/03/2008	N.C.1	DATE	30/08/07
C	COLLEGAMENTO VENTILATORE	16/06/2008	N.C.1	DRAW.	N.C.1
D	REVISIONE GENERALE	27/10/2009	N.C.1	CHECK	F.F.1
REV.	MODIFICATIONS	DATE	SIGN.	APPR.	M.M.



HF620C0696

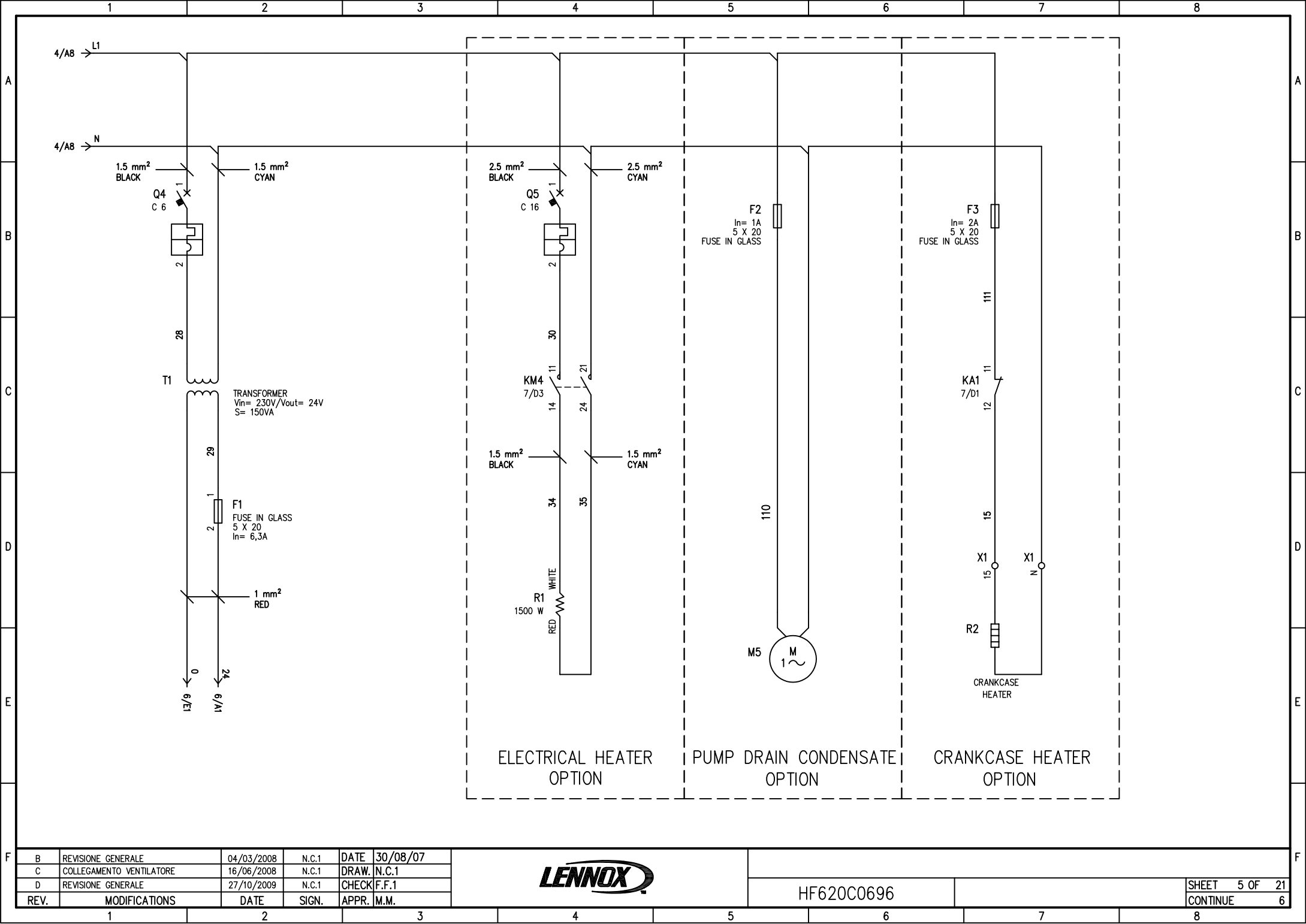

B	REVISIONE GENERALE	04/03/2008	N.C.1	DATE	30/08/07
C	COLLEGAMENTO VENTILATORE	16/06/2008	N.C.1	DRAW.	N.C.1
D	REVISIONE GENERALE	27/10/2009	N.C.1	CHECK	F.F.1
REV.	MODIFICATIONS	DATE	SIGN.	APPR.	M.M.



HF620C0696

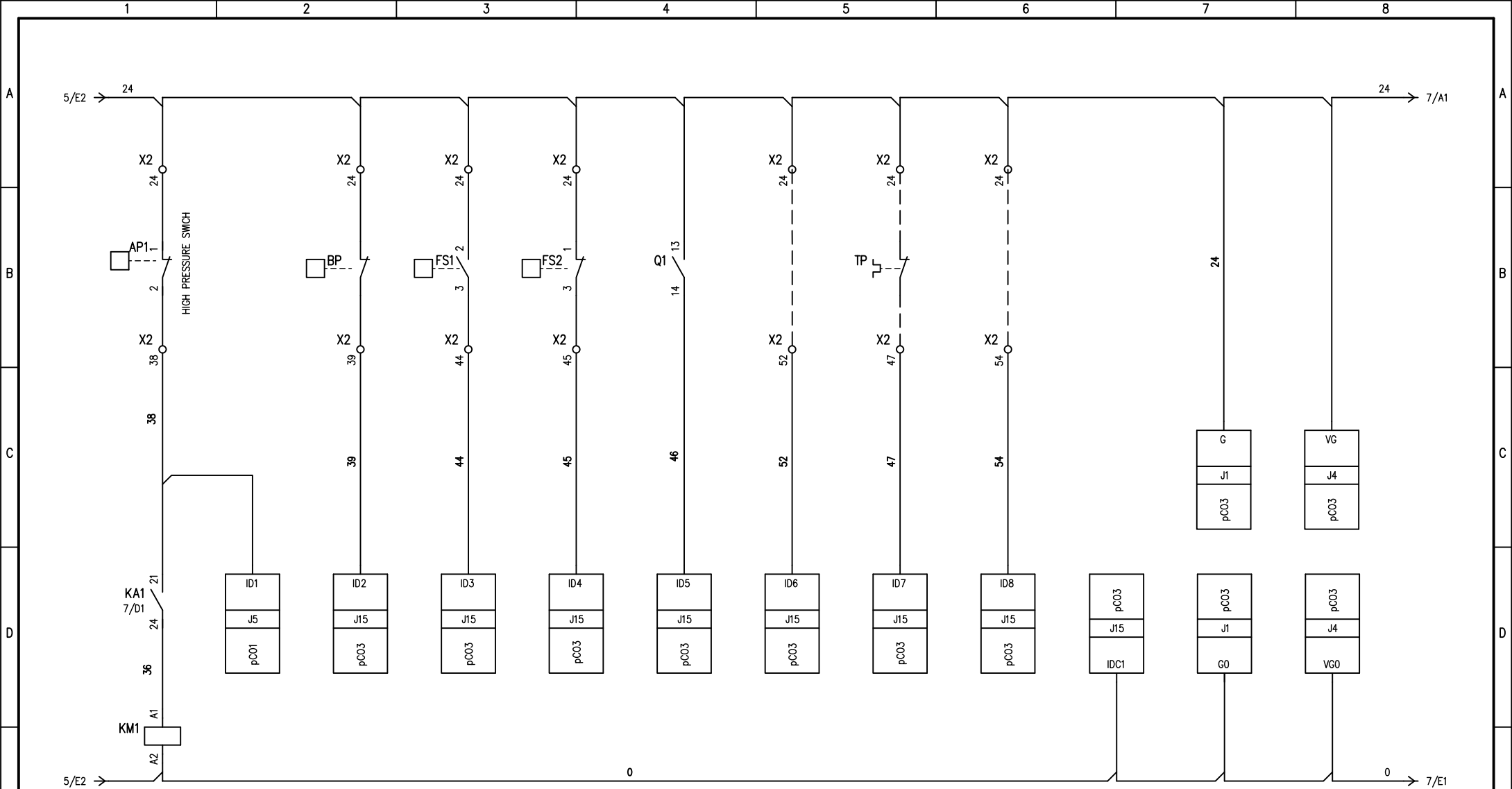

COMPRESSOR ON-OFF HIGH PRESSURE ALARM LOW PRESSURE SWITCH AIR FLOW SWITCH DIRTY FILTER SWITCH COMPRESSOR THERMAL ALARM HUMAN CONFORT SWITCH OR FIRE ALARM OR FLOODING ALARM HEATER'S THERMOSTAT PROTECTION REMOTE ON-OFF

B	REVISIONE GENERALE	04/03/2008	N.C.1	DATE	30/08/07
C	COLLEGAMENTO VENTILATORE	16/06/2008	N.C.1	DRAW.	N.C.1
D	REVISIONE GENERALE	27/10/2009	N.C.1	CHECK	F.F.1
REV.	MODIFICATIONS	DATE	SIGN.	APPR.	M.M.



HF620C0696

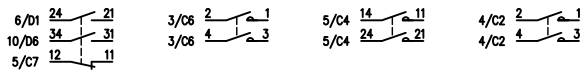
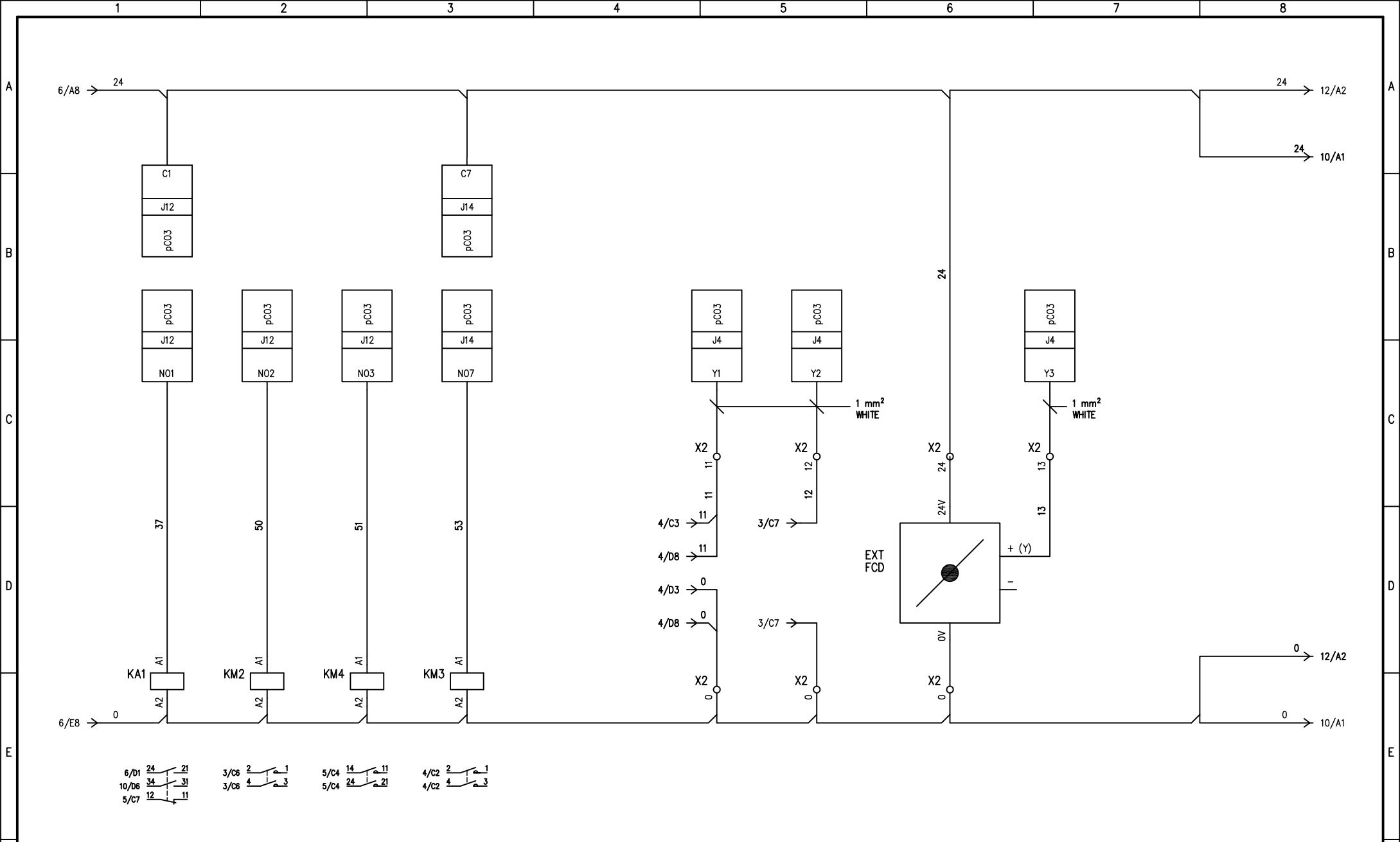

ON-OFF COMPRESSOR CONDENSER FAN ON-OFF HEATER ON-OFF (OPTION) EVAPORATOR FAN ON-OFF EVAPORATOR FAN SPEED SIGNAL (0-10V) CONDENSER FAN SPEED SIGNAL (0-10V) FREECOOLING DAMPER (OPTION) FREECOOLING SIGNAL (0-10V)

B	REVISIONE GENERALE	04/03/2008	N.C.1	DATE	30/08/07
C	COLLEGAMENTO VENTILATORE	16/06/2008	N.C.1	DRAW.	N.C.1
D	REVISIONE GENERALE	27/10/2009	N.C.1	CHECK	F.F.1
REV.	MODIFICATIONS	DATE	SIGN.	APPR.	M.M.



HF620C0696

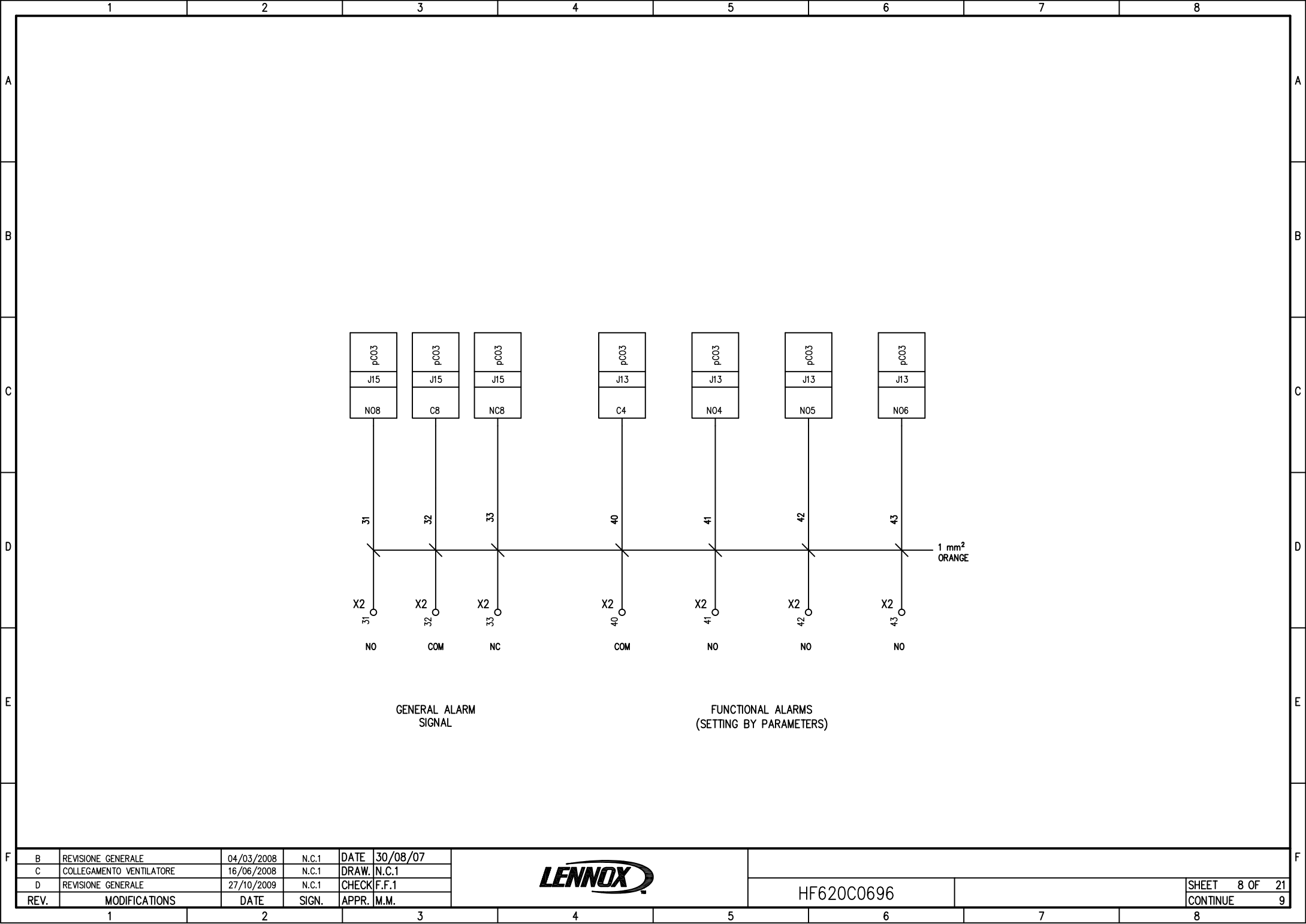

B	REVISIONE GENERALE	04/03/2008	N.C.1	DATE	30/08/07
C	COLLEGAMENTO VENTILATORE	16/06/2008	N.C.1	DRAW.	N.C.1
D	REVISIONE GENERALE	27/10/2009	N.C.1	CHECK	F.F.1
REV.	MODIFICATIONS	DATE	SIGN.	APPR.	M.M.



HF620C0696

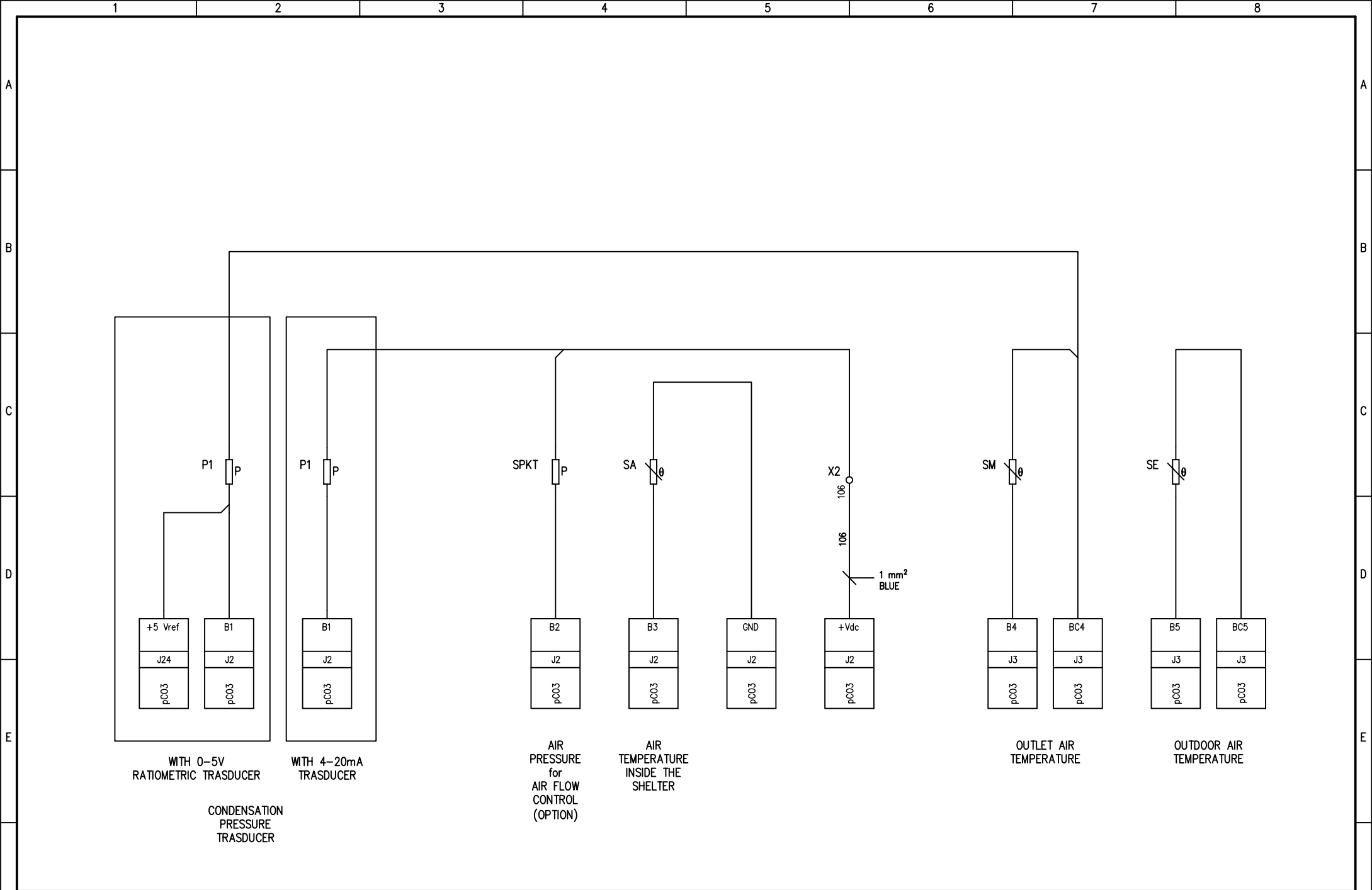

B	REVISIONE GENERALE	04/03/2008	N.C.1	DATE	30/08/07
C	COLLEGAMENTO VENTILATORE	16/06/2008	N.C.1	DRAW.	N.C.1
D	REVISIONE GENERALE	27/10/2009	N.C.1	CHECK	F.F.1
REV.	MODIFICATIONS	DATE	SIGN.	APPR.	M.M.

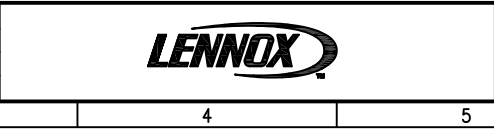

HF620C0696		SHEET 9 OF 21
		CONTINUE 10

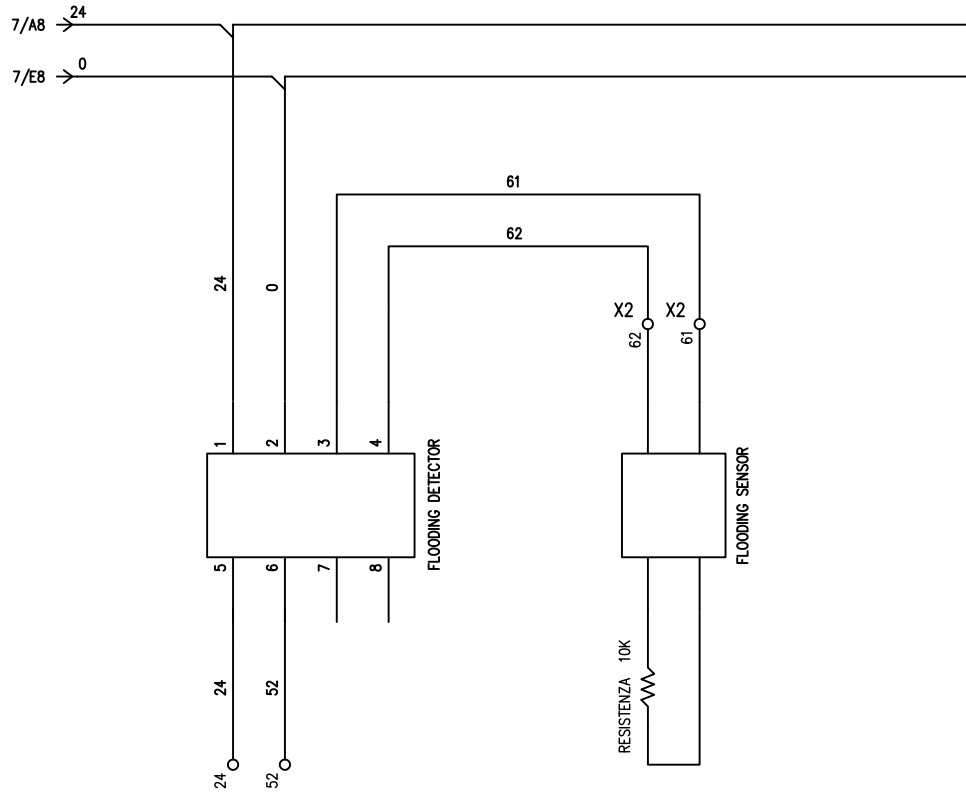

KIT FLOODING DETECTOR OPTION

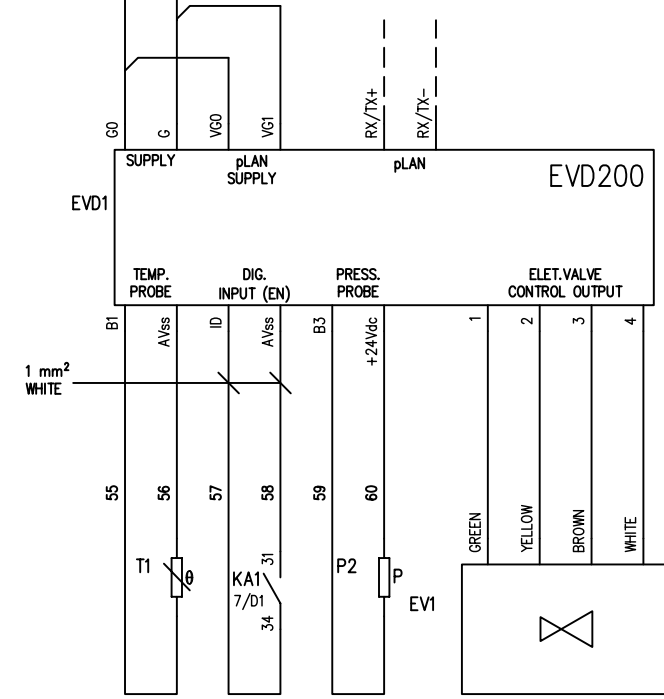

ELECTRONIC EXPANSION VALVE OPTION

B	REVISIONE GENERALE	04/03/2008	N.C.1	DATE	30/08/07
C	COLLEGAMENTO VENTILATORE	16/06/2008	N.C.1	DRAW.	N.C.1
D	REVISIONE GENERALE	27/10/2009	N.C.1	CHECK	F.F.1
REV.	MODIFICATIONS	DATE	SIGN.	APPR.	M.M.



HF620C0696

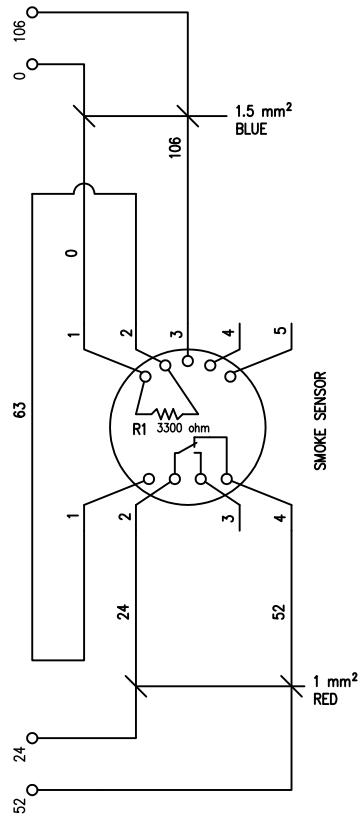

SMOKE SENSOR OPTION

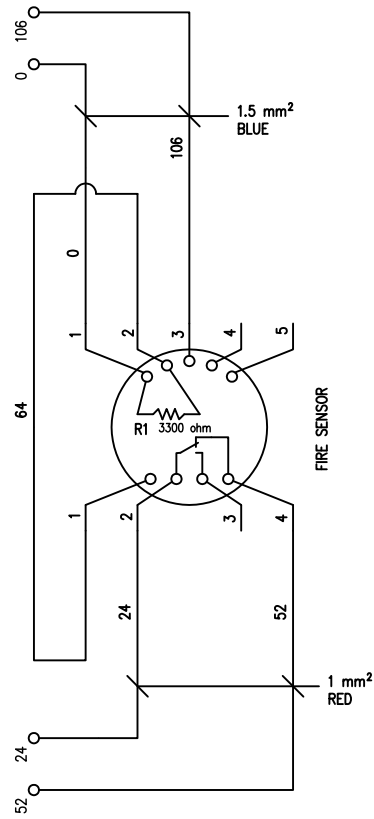

FIRE SENSOR OPTION

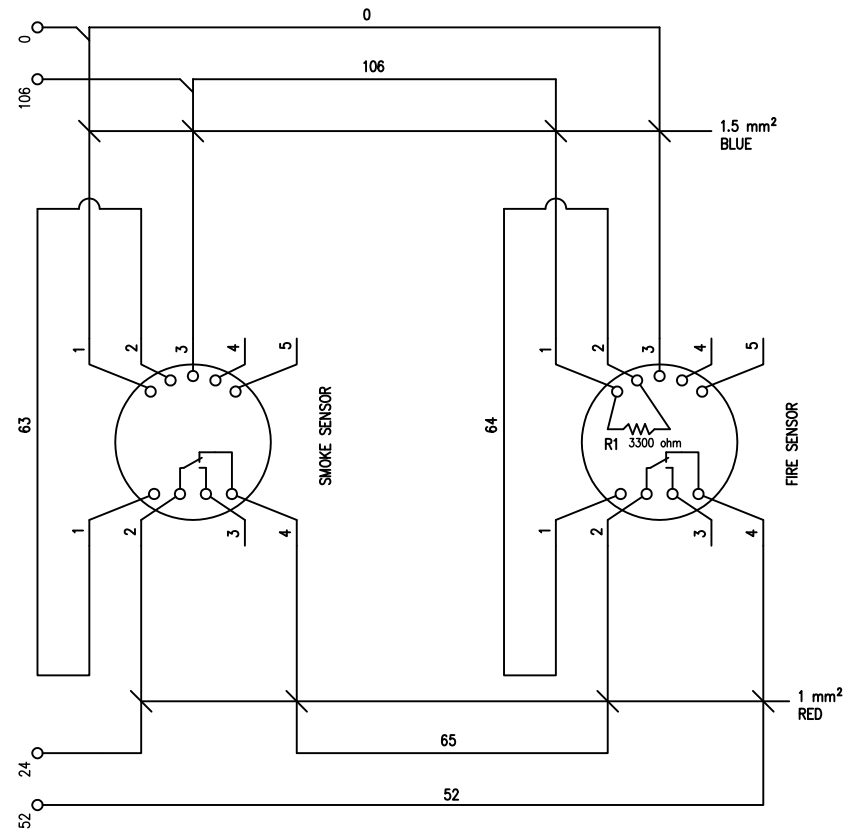

SMOKE/FIRE SENSOR OPTION

B	REVISIONE GENERALE	04/03/2008	N.C.1	DATE	30/08/07
C	COLLEGAMENTO VENTILATORE	16/06/2008	N.C.1	DRAW.	N.C.1
D	REVISIONE GENERALE	27/10/2009	N.C.1	CHECK	F.F.1
REV.	MODIFICATIONS	DATE	SIGN.	APPR.	M.M.



HF620C0696

pLAN CONNECTION

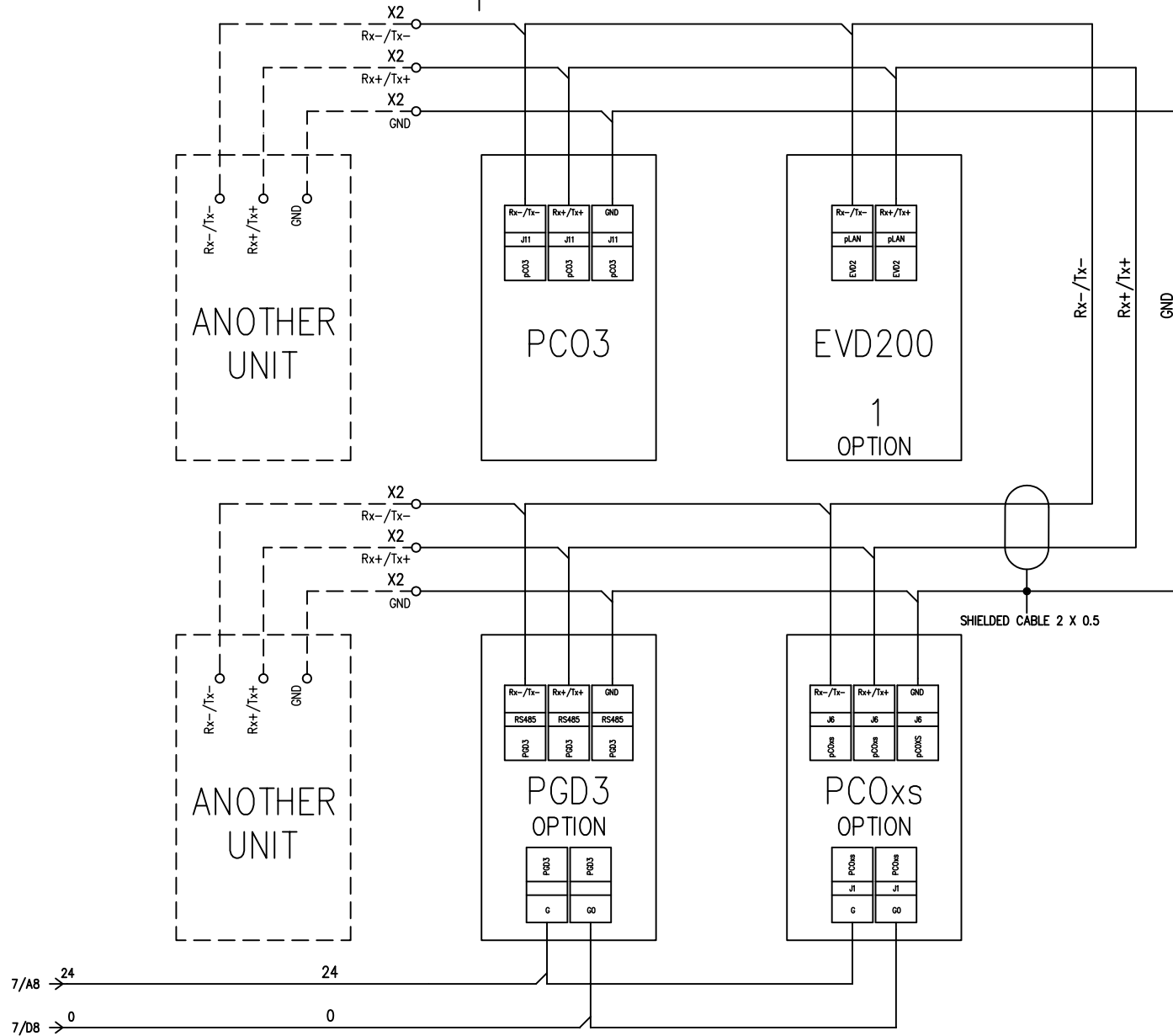

B	REVISIONE GENERALE	04/03/2008	N.C.1	DATE	30/08/07
C	COLLEGAMENTO VENTILATORE	16/06/2008	N.C.1	DRAW.	N.C.1
D	REVISIONE GENERALE	27/10/2009	N.C.1	CHECK	F.F.1
REV.	MODIFICATIONS	DATE	SIGN.	APPR.	M.M.



HF620C0696

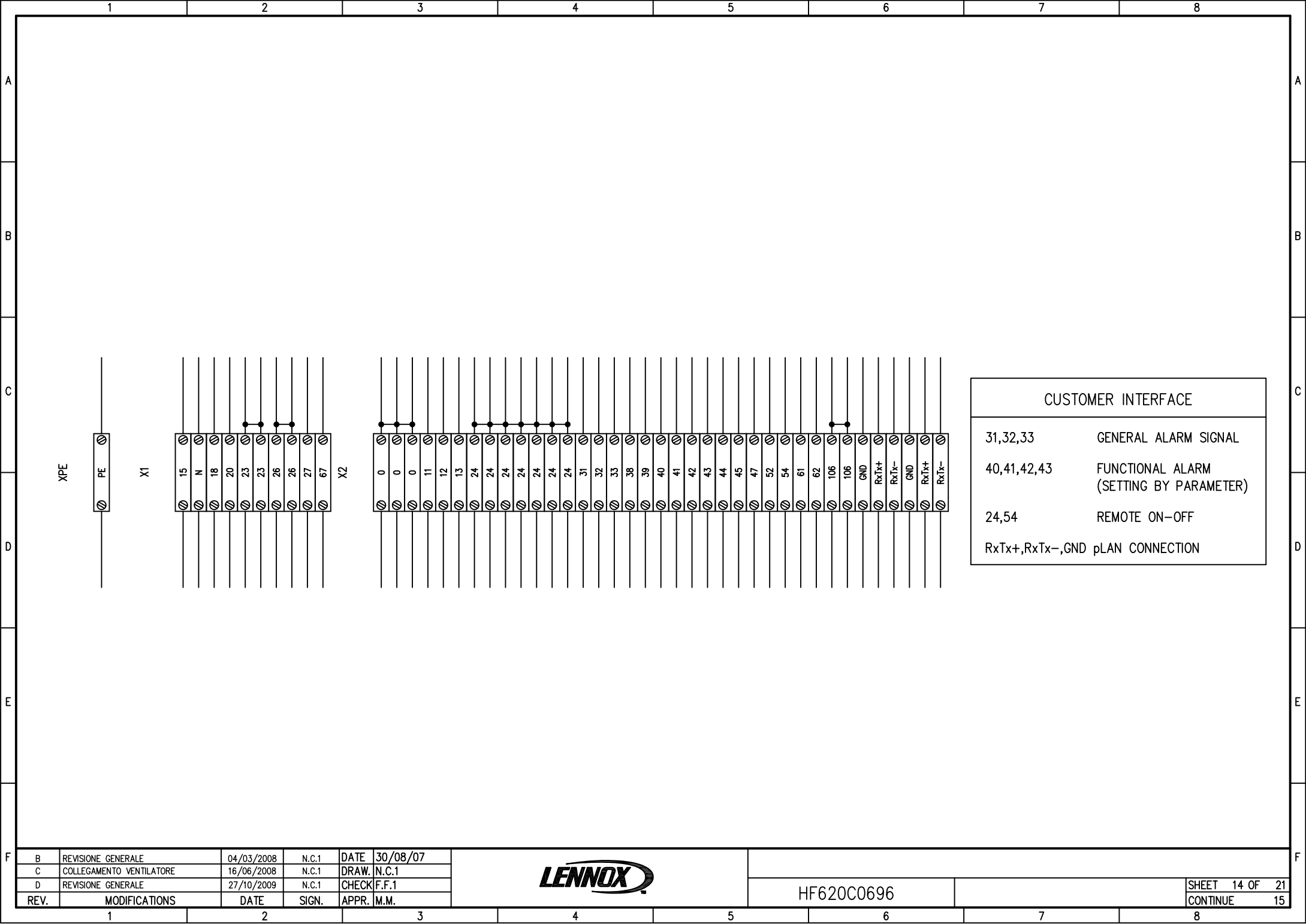

CUSTOMER INTERFACE	
31,32,33	GENERAL ALARM SIGNAL
40,41,42,43	FUNCTIONAL ALARM (SETTING BY PARAMETER)
24,54	REMOTE ON-OFF
RxTx+, RxTx-, GND	pLAN CONNECTION

B	REVISIONE GENERALE	04/03/2008	N.C.1	DATE	30/08/07
C	COLLEGAMENTO VENTILATORE	16/06/2008	N.C.1	DRAW.	N.C.1
D	REVISIONE GENERALE	27/10/2009	N.C.1	CHECK	F.F.1
REV.	MODIFICATIONS	DATE	SIGN.	APPR.	M.M.



HF620C0696

LA LUNGHEZZA DEI CAVI E' RIFERITA ALL'ESTERNO DEL QUADRO

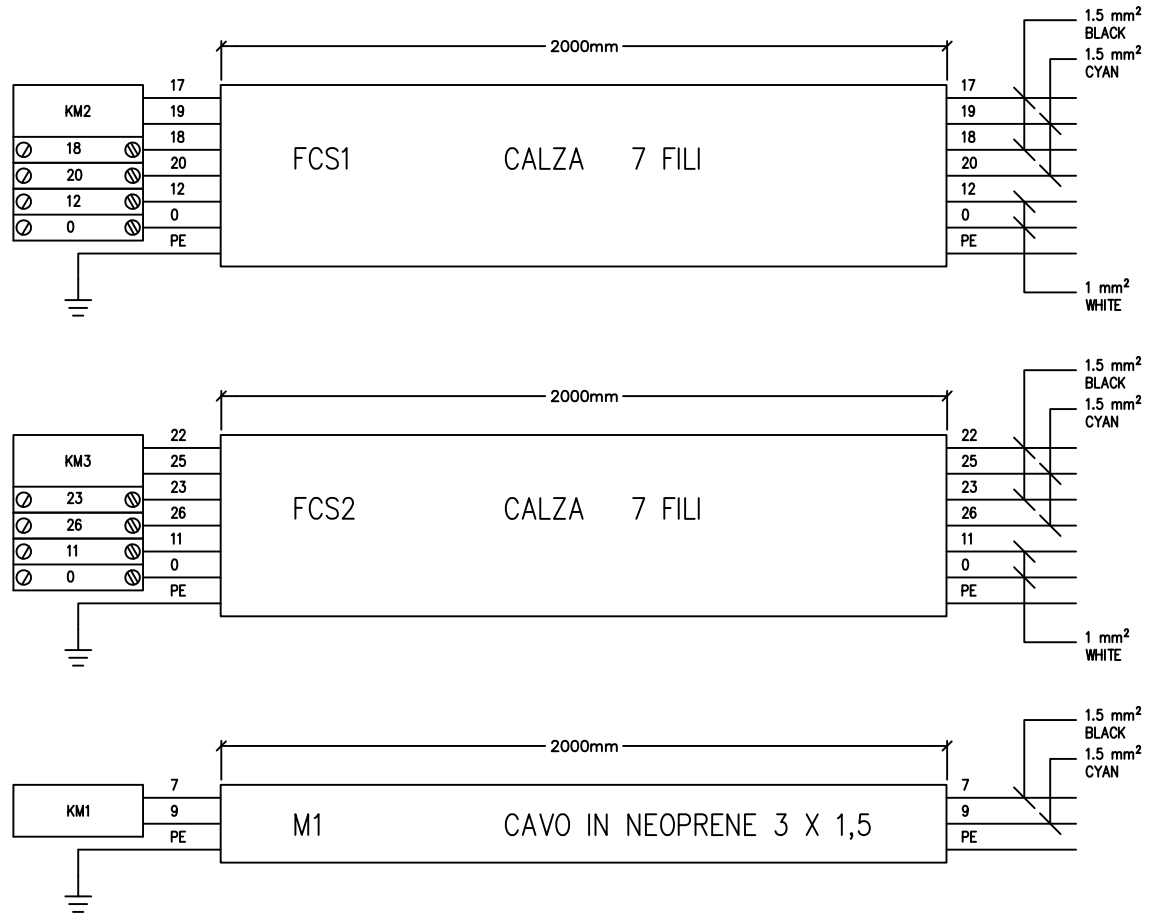

B	REVISIONE GENERALE	04/03/2008	N.C.1	DATE	30/08/07
C	COLLEGAMENTO VENTILATORE	16/06/2008	N.C.1	DRAW.	N.C.1
D	REVISIONE GENERALE	27/10/2009	N.C.1	CHECK	F.F.1
REV.	MODIFICATIONS	DATE	SIGN.	APPR.	I.M.M.



HF620C0696

1

2

3

4

5

6

7

8

A

A

LAYOUT PIASTRA DI FONDO

715

B

B

C

C

330

D

D

E

E

F

F

B	REVISIONE GENERALE	04/03/2008	N.C.1	DATE	30/08/07
C	COLLEGAMENTO VENTILATORE	16/06/2008	N.C.1	DRAW.	N.C.1
D	REVISIONE GENERALE	27/10/2009	N.C.1	CHECK	F.F.1
REV.	MODIFICATIONS	DATE	SIGN.	APPR.	M.M.



HF620C0696

SHEET 16 OF 21
CONTINUE 17

1

2

3

4

5

6

7

8

LAYOUT GUIDE DIN

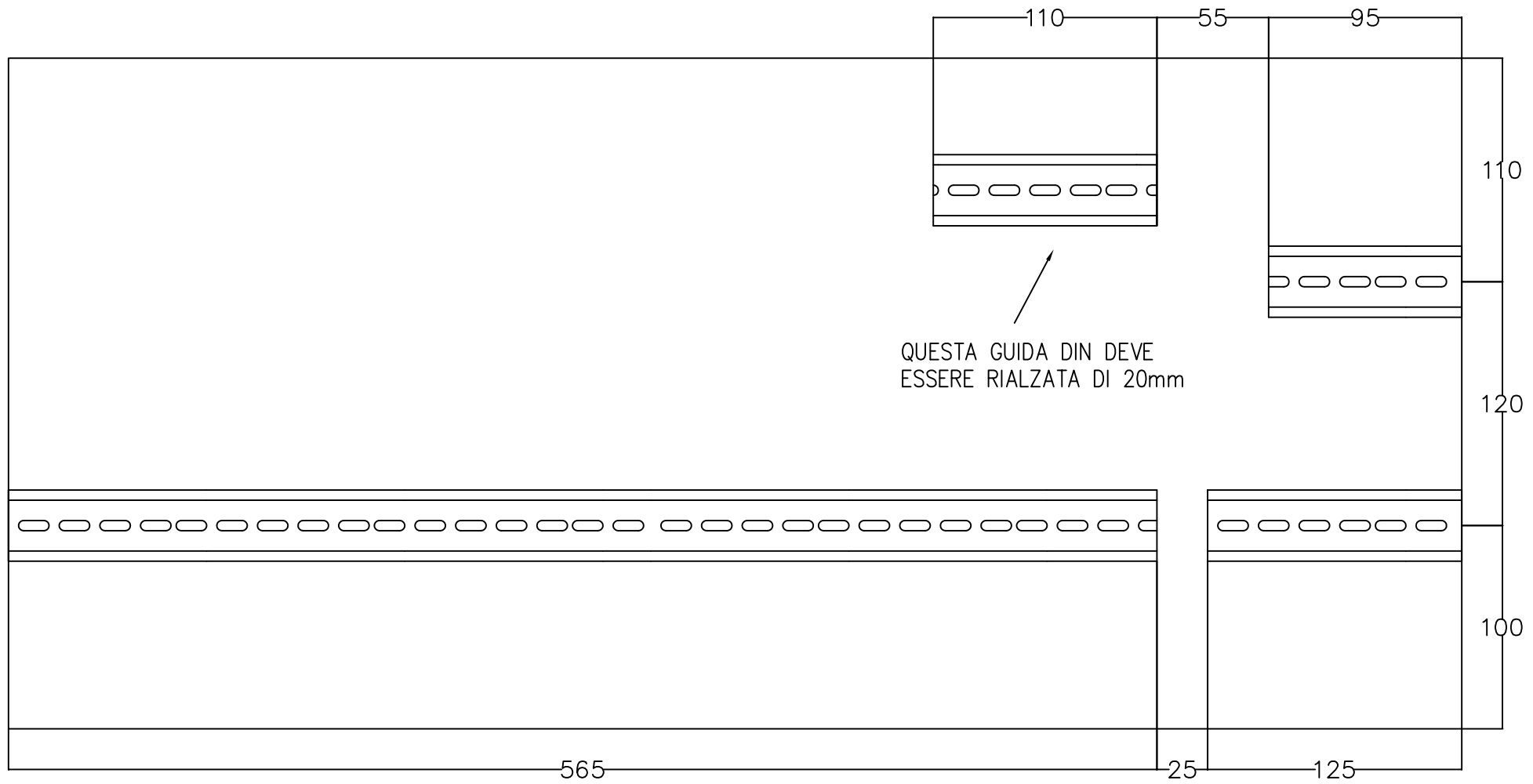

B	REVISIONE GENERALE	04/03/2008	N.C.1	DATE	30/08/07
C	COLLEGAMENTO VENTILATORE	16/06/2008	N.C.1	DRAW.	N.C.1
D	REVISIONE GENERALE	27/10/2009	N.C.1	CHECK	F.F.1
REV.	MODIFICATIONS	DATE	SIGN.	APPR.	M.M.



HF620C0696

1 2 3 4 5 6 7 8

A
B
C
D
E
F

LAYOUT CANALINE

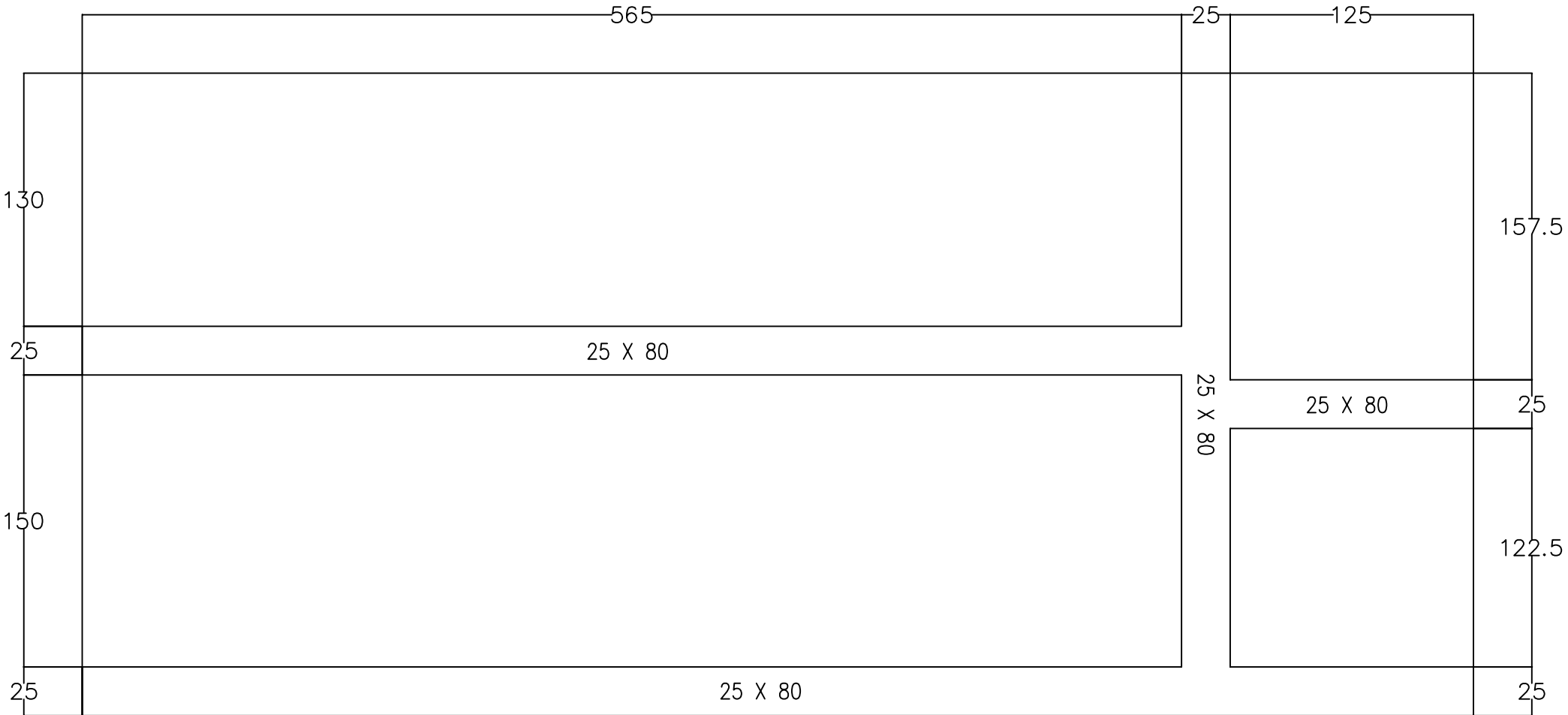

B	REVISIONE GENERALE	04/03/2008	N.C.1	DATE	30/08/07
C	COLLEGAMENTO VENTILATORE	16/06/2008	N.C.1	DRAW.	N.C.1
D	REVISIONE GENERALE	27/10/2009	N.C.1	CHECK	F.F.1
REV.	MODIFICATIONS	DATE	SIGN.	APPR.	M.M.



HF620C0696

1 2 3 4 5 6 7 8

LAYOUT COMPONENTI

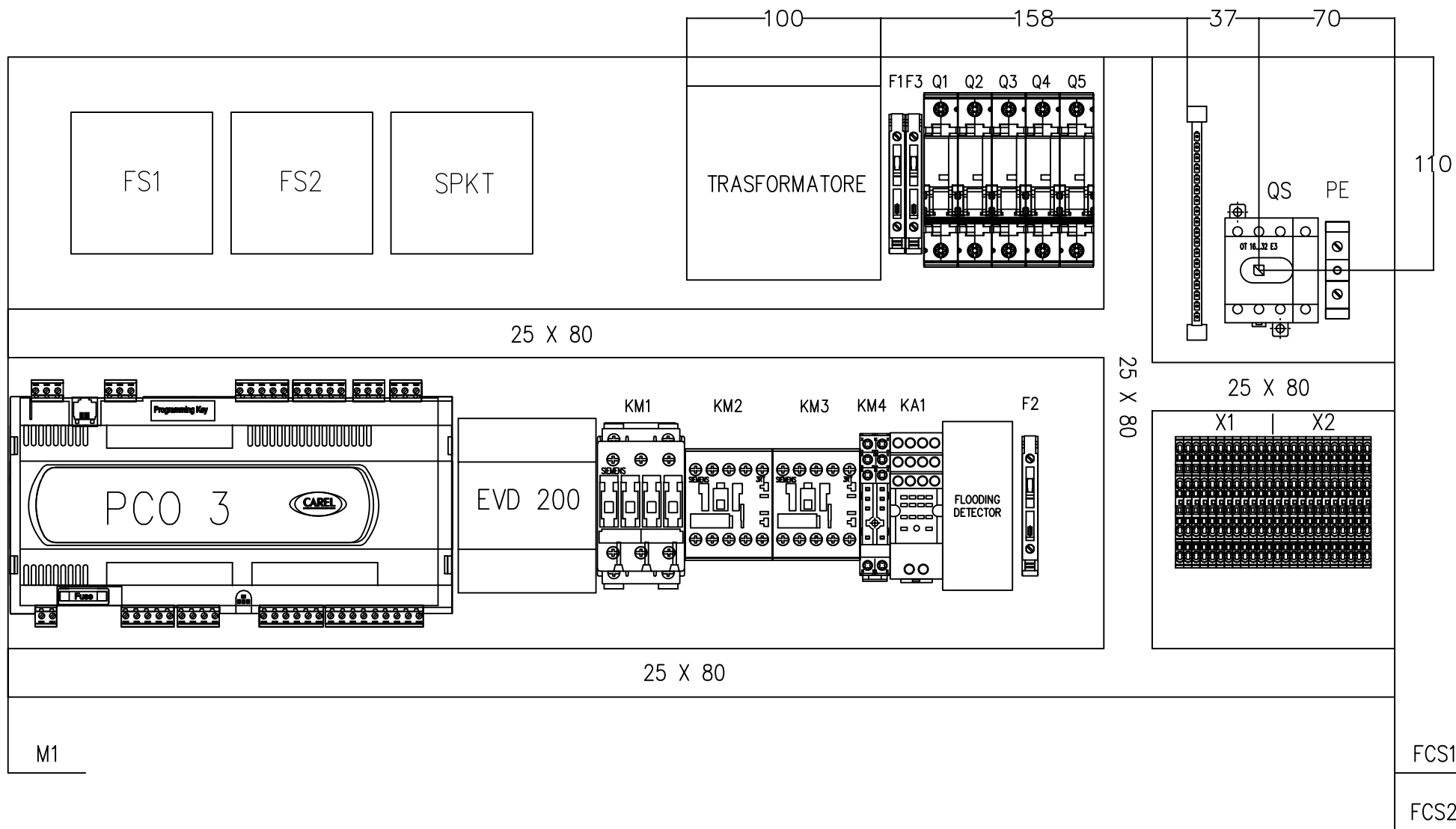

B	REVISIONE GENERALE	04/03/2008	N.C.1	DATE	30/08/07
C	COLLEGAMENTO VENTILATORE	16/06/2008	N.C.1	DRAW.	N.C.1
D	REVISIONE GENERALE	27/10/2009	N.C.1	CHECK	F.F.1
REV.	MODIFICATIONS	DATE	SIGN.	APPR.	M.M.



HF620C0696

	1	2	3	4	5	6	7	8
A	X1, X2	MORSETTIERA	PHOENIX	3031157	MORSETTO A MOLLA STTB 1,5	24	PCE	
	XPE	MORSETTIERA	PHOENIX	3003923	MORSETTO DI TERRA USLKG 10 N	1	PCE	
		PIASTRA DI FONDO	HIREF	HF17000386	PIASTRA DI FONDO	1	PCE	
		BARRA DI TERRA			BARRA DI TERRA	1	PCE	



B	REVISIONE GENERALE	04/03/2008	N.C.1	DATE	30/08/07		HF620C0696	SHEET 21 OF 21 CONTINUE
C	COLLEGAMENTO VENTILATORE	16/06/2008	N.C.1	DRAW.	N.C.1			
D	REVISIONE GENERALE	27/10/2009	N.C.1	CHECK	F.F.1			
REV.	MODIFICATIONS	DATE	SIGN.	APPR.	M.M.			