

DETAIL A
ECHELLE 1/5

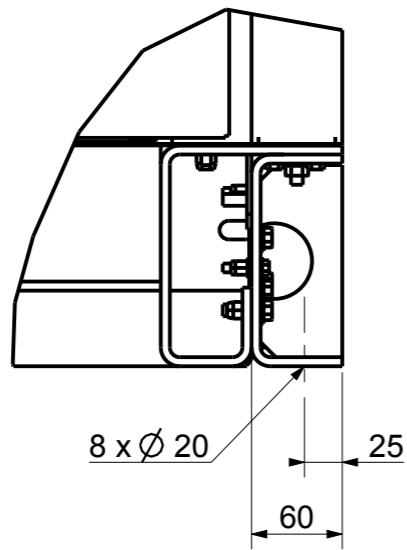

In1 = Chilled water inlet without hydraulic module Ø 6" victaulic
 In2 = Chilled water inlet with hydraulic module Ø 6" victaulic
 Out1 = Chilled water outlet without hydraulic module Ø 6" victaulic
 Out2 = Chilled water outlet with hydraulic module Ø 6" victaulic

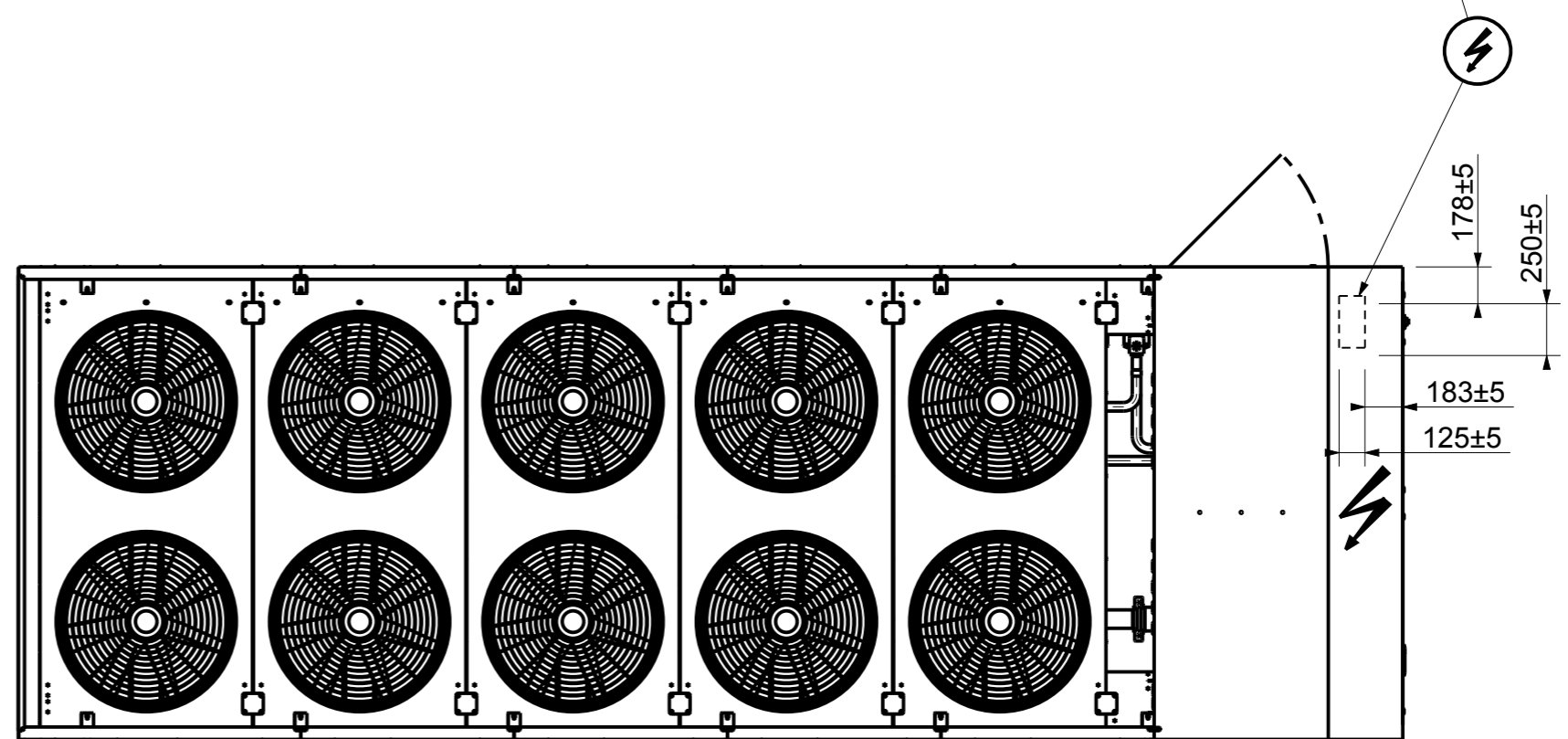

NAC600DNM3M / NAC640DNM3M