

Application guide



NEOSYS 200 - 1000 kW

NAC Air cooled liquid chiller
NAH Heat pump



NEOSYS™

APPLICATION GUIDE

Ref : NEOSYS-AGU-0610-E

1. GENERAL	
Model number description	2
Key customer benefits	3
Features and benefits	4
Technical description	6
Options and accessories	8
2. GENERAL DATA	
General data	10
Pressure drops	15
Hydraulic data	16
Acoustic data	19
Operating limits	20
4. ELECTRICAL DATA	
Electrical tables	21
5. PERFORMANCES	
NAC	24
NAH	26
Partial heat recovery	28
Free cooling	29
6. DIMENSIONAL DATA	
Dimensional data	31
Weight data	40

Our company is member of the Eurovent certification program.
The NEOSYS™ Lennox chillers are tested and rated in accordance with Eurovent certification program.



Our products comply with the European standards.



Product designed and manufactured under quality management systems certified ISO 9001 and ISO 14001.



Version 2008 Version 2004

All the technical and technological information contained in this manual, including any drawing and technical descriptions provided by us, remain the property of Lennox and must not be utilised (except in operation of this product), reproduced, issued to or made available to third parties without the prior written agreement of Lennox.

EXAMPLE : NAC 200D N M3 M

N	NEOSYS™
A	Air cooled
C	C = Cooling mode H = Heat pump mode
200	Cooling capacity in kW
D	Number of circuits : S = 1 circuit D = 2 circuits T = 3 circuits F = 4 circuits
N	Non ducted
M	R410 A refrigerant
3	Revision number
M	400V/3/50 Hz

**Air-cooled Liquid Chiller for outdoor installation (NAC)
Air-to-water Heat Pump for outdoor installation (NAH)**

Nominal cooling capacity:
200 to 1000 kW (NAC)
200 to 450 kW (NAH)

Nominal heating capacity:
200 to 500 kW (NAH)



Sustainable Performance

- **Extended qualification tests** (vibration tests, run tests, field tests) to ensure superior reliability.
- **High efficiency aluminium micro channel heat exchanger** (MCHX) with improved corrosion resistance for moderate marine or urban applications (Cooling only version). **3-year warranty***.
- **Specific MCHX coil design** with high mechanical fin resistance that offers easy cleaning with high pressure air or water washers for extended life cycle.
- **V-coil design**, compressor and hydraulic enclosure to protect the unit against climatic conditions (e.g. sun rays, UV light, hail).
- **Exclusive Compliant Scroll® compressor design** with both axial and radial compliance to increase compressor operation tolerance of liquid refrigerant or debris, substantially improving durability and reliability. **3-year warranty***.
- **Exclusive fan design with SKF hybrid Ceramic bearings** to double (treble in some cases) the service life of the motors and to reduce noise level. With these sealed hybrid ceramic bearings, our customer can expect little or no maintenance of the motor throughout its life. **3-year warranty***.

Quiet performance

- **Unique design** with compressor, pump(s) and fan acoustic enclosure to reduce radiated noise emissions.
- **Inverter fans** using external rotor technology associated with high performance aluminium fan blades of the latest generation (Owlet™ design).
- **Elimination of intrusive fan start/stop noise** that is irritating to the human ear.
- **Active Acoustic Attenuation System™** to meet changing building load requirements while automatically adjusting the air flow to meet night and day sound level constraints (Time schedule with 4 time zones per day).

Quick performance and service

- **Complete hydraulic module** with single or twin, low or high pressure pump (options) that includes all necessary equipment for quick connection: pump(s), regulating valve, expansion tank vessel with pressure gauge, pressure tapping points, water filter, air vent, pressure relief valve and Victaulic connections.
- 400V, 50 Hz, 3 phase power supply (without neutral) with a single point of power connection. Main on/off switch included in as standard.
- **Air spring powered Butterfly™ electrical panel** with jacks top opening providing protection to service engineers against rain or snow during commissioning and maintenance operations.

Energy performance

- **High Energy Performance** (ESEER above 4; EER up to 2.9 ; COP up to 3,2) for improved energy consumption all around the year.
- **Aluminium micro channel heat exchanger** that offers +10% outstanding system efficiency (cooling only version).
- **R410A refrigerant** for optimized system performance.
- **Energy savings** due to lower system minimum water content reducing the time to reach setpoint. This can also eliminate the need for a buffer tank.

Architectural integration

- **State of the art design** with hidden compressors, fans and pump for perfect architectural integration.
- **Flat top, aesthetic grilles, very low unit height** (< 2 m) for discrete installation on a roof reducing the requirement of costly cladding solutions around the unit.

* This warranty covers parts only. The above warranty is liable if the start-up and periodic maintenance agreement is contracted by a LENNOX company or any company accredited by LENNOX. Refer to LENNOX 3 year warranty conditions.

Flat top and low profile for best architectural integration



The NEOSYS™ design is minded to be perfectly integrated into urban or residential environments. The state of the art design of NEOSYS™ includes a painted casing with rounded side panels, a flat top that hides the fans, aesthetic protection grilles. The very low unit height less than two meters makes easier for architects and design engineers to integrate the unit on a roof. Many interviewed customers confirm that the state of the art design of NEOSYS™ will replace any requirement of costly cladding solutions around the unit.

Smarts acoustics with inverter fans

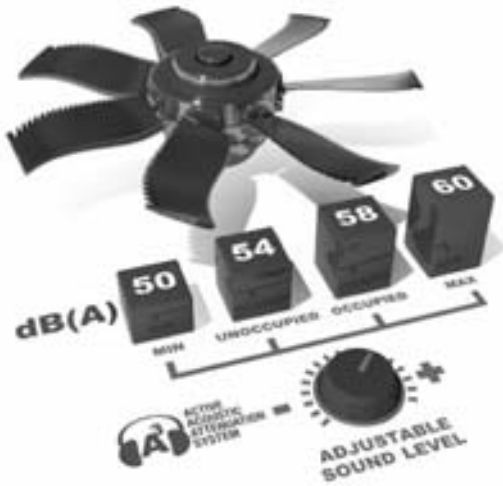

No more need to make a choice between a high efficiency version, a low noise or an ultra low noise version. NEOSYS™ can adapt all situations with only one version. NEOSYS™ is fitted in standard with the Active Acoustic Attenuation System™ that is using an electronic control associated with inverter fans. NEOSYS™ can change automatically the speed of all the fans – from 0% to 100% of the nominal air flow – to meet the building load requirements while respecting maximum authorised noise level in the time zone. NEOSYS™ is surely achieving the best acoustic signature of the market thanks to the latest generation of Owllet™ high performance aluminium fan blades and noiseless ceramic bearings.

ACTIVE ACOUSTIC ATTENUATION SYSTEM™

SELECT YOU MODE PER TIME ZONE

Performance Mode

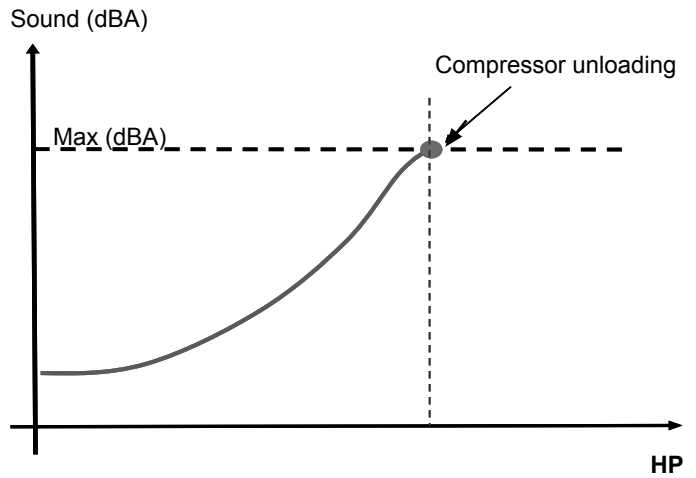

Quiet Mode

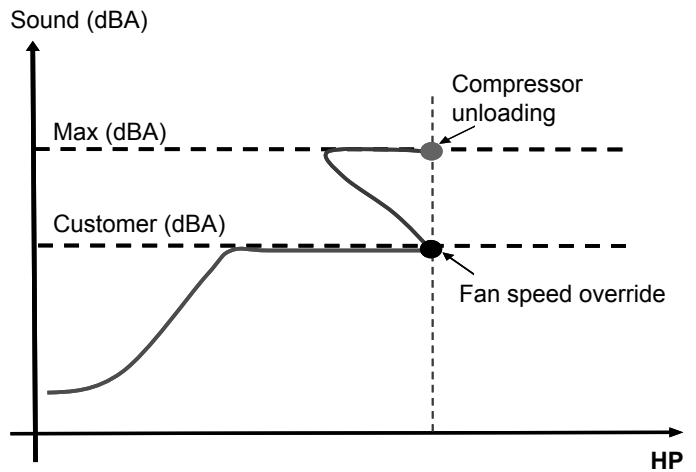

Quiet ++ Mode

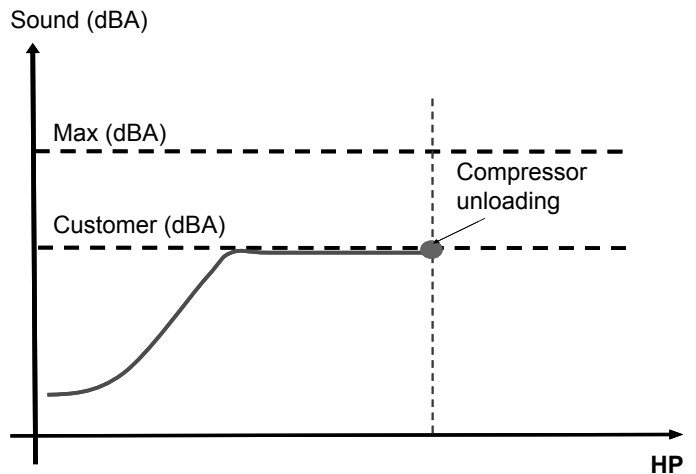

A high energy performance

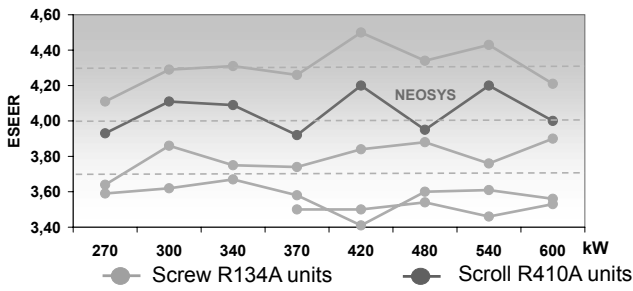

By using R410A refrigerant associated with high efficiency micro channel coils and variable speed fans NEOSYS™ is contributing to a very low energy consumption all year around with an average energy efficiency ratio (ESEER)* in cooling mode above 4.0. NEOSYS™ Heat-pumps are also achieving very high performances in cooling and heating mode (COP* up to 3.2). Furthermore NEOSYS™ advanced control allows energy savings all year around by using smart control functions:

- Low water system quantity to reduce the time to reach the set-point.
- Dynamic defrost (patented) to limit the number of defrost cycles.
- Set-point reset based on outside air temperature to relax the chilled water set-point.

*ESEER : European Seasonal Energy Efficiency Ratio in cooling mode.
COP : Coefficient of Performance in heating mode.

R410A Micro channel heat exchanger

With the use of fully aluminium coils already used in the automotive industry, NEOSYS™ offers many customer benefits:

- Up to 40% less refrigerant charge that contributes to reduce the total amount of refrigerant used in the system.
- A more efficient system (EER + 10%).
- An air heat exchanger with significantly improved corrosion resistance results (x 2) from the same aluminium alloy (no galvanic action) vs. the traditional copper tube/aluminium fin coils. By using this type of coil, units can be used in light corrosive or seacoast environments without any need for additional, and expensive, pre-treated fins or coil coating.
- High mechanical resistance eases the cleaning with high pressure air or water washers without any risk of damaging the fins.

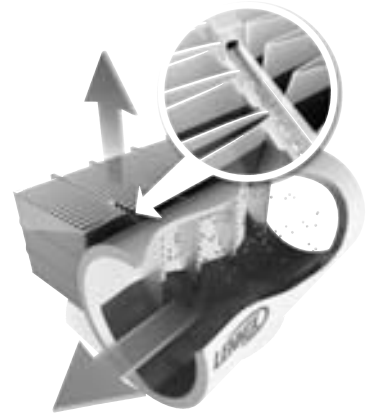

Available in cooling only version, this technology will surely be enlarged shortly to reversible applications.

GENERAL CHARACTERISTICS OF THE UNIT

The NEOSYS™ unit is designed to be integrated into urban or residential environments.

As main characteristics the NEOSYS™ unit offers **state of the art design** to match architectural constraints and **adjustable sound level performances** during day and night to satisfy local environmental constraints.

CASING/CHASSIS

- Casing made of galvanised steel sheet metal painted with a white RAL 9002 powdered polyester paint and a RAL3003 red stripe.
- Fully RAL 7016 grey colour painted chassis protecting against corrosion.
- **State of the art design** with hidden compressors, fans and pump for perfect architectural integration.
- Flat top, aesthetic grilles, **very low unit height (< 2m)** for discrete installation on a roof reducing the requirement of costly cladding solutions around the unit
- **Aesthetic side anti-intrusion grilles** as standard to protect the unit during transportation and against human aggressions.

COMPRESSOR

- Exclusive Compliant Scroll® design with both axial and radial compliance to increase compressor operation tolerance to liquid refrigerant, substantially improving durability and reliability. **3-year warranty***.
- Motor cooled by suction gas.
- Electronic control of the compressor discharge temperature.
- Motor protection device against high temperature or over current situations.
- Discharge non-return valve.
- Low noise scroll compressors mounted in a sound-proofed technical cabinet to reduce noise emissions.
- Compressors assembly installed on an independent chassis supported by anti-vibration mountings.

WATER HEAT EXCHANGER

- True dual circuit plate heat exchanger
- Copper brazed Stainless steel plate heat exchanger.
- 13 mm thermal insulation foam.
- Water heat exchanger located in a technical cabinet protecting the insulation against climatic conditions (UV light, rain).

AIR HEAT EXCHANGER

- High efficiency aluminium Micro Channel heat exchangers (MCHX) with improved corrosion resistance in moderate marine or urban environment (cooling only version). **3-year warranty***.
- Standard copper tubes/aluminium fins heat exchanger (heat pump version).
- V-coil design to protect the unit against climatic conditions (e.g. hail).

FANS

- Inverter fans (0 to 900 rpm operating range).
- **Active Acoustic Attenuation System™** to meet changing building load requirements while automatically adjusting the air flow to respect night and day sound level constraints (adjustable setting over time schedule with 4 time zones per day).
- Elimination of intrusive start/stop noise that is irritating to the human ear.
- Fan-motor assembly using external rotor technology associated with owl high performance aluminium fan blades of the latest generation.
- IP 54 electrical motor, class F protected against high temperature with an internal sensor.
- Exclusive fan design with hybrid Ceramic bearings to extend the service life of motors and to reduce noise level. With these sealed hybrid ceramic bearings, our customer can expect little or no maintenance of the motor throughout its life. **3-year warranty***.
- Extremely rigid fan assembly via the integration of the fans mounted within a pre-formed bell mouth roof panel, thus improving rigidity while reducing vibrations.
- Rounded top acoterion panels to hide the fans and reduce noise emissions for quieter operation.

REFRIGERANT CIRCUIT

NEOSYS™ is using R410A refrigerant in 2 independent circuits (minimum). Each circuit includes:

- **A refrigerant charge reduced by 30%** due to the use of R410A combined with micro channel heat exchanger (NAC/Cooling only version).
- Suction piping with thermal insulation.
- Filter drier with removable cartridge filter.
- Thermostatic or electronic expansion valve (Electronic device only when "winter operation" option selected).
- Temperature sensors and pressure transducers.
- Four-way valve and liquid receiver (heat pump units only).
- Leak-tight refrigerant circuit with brazing carried out under nitrogen by certified engineers.
- Each refrigerant circuit is pressure and leak tested with a Hydrogen/Nitrogen mixture, and vacuumed before being charged with refrigerant. All units are then subjected to a complete functional and operational run test to guarantee perfect sealing before leaving the factory.

* Warranty under conditions - See page 3

ELECTRICAL BOX

- Unit electrical cabinet, components and wiring in compliance with EN 60204-1 electrical directive.
- 400V, 50 Hz, 3 phase power supply (without neutral) with a single point of power connection (except sizes 680 to 1080).
- Bottom entry (through the base) for electrical power.
- IP54 protection class.
- **Air spring powered Butterfly™ electrical panel** with top opening providing protection to the service engineers against rain or snow during commissioning and maintenance operations.
- Recognized brand electrical components (Schneider) for ease of maintenance.
- Main on/off switch mounted on the front panel.
- DC50™ user interface mounted on the front panel.
- Main disconnect switch with high trip capacity allowing optimized sizing of the customer power supply.
- 400/24 V transformer to supply the control circuit.
- Numbered electrical wires to facilitate maintenance and diagnostic.
- Variable Frequency Drives (VFD) to control the fan speed.

CONTROL

CLIMATIC™ microprocessor based control is providing the following functions:

- 4 scheduling time zones per day over 7 days to allow energy consumption and sound level management according to the building use and environmental constraints.
- PI control of the water temperature with operating time equalisation of the compressors.
- Water set-point offset based on outdoor air temperature.
- **Active variable speed control of all fans** to optimize the unit condensing pressure and energy performances at full- and part-load while meeting authorized maximum noise level in the time zone (Active Acoustic Attenuation System™ control patented).
- Intelligent advanced control algorithm to protect the compressors against excessive short-cycling and to allow **operation of the unit without buffer tank** in most comfort air conditioning applications (e.g. unit with fan-coils). Refer to minimum installation water loop volume recommendations.
- **Dynamic defrost** to limit the number and the duration of the defrost cycles in winter for high performance of the unit (Dynamic Defrost patented).
- Automatic compressor unloading in case of excessive condensing pressure allowing the operation of the machine at high outdoor air temperature (operation extended up to 46°C ambient).
- Water pump control with operating time equalization and automatic change-over in case of a pump fault (Twin pump only).
- Master/slave or cascade control of two chillers operating in parallel with operating time equalization and automatic change-over in case of a unit fault.

CLIMATIC™ is pre-factory configured with default settings allowing a fast commissioning on site. The DC50™ user interface with graphical display is easy to use, intuitive. Main customer parameters can be read or modified without main power shut-off (Entering/leaving water temperatures, outdoor air temperature, alarm history, scheduling of the different time zone, water and noise level set-points, high and low pressure reading).

The DS50™ service display (optional) is a "plug and play" controller that allows service people to read and modify all unit parameters (Unit settings, operating time and number of compressor starts, low and high pressure reading, read the history of last 32 faults...).

COMMUNICATION

The control board is equipped with a RS485 serial communication port to allow remote management through communication bus. According to the wished communication protocol, our control board can be fitted with **ModBUS®, LonWorks® or BacNET® communication interface** (options).

The main control board has free dry contacts that allow remote control of the unit by wired cable:

- Remote on/off of the unit.
- Remote alarm reset to re-start the unit.
- Alarm or alert indications.
- Free customer contact.

With the optional extension board BE50™, it is possible to get additional customized digital or analog inputs / outputs for remote control of the unit:

- Fault fans or pumps (dry contact).
- Operation indication at 100% on circuit 1 or 2 (dry contact).
- Dual water set-point management (dry contact).
- Force heating or cooling mode (24V AC input).
- Power limitation by disabling circuit 1 or 2 (24V AC input).
- Force unoccupied mode (24V AC input).
- Water set-point offset based on a 4-20mA signal. Note: non available with heat-pump units.

DIRECTIVES

The unit is built to meet European norms and standards & Eurovent certification performance standards.

- DI 97/23/CE Pressure Equipment Directive.
- DI 98/37/CE Machinery Directive.
- DI 73/23/CE Low Voltage Directive.
- DI 89/336/CE Electro Magnetic Compatibility Directive
- EN 378-2 Safety and Environmental Directive.
- **The European Restriction of the Use of Certain Hazardous Substances (RoHS).**

OPTIONS	DESCRIPTION	ADVANTAGES	MODELS
Low-pressure single-pump hydraulic module	Low-pressure single pump, regulating valve, Victaulic couplings, filter and all necessary hydraulic devices. Refer to specific chapter.	Quick start-up on job site. Available pressure around 150 kPa.	NAC 200 ► 640 NAH 200 ► 480
High-pressure single-pump hydraulic module	High-pressure single pump, regulating valve, Victaulic couplings, filter and all necessary hydraulic devices. Refer to specific chapter.	Quick start-up on job site. Available pressure around 250 kPa.	NAC 200 ► 640 NAH 200 ► 480
Low-pressure twin-pump hydraulic module	Low-pressure twin pumps, regulating valve, Victaulic couplings, filter and all necessary hydraulic devices. Refer to specific chapter.	Quick start-up on job site. Available pressure around 150 kPa.	NAC 200 ► 640 NAH 200 ► 480
High-pressure twin-pump hydraulic module	High-pressure twin pumps, regulating valve, Victaulic couplings, filter and all necessary hydraulic devices. Refer to specific chapter.	Quick start-up on job site. Available pressure around 250 kPa.	NAC 200 ► 640 NAH 200 ► 480
Partial heat recovery	Plate heat exchanger on each compressor circuit allowing recovery of 20% of the rejected heat	Allow free hot water production simultaneously with unit operation	NAC 200 ► 640 NAH 200 ► 300
Free cooling	Additional free cooling coils (one “V” or two “V” depending on needed capacity) with inverter fans and motorised valves.	Allow the chilled water to run through the free-cooling system, which uses less power and utilises the lower ambient air to cool the water.	NAC 200 ► 540
Winter operation (from +6°C down to -20°C) – Cooling only units	Unit fitted with electronic expansion valve and variable frequency driven fans. Select “anti-freeze protection” option if no glycol water	Increased operating range in cooling down to -20°C ambient temperature. (Standard on sizes 540/600/640/1080).	NAC 200 ► 480 NAC 680 ► 960
Brine operation (From +5°C down to -10°C)	Unit fitted with electronic expansion valve, variable frequency driven fans and reinforced evaporator and piping thermal insulation.	Increased operating range in cooling down to -10°C water leaving temperature for thermal storage or process cooling.	NAC 200 ► 1080
Anti-freeze protection (down to -20°C)	Resistance heaters on the evaporator, hydraulic module and partial heat recovery if selected. To be selected if no glycol water.	Evaporator and hydraulic module frost protection down to -20°C ambient temperature	NAC 200 ► 1080 NAH 200 ► 480
Heavy anti-corrosion coil treatment	Application of Thermoguard® treatment on the entire coil surface.	High corrosion resistance for severe industrial and marine environments.	NAC 200 ► 1080 NAH 200 ► 480
Rear protection grille	Metallic grille fitted at the back of the unit	Prevents the rear V-coil against possible damage	NAC 200 ► 640 NAH 200 ► 480
Soft starter	Electronic soft starter fitted into the electrical cabinet	Start-up current reduced by 15 % up to 30 %.	NAC 200 ► 1080* NAH 200 ► 480
Power Factor correction	Capacitors fitted into the unit	Cos phi correction up to 0.95 to reduce current and energy consumption.	NAC 200 ► 1080 NAH 200 ► 480

*except in case of main power connection option

OPTIONS	DESCRIPTION	ADVANTAGES	MODELS
Electric meter	Active energy total counter, power factor, operating time counter, max. active power demand, ModBus.	This device allows monitoring of the unit electric power consumption on the unit and from a BMS	NAC 200 ► 1080 NAH 200 ► 480
Single main power connection	Electrical cabinet equipped with one single point of connection and power cut-off for the complete unit.	Allow easy electrical connection with one single cable instead of two cables	NAC 680 ► 1080
BE50™ extension board for additional inputs/ outputs	Electronic extension board with additional analog inputs (4), digital inputs (4) and digital outputs (4). See control manual.	Relay card for remote control and alarm report using dry contacts, 24 Vac or 4-20 mA signals.	NAC 200 ► 1080 NAH 200 ► 480
Modbus communication interface	Communication card using ModBus/JBus protocol.	Communication interface with a building management system.	NAC 200 ► 1080 NAH 200 ► 480
LonWorks® communication interface	Communication card using LonTalk® protocol.	Communication interface with a building management system.	NAC 200 ► 1080 NAH 200 ► 480
BACnet® communication interface	Communication card using Bacnet® protocol.	Communication interface with a building management system.	NAC 200 ► 1080 NAH 200 ► 480

ACCESSORIES	DESCRIPTION	ADVANTAGES	MODELS
Water filter	1000 microns water filter delivered with piping and Victaulic connections. Not necessary if 'hydraulic module' option selected.	This protection must be fitted in the customer water supply piping to protect the evaporator from any possible impurities.	NAC 200 ► 1080 NAH 200 ► 480
Flange connection	Two connections sleeves with victaulic groove and flange on opposite side.	Allow easy connection with flanges on customer side.	NAC 200 ► 1080 NAH 200 ► 480
Anti-vibration mounts	Rubber anti-vibration mounts to be mounted under the unit.	Reduction of the transmission of vibration to the ground and the general level.	NAC 200 ► 1080 NAH 200 ► 480
DC50™ remote comfort display	Customer display located at 600 meters maximum from the unit.	Remote customer parameter reading and modification.	NAC 200 ► 1080 NAH 200 ► 480
DS50™ service display	Plug and play display delivered with 1 meter cable and connector for quick connection on Climatic controller.	Display for service technicians only.	NAC 200 ► 1080 NAH 200 ► 480
Adalink™ supervision	Electronic board with RS485 cables, RJ11 phone cable, Ethernet cable and power supply cable.	Remote supervision of the unit via an intuitive web page.	NAC 200 ► 1080 NAH 200 ► 480

COOLING ONLY

NAC

NEOSYS™	NAC	200	230	270	300	340	380
Cooling mode							
Cooling capacity ⁽¹⁾	kW	208,2	235,7	272,8	307,6	351,3	387,3
Power input ⁽¹⁾	kW	72,1	85,7	106,7	106,9	125,6	149,1
Full load amps ⁽¹⁾	A	125,3	149,1	185,5	186,0	218,5	259,3
EER ⁽²⁾		2,89	2,75	2,56	2,88	2,80	2,60
ESEER ⁽³⁾		4,24	4,03	3,99	4,04	4,15	3,90
Acoustic		Active Acoustic Attenuation System™					
Global sound power level ⁽¹⁾ High performance	dB(A)	89	89	89	91	91	91
Global sound power level ⁽¹⁾ Quiet mode	dB(A)	84	84	85	86	87	87
Global sound power level ⁽¹⁾ Super quiet mode	dB(A)	82	83	84	85	85	86
Compressor		Scroll - Hermetic					
Number of compressor	nr	4	4	4	4	5	5
Capacity steps	%	19-38-50- 62-81-100	16-32-50- 68-84-100	22-44-50- 57-78-100	20-47-73- 100	18-41-59- 82-100	20-40-60- 80-100
Oil charge per compressor	l	(3,2+6,8) + (3,2+6,8)	(3,2+6,3) + (3,2+6,3)	(6,8+6,3) + (6,8+6,3)	(6,3x2) + (6,8+6,3)	(6,8x3) + (6,3x2)	(6,3x3) + (6,3x2)
Oil type	type	MOBIL EAL Arctic 22CC or ICI EMKARATE RL32CF					
Refrigerant		R410A					
Expansion	type	Thermostatic expansion valve					
Number of circuit	nr	2	2	2	2	2	2
Charge per circuit	kg	17	17	17	25,5	25,5	25,5
Condenser		Microchannel Aluminium Tube and fins					
Fan & Motor		Variable speed fans					
Number of fan		4	4	4	6	6	6
Diameter	mm	800	800	800	800	800	800
Maximum speed	rpm	Variable speed - 900 rpm maximum					
Nominal air flow (100%)	m³/h	87 200	87 200	87 200	130 800	130 800	130 800
Total motor power input (900 rpm)	kW	6,4	6,4	6,4	9,6	9,6	9,6
Evaporator		AISI 316 stainless steel plate brazed with copper heat exchanger					
Water flow ⁽¹⁾	m³/h	35,8	40,6	46,9	52,9	60,4	66,6
Water volume	l	13	13	16	24	35	35
Pressure drop ⁽¹⁾	kPa	43,0	54,1	55,9	48,1	34,7	41,6
Water operating pressure	kPa	600	600	600	600	600	600
Hydraulic connections		Victaulic					
Water inlet/outlet	Inches	4"	4"	4"	4"	5"	5"
Electrical data		400V / III / 50 Hz					
Start-up intensity	A	397,7	450,1	478,4	500,0	530,9	574,1
Maximum current	A	170,6	199,4	227,7	249,3	280,2	323,4
Dimensions							
Length	mm	3590	3590	3590	4620	4620	4620
Width	mm	2280	2280	2280	2280	2280	2280
Height	mm	1964	1964	1964	1964	1964	1964
Footprint	m²	8,2	8,2	8,2	10,5	10,5	10,5
Operating weight	kg	1984	2011	2259	2648	2938	3010
Shipping weight	kg	1962	1989	2234	2615	2889	2962
Construction							
Frame		Cataphoresis and Galvanised - RAL 7016					
Casing		Galvanised steel					
Painting		Polyester - RAL 9002/RAL 7016/RAL 3003					

(1) All data are at Eurovent condition.
Gross cooling capacity with 12/7°C water temperature and 35°C air ambient.
Gross heating capacity with 7°C air inlet temperature and 40/45°C water temperature.
(2) EER and COP according to EN14511 Eurovent calculation method
(3) ESEER according to EN14511 Eurovent calculation method.

(NA) Not available.
OPERATING LIMITS on page 19.

NEOSYS™ is part of LCP Eurovent Certification Program (All models are certified up to 600 kW) (www.eurovent-certification.com).

COOLING ONLY

NAC

NEOSYS™	NAC	420	480	540	600	640
Cooling mode						
Cooling capacity ⁽¹⁾	kW	429,6	489,9	530,9	605,0	626,9
Power input ⁽¹⁾	kW	152,3	174,3	201,9	219,1	226,1
Full load amps ⁽¹⁾	A	264,9	303,2	351,1	381,1	393,2
EER ⁽²⁾		2,82	2,81	2,63	2,76	2,77
ESEER ⁽³⁾		4,19	4,01	4,0	4,15	4,17
Acoustic		Active Acoustic Attenuation System™				
Global sound power level ⁽¹⁾ High performance	dB(A)	92	92	93	94	94
Global sound power level ⁽¹⁾ Quiet mode	dB(A)	88	88	89	90	90
Global sound power level ⁽¹⁾ Super quiet mode	dB(A)	86	87	88	89	89
Compressor		Scroll - Hermetic				
Number of compressor	nr	6	6	6	6	6
Capacity steps	%	14-33-48-67-81-100	17-33-50-67-83-100	18-33-51-67-85-100	17-33-50-67-83-100	17-33-50-67-83-100
Oil charge per compressor	l	(6,3x3) + (6,8x3)	(6,3x3) + (6,3x3)	(6,3x3) + (6,3x3)	(6,3x3) + (6,3x3)	(6,3x3) + (6,3x3)
Oil type	type	MOBIL EAL Arctic 22CC or ICI EMKARATE RL32CF				
Refrigerant		R410A				
Expansion	type	Thermostatic expansion valve		Electronic expansion valve		
Number of circuit	nr	2	2	2	2	2
Charge per circuit	kg	34	34	34	42,5	42,5
Condenser		Microchannel aluminium tube and fins - Air cooled				
Fan & Motor		Variable speed fans				
Number of fan		8	8	8	10	10
Diameter	mm	800	800	800	800	800
Maximum speed	rpm	Variable speed - 900 rpm maximum				
Nominal air flow (100%)	m ³ /h	174 400	174 400	174 400	218 000	218 000
Total motor power input (900 rpm)	kW	12,8	12,8	12,8	16	16
Evaporator		AISI 316 stainless steel plate brazed with copper heat exchanger				
Water flow ⁽¹⁾	m ³ /h	73,9	84,3	91,3	104,1	107,9
Water volume	l	35	43	43	52	56
Pressure drop ⁽¹⁾	kPa	50,3	48,8	56,7	59,0	58,4
Water operating pressure	kPa	600	600	600	600	600
Hydraulic connections		Victaulic				
Water inlet/outlet	Inches	5"	5"	6"	6"	6"
Electrical data		400V / III / 50 Hz				
Start-up intensity	A	597,8	641,0	754,0	804,7	804,7
Maximum current	A	347,0	390,3	433,8	484,5	484,5
Dimensions						
Length	mm	5650	5650	5650	6680	6680
Width	mm	2280	2280	2280	2280	2280
Height	mm	1964	1964	1964	1964	1964
Footprint	m ²	12,9	12,9	12,9	15,2	15,2
Operating weight	kg	3512	3621	3621	3992	4030
Shipping weight	kg	3463	3564	3565	3927	3960
Construction						
Frame		Cataphoresis and Galvanised - RAL7016				
Casing		Galvanised steel				
Painting		Polyester - RAL 9002/RAL 7016/RAL 3003				

(1) All data are at Eurovent condition,
Gross cooling capacity with 12/7°C water temperature and 35°C air ambient.
Gross heating capacity with 7°C air inlet temperature and 40/45°C water temperature.
(2) EER and COP according to EN14511 Eurovent calculation method
(3) ESEER according to EN14511 Eurovent calculation method.

(NA) Not available.

OPERATING LIMITS on page 19.

NEOSYS™ is part of LCP Eurovent Certification Program (All models are certified up to 600 kW) (www.eurovent-certification.com).

COOLING ONLY

NAC

NEOSYS™	NAC	680	760	840	960	1080
Cooling mode						
Cooling capacity ⁽¹⁾	kW	702,6	774,7	859,1	979,8	1061,9
Power input ⁽¹⁾	kW	251,3	298,2	304,6	348,7	403,8
Full load amps ⁽¹⁾	A	436,9	518,5	529,8	606,3	702,2
EER ⁽²⁾		2,80	2,60	2,82	2,81	2,63
ESEER ⁽³⁾		4,15	3,91	4,21	4,01	4,0
Acoustic		Active Acoustic Attenuation System™				
Global sound power level ⁽¹⁾ Alto rendimiento	dB(A)	94	94	95	95	96
Global sound power level ⁽¹⁾ Quiet mode	dB(A)	90	90	91	91	92
Global sound power level ⁽¹⁾ Super quiet mode	dB(A)	88	89	89	90	91
Compressor		Scroll - Hermetic				
Number of compressor	nr	10	10	12	12	12
Capacity steps	%	9-18-30-41-50-59-70-82-91-100	10-20-30-40-50-60-70-80-90-100	8-15-24-33-41-48-58-67-74-82-91-100	8-17-25-33-42-50-58-67-75-83-92-100	8-15-24-33-41-48-58-67-74-82-91-100
Oil charge per compressor	l	[(6,8x3) + (6,3x2)] x 2	[(6,3x3) + (6,3x2)] x 2	[(6,3x3) + (6,8x3)] x 2	[(6,3x3) + (6,3x3)] x 2	
Oil type	type	MOBIL EAL Arctic 22CC or ICI EMKARATE RL32CF				
Refrigerant		R410A				
Expansion	type	Thermostatic expansion valve				Electronic expansion valve
Number of circuit	nr	4	4	4	4	4
Charge per circuit	kg	25,5	25,5	34	34	34
Condenser		Microchannel aluminium tube and fins				
Fan & Motor		Variable speed fans				
Number of fan		12	12	16	16	16
Diameter	mm	800	800	800	800	800
Maximum speed	rpm	Variable speed - 900 rpm maximum				
Nominal air flow (100%)	m³/h	261 600	261 600	348 800	348 800	348 800
Total motor power input (900 rpm)	kW	19,2	19,2	25,6	25,6	25,6
Evaporator		AISI 316 stainless steel plate brazed with copper heat exchanger				
Water flow ⁽¹⁾	m³/h	120,9	133,3	147,8	168,6	182,7
Water volume	l	275	290	300	335	345
Pressure drop ⁽¹⁾	kPa	57,0	51,3	56,0	66,0	71,0
Water operating pressure	kPa	600	600	600	600	600
Hydraulic connections		Victaulic				
Water inlet/outlet	Inches	8"				
Electrical data		400V / III / 50 Hz				
Start-up intensity	A	811,0	897,5	944,8	1031,2	1187,7
Maximum current	A	560,3	646,8	694,1	780,5	867,5
Dimensions						
Length	mm	9040	9040	11100	11100	11100
Width	mm	2280	2280	2280	2280	2280
Height	mm	1964	1964	1964	1964	1964
Footprint	m²	20,6	20,6	25,3	25,3	25,3
Operating weight	kg	6720	6860	8000	8160	8160
Shipping weight	kg	6445	6570	7700	7825	7815
Construction						
Frame		Cataphoresis and Galvanised - RAL 7016				
Casing		Galvanised steel				
Painting		Polyester - RAL 9002/RAL 7016/RAL 3003				

(1) All data are at Eurovent condition, Gross cooling capacity with 12/7°C water temperature and 35°C air ambient. Gross heating capacity with 7°C air inlet temperature and 40/45°C water temperature.
 (2) EER and COP according to EN14511 Eurovent calculation method
 (3) ESEER according to EN14511 Eurovent calculation method.

(NA) Not available.

OPERATING LIMITS on page 19.
 NEOSYS™ is part of LCP Eurovent Certification Program (All models are certified up to 600 kW) (www.eurovent-certification.com).

HEAT PUMP

NAH

NEOSYS™	NAH	200	230	270	300
Cooling mode					
Cooling capacity ⁽¹⁾	kW	191	217	271	295
Power input ⁽¹⁾	kW	73,5	86,7	106,7	117,0
Full load amps ⁽¹⁾	A	127,9	150,7	185,6	203,5
EER ⁽¹⁾		2,60	2,50	2,54	2,52
ESEER ⁽²⁾		4,00	3,76	3,99	3,94
Heating mode					
Heating capacity ⁽¹⁾	kW	219	252	313	346
Power input ⁽¹⁾	kW	70,4	83,2	104,3	114,6
Full load amps ⁽¹⁾	A	125,9	145,3	172,8	192,5
COP ⁽³⁾		3,11	3,03	3,00	3,02
Acoustic					
Active Acoustic Attenuation System™					
Global sound power level ⁽¹⁾ High performance	dB(A)	89	89	90	91
Global sound power level ⁽¹⁾ Quiet mode	dB(A)	84	84	86	86
Global sound power level ⁽¹⁾ Super quiet mode	dB(A)	82	83	84	85
Compressor					
Scroll - Hermetic					
Number of compressor	nr	4	4	4	4
Capacity steps	%	19 - 38 - 50 - 62 - 81 - 100	16 - 32 - 50 - 68 - 84 - 100	22 - 43 - 50 - 57 - 78 - 100	25 - 50 - 75 - 100
Oil charge per compressor	l	(3,2+6,8) + (3,2+6,8)	(3,2+6,3) + (3,2+6,3)	(6,8+6,3) + (6,8+6,3)	(6,3x2) + (6,3x2)
Oil type	type	MOBIL EAL Arctic 22CC or ICI EMKARATE RL32CF			
Refrigerant					
R410A					
Expansion	type	Thermostatic expansion valve			
Number of circuit	nr	2	2	2	2
Charge per circuit	kg	28	28	40	42
Condenser					
Copper tube - Aluminium fin - Air-cooled					
Fan & Motor					
Variable speed fans					
Number of fan		4	4	6	6
Diameter	mm	800	800	800	800
Maximum speed	rpm	Variable speed - 900 rpm maximum			
Nominal air flow (100%)	m ³ /h	76 000	76 000	114 000	114 000
Total motor power input	kW	6,4	6,4	9,6	9,6
Evaporator					
AISI 316 stainless steel plate brazed with copper heat exchanger					
Water flow ⁽¹⁾	m ³ /h	32,9	37,3	46,6	50,8
Water volume	l	20	20	23,2	23,2
Pressure drop ⁽¹⁾	kPa	36,7	46,4	55,2	44,7
Water operating pressure	kPa	600	600	600	600
Hydraulic connections					
Victaulic					
Water inlet/outlet	Inches	4"			
Electrical data					
400V / III / 50 Hz					
Start-up intensity	A	397,7	450,1	485,6	514,4
Maximum current	A	170,6	199,4	234,9	263,7
Dimensions					
Length	mm	3590	3590	4620	4620
Width	mm	2280	2280	2280	2280
Height	mm	1964	1964	1964	1964
Footprint	m ²	8,2	8,2	10,5	10,5
Operating weight	kg	2193	2193	2917	2925
Shipping weight	kg	2171	2171	2892	2892
Construction					
Frame		Cataphoresis and Galvanised - RAL 7016			
Casing		Galvanised steel			
Painting		Polyester - RAL 9002/RAL 7016/RAL 3003			

(1) All data are at Eurovent condition.
Gross cooling capacity with 12/7°C water temperature and 35°C air ambient.
Gross heating capacity with 7°C air inlet temperature and 40/45°C water temperature.
(2) EER and COP according to EN14511 Eurovent calculation method
(3) ESEER according to EN14511 Eurovent calculation method.

(NA) Not available.

OPERATING LIMITS on page 19.

NEOSYS™ is part of LCP Eurovent Certification Program (All models are certified up to 600 kW) (www.eurovent-certification.com).

HEAT PUMP

NAH

NEOSYS™	NAH	340	380	420	480
Cooling mode					
Cooling capacity ⁽¹⁾	kW	324	361	397	454
Power input ⁽¹⁾	kW	128,4	133,1	155,1	179,4
Full load amps ⁽¹⁾	A	223,3	231,4	269,7	311,9
EER ⁽¹⁾		2,52	2,71	2,56	2,53
ESEER ⁽²⁾		4,01	4,08	3,86	4,14
Heating mode					
Heating capacity ⁽¹⁾	kW	370	410	459	509
Power input ⁽¹⁾	kW	121,7	134,8	153,3	169,2
Full load amps ⁽¹⁾	A	125,9	145,3	172,8	192,5
COP ⁽³⁾		3,04	3,04	2,99	3,01
Acoustic					
Active Acoustic Attenuation System™					
Global sound power level ⁽¹⁾ High performance	dB(A)	91	92	92	92
Global sound power level ⁽¹⁾ Quiet mode	dB(A)	87	87	88	88
Global sound power level ⁽¹⁾ Super quiet mode	dB(A)	85	86	86	87
Compressor					
Scroll - Hermetic					
Number of compressor	nr	5	6	6	6
Capacity steps	%	18 - 41 - 59 - 82 - 100	17 - 33 - 50 - 67 - 83 - 100	14 - 33 - 48 - 67 - 81 - 100	17 - 33 - 50 - 67 - 83 - 100
Oil charge per compressor	l	(6,8 x 3) + (6,3 x 2)	(6,8 x 3) + (6,8 x 3)	(6,3 x 3) + (6,8 x 3)	(6,3 x 3) + (6,3 x 3)
Oil type	type	MOBIL EAL Arctic 22CC or ICI EMKARATE RL32CF			
Refrigerant					
R410A					
Expansion	type	Thermostatic expansion valve			
Number of circuit	nr	2	2	2	2
Charge per circuit	kg	42	50	52	52
Condenser					
Copper tube - Aluminium fin - Air-cooled					
Fan & Motor					
Variable speed fans					
Number of fan		6	8	8	8
Diameter	mm	800	800	800	800
Maximum speed	rpm	Variable speed - 900 rpm maximum			
Nominal air flow (100%)	m ³ /h	114 000	152 000	152 000	152 000
Total motor power input	kW	9.6	12.8	12.8	12.8
Evaporator					
AISI 316 stainless steel plate brazed with copper heat exchanger					
Water flow ⁽¹⁾	m ³ /h	55.7	62.1	68.4	78.1
Water volume	l	34.6	34.6	34.6	42.7
Pressure drop ⁽¹⁾	kPa	29.8	36.5	43.6	42.3
Water operating pressure	kPa	600	600	600	600
Hydraulic connections					
Victaulic					
Water inlet/outlet	Inches	5"			
Electrical data					
400V / III / 50 Hz					
Start-up intensity	A	530.9	581.3	597.8	641.0
Maximum current	A	280.2	330.6	347.0	390.3
Dimensions					
Length	mm	4620	5650	5650	5650
Width	mm	2280	2280	2280	2280
Height	mm	1964	1964	1964	1964
Footprint	m ²	10.5	12.9	12.9	12.9
Operating weight	kg	3233	3756	3927	4015
Shipping weight	kg	3184	3708	3878	3958
Construction					
Frame		Cataphoresis and Galvanised - RAL 7016			
Casing		Galvanised steel			
Painting		Polyester - RAL 9002/RAL 7016/RAL 3003			

(1) All data are at Eurovent condition,
Gross cooling capacity with 127°C water temperature and 35°C air ambient.
Gross heating capacity with 7°C air inlet temperature and 40/45°C water temperature.
(2) EER and COP according to EN14511 Eurovent calculation method
(3) ESEER according to EN14511 Eurovent calculation method.

(NA) Not available.

OPERATING LIMITS on page 19.

NEOSYS™ is part of LCP Eurovent Certification Program (All models are certified up to 600 kW)
(www.eurovent-certification.com).

EVAPORATORS CURVE

NAC	NAH	Curve	NAC	Curve
200		A	540	E
230			600	F
270			640	G
300		D	680	H
340			760	
380			840	
420		E	960	I
480			1080	

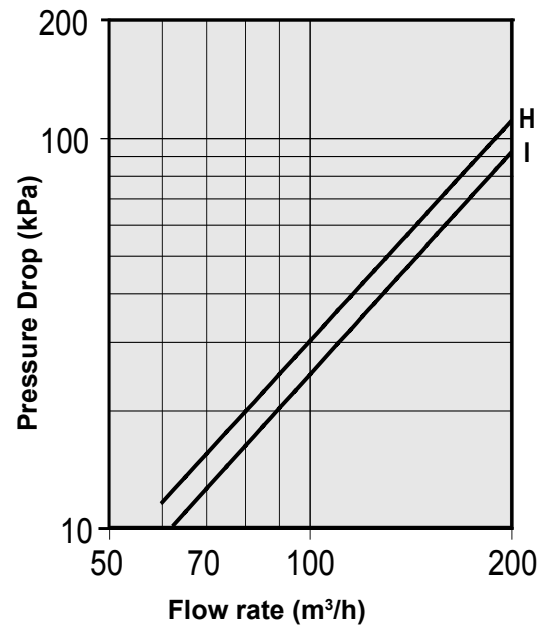
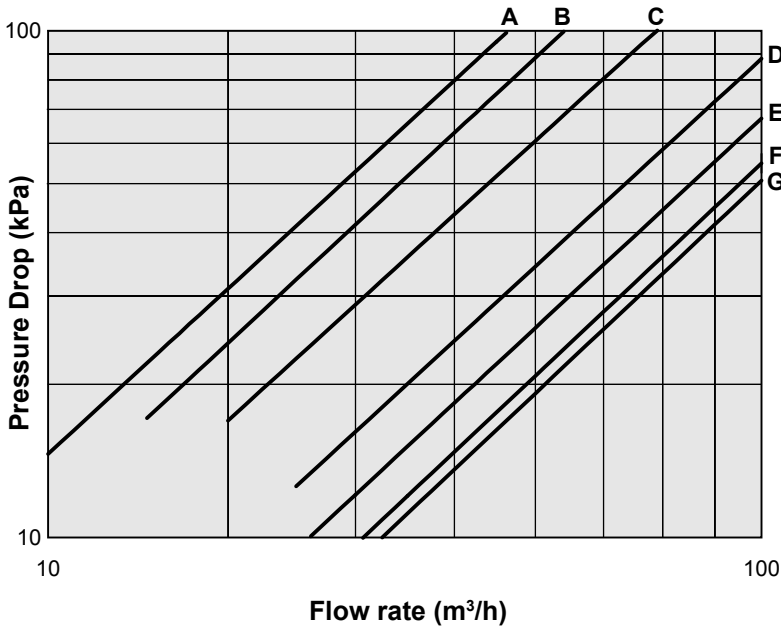

FILTER CURVE

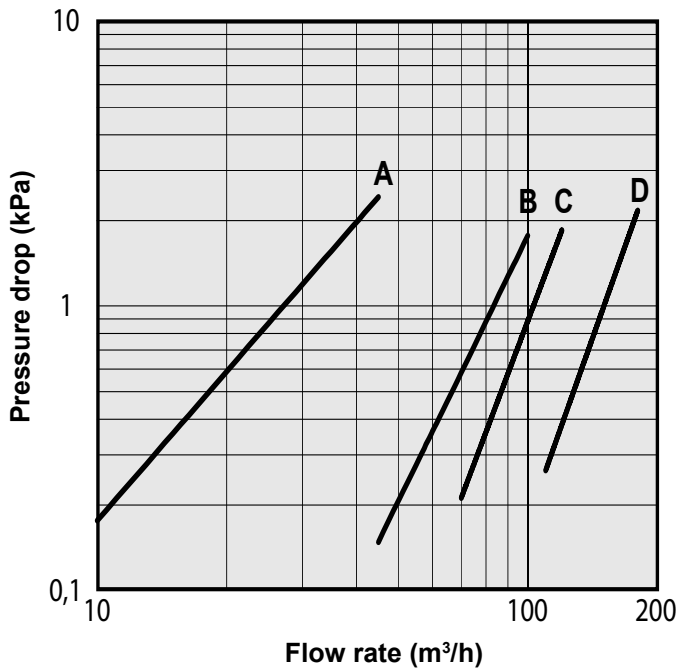

NAC	NAH	Curve
200		A
230		
270		
300		
340		B
380		
420		
480		
540	-	C
600	-	
640	-	
680	-	D
760	-	
840	-	
960	-	
1080	-	

Pressure drops are given for information only. A tolerance of +/- 20 kPa must be considered when selecting water pumps.

NAC		200	230	270	300	340	380	420	480	540	600	640
NAH										-	-	-
Nominal water flow	m ³ /h	35,8	40.5	46.9	52.9	60.4	66.6	73.9	84.3	91,3	104.0	107,8
Single pump												
Available static pressure ⁽¹⁾	kPa	101	119	89	127	125	144	125	107	146	133	130
Double pump												
Available static pressure ⁽¹⁾	kPa	80	92	82	119	116	136	115	95	133	115	110
Single pump HP												
Available static pressure ⁽¹⁾	kPa	191	218	201	207	215	202	214	192	230	215	212
Double pump HP												
Available static pressure ⁽¹⁾	kPa	171	204	203	206	213	198	202	171	213	191	186
Expansion vessel												
Volume	l	50										
Maximum pressure	kPa	400										
Gross Weight	kg	12,2										

(1) : Pump external static pressure - Evaporator pressure drop

PUMP PRESSURE CURVES

*Low pressure
Single pump*

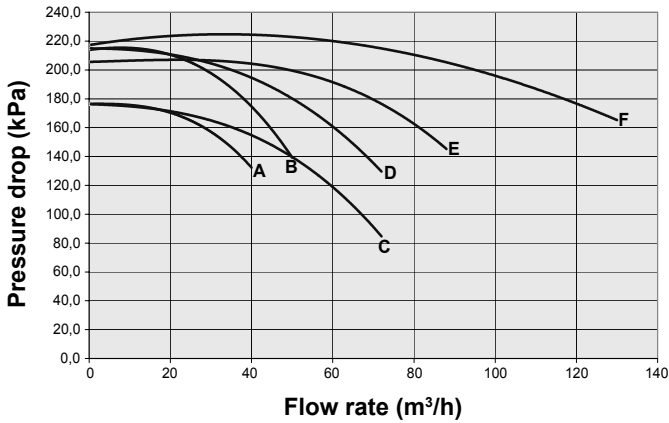

*High pressure
Single pump*

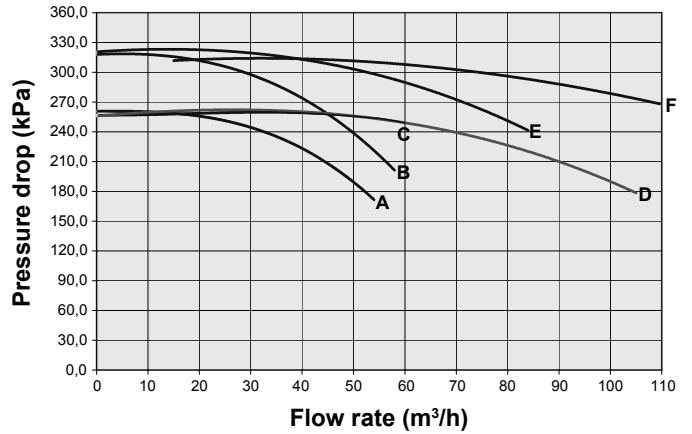

*Low pressure
Double pump*

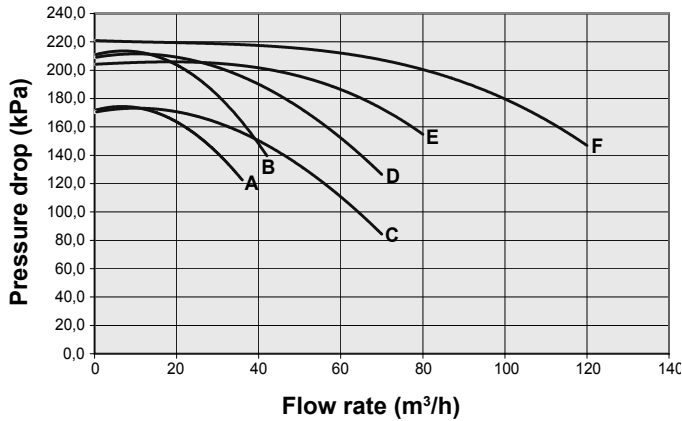

*High pressure
Double pump*

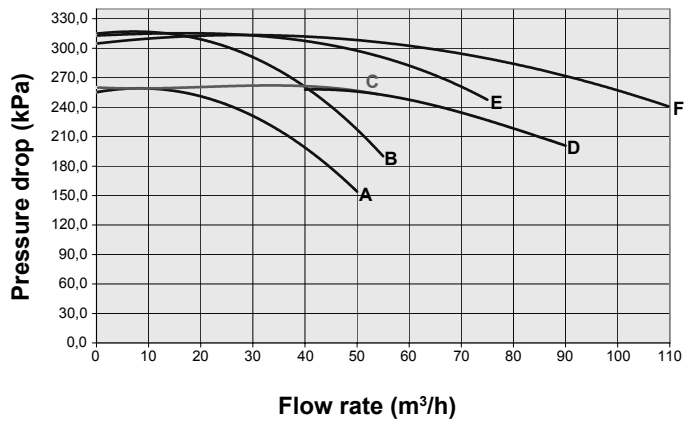

A	NAC/NAH 200	D	NAC/NAH 300/340
B	NAC/NAH 230	E	NAC/NAH 380/420/480
C	NAC/NAH 270	F	NAC 540/600/640

A	NAC/NAH 200	D	NAC/NAH 300/340/380
B	NAC/NAH 230	E	NAC/NAH 420/480
C	NAC/NAH 270	F	NAC 540/600/640

UNIT WITH HYDRAULIC MODULE

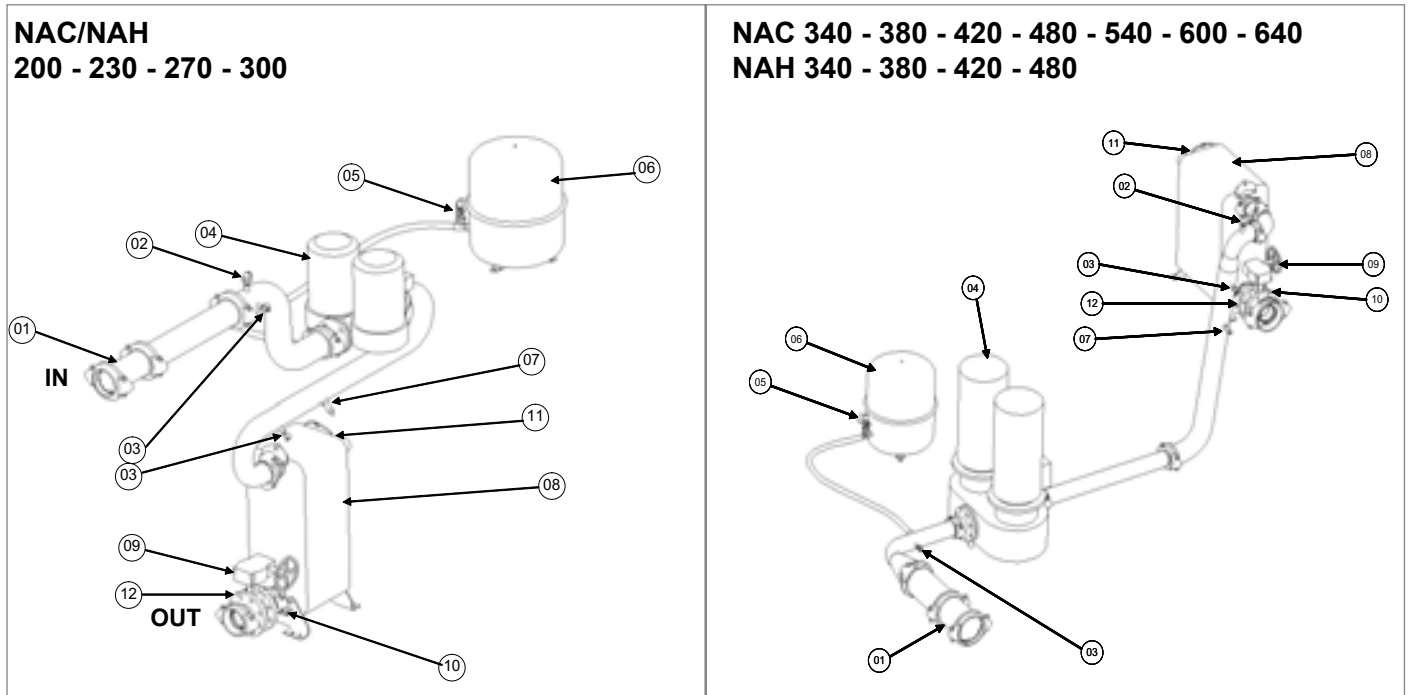

01	Water filter (item supplied loose)	07	Electronic flow switch
02	Air purge	08	Plate heat exchanger
03	Pressure tap	09	Setting valve
04	Pump	10	Pressure tap and drain valve
05	Safety valve with manometer	11	Return temperature sensor
06	Expansion vessel	12	Supply temperature sensor

MINIMUM WATER CONTENT OF AN INSTALLATION

Thanks to multi step capacity control and smart anti-short compressor cycling, NEOSYS™ can work with minimum water loop volume as defined here below. This can eliminate the need for a buffer tank in most of air-conditioning applications (e.g. NEOSYS™ application with fan-coil units). :

$$V_{mini} = 86 \times Q / (N_{stages} \times Dt)$$

Where :	V	Minimum water content of the installation
	Q	Cooling capacity of the chiller
	Nstage	Number of control steps available in the unit
	Dt	Maximum acceptable temperature rise (Dt = 6°C for an air conditioning application)

Important note: In case NEOSYS™ is used in air-conditioning applications with a short water system (e.g. NEOSYS™ application with air handling units) or in case NEOSYS™ is used for industrial process cooling, it is mandatory to use a buffer tank.

MINIMUM WATER CONTENT OF AN INSTALLATION (con't)

Unit Size	Number of stages	Mini water volume (l)
NAC		
200	6	478
230	6	549
270	6	645
300	4	1075
340	5	975
380	5	1089
420	6	1003
480	6	1147
540	6	1290
600	6	1433
640	6	1529
680	10	975
760	10	1089
840	12	1003
960	12	1147
1080	12	1290

Unit Size	Number of stages	Mini water volume (l)
NAH		
200	6	478
230	6	549
270	6	645
300	4	1075
340	5	975
380	6	908
420	6	1003
480	6	1147

MAXIMUM WATER CONTENT OF AN INSTALLATION

The maximum water content of the installation is determined by the capacity of the expansion vessel.
 On units fitted with a standard Hydraulic Module it is possible to determine the maximum water content of the installation.

Unit Size	Expansion vessel volume	Pressure in the expansion vessel	Max. volume clear water (l)		Max. volume Glycol water (l)	
			Static pressure		Static pressure	
			5 m	10 m	5 m	10 m
200-230-270 300-340-380 420-480 540 600-640	50 l	1,5 Bar	5 230 l	4 180 l	4 020 l	3 210 l

GLYCOL CORRECTION FACTOR

Minimum ambient temperature or water outlet temperature	Ethylene glycol	Pressure drop	Water flow	CAPACITIES	
				Cooling	Heating
+ 5°C ► 0°C	10%	1,05	1,02	0,99	0,994
0°C ► -5°C	20%	1,10	1,05	0,98	0,993
- 5°C ► -10°C	30%	1,15	1,08	0,97	0,99
- 10°C ► -15°C	35%	1,18	1,10	0,96	0,987

Example : 10% glycol
 Minimum flow : 1,19 m³/h x 1,02
 Pressure drop x 1,07
 System capacity x 0,99

IMPORTANT NOTE : Thanks to variable speed fans, maximum sound level can be reduced.
 NEOSYS™ maximum air flow can be adjusted between 70 % and 100 % of the nominal airflow to meet maximum sound level requirements.

NAC

Please contact LENNOX for noise level calculations at reduced airflow.

Spectrum per octave band dB(A)								Maximum global sound power	Maximum sound pressure at 10 meters envelopping surface
NAC	125 Hz	250 Hz	500 Hz	1000 Hz	2000 Hz	4000 Hz	8000 Hz	EUROVENT Lw dB(A)	(1) Lp dB(A)
200	68	79	83	85	82	75	68	89	58
230	68	80	84	85	82	76	68	89	58
270	68	80	84	85	83	76	68	89	58
300	70	82	85	87	84	78	70	91	60
340	70	82	85	87	84	78	70	91	60
380	70	82	86	87	84	78	70	91	60
420	71	83	87	88	85	79	71	92	61
480	71	83	87	88	86	79	71	92	61
540	71	83	87	89	87	80	71	93	62
600	72	83	88	90	88	81	72	94	63
640	72	83	88	90	88	81	72	94	63
680	73	85	88	90	87	81	73	94	63
760	73	85	89	90	88	81	73	94	63
840	74	86	90	91	88	82	74	95	64
960	74	86	90	91	89	82	74	95	64
1080	74	86	90	92	90	83	74	96	65

NAH

Spectrum per octave band dB(A)								Maximum global sound power	Maximum sound pressure at 10 meters envelopping surface
NAH	125 Hz	250 Hz	500 Hz	1000 Hz	2000 Hz	4000 Hz	8000 Hz	EUROVENT Lw dB(A)	(1) Lp dB(A)
200	68	79	83	85	82	75	68	89	58
230	68	80	84	85	82	76	68	89	58
270	70	82	85	87	84	78	70	91	60
300	70	82	85	87	84	78	70	91	60
340	70	82	85	87	84	78	70	91	60
380	71	83	87	88	85	79	71	92	61
420	71	83	87	88	85	79	71	92	61
480	71	83	87	88	86	79	71	92	61

(1) : For information only: Data calculated by enveloping surface method in free open field.

Enveloping Surface

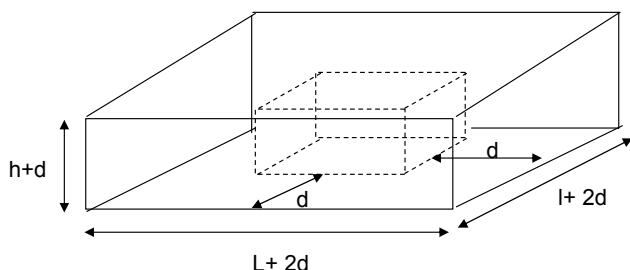

$$A = 2(L+2d)(h+d) + 2(l+2d)(h+d) + (L+2d)(l+2d)$$

NAC

NAC		200 > 340	380	420 - 480	540	600 > 680	760	840 - 960	1080
Min. outlet water temperature	°C	5							
Min. outlet water temperature with brine operation option	°C	- 10							
Max. inlet water temperature	°C	20							
Min. difference water inlet/outlet	°C	3							
Max. difference water inlet/outlet	°C	8							
Min. outside air temperature	°C	6							
Min. outside air temperature Winter operation option	°C	- 20							
Maximum outside air temperature : Full capacity operation	°C	46	43	46	43	46	43	46	43

NAH

Cooling mode	NAH	200 > 480
Min. outlet water temperature	°C	5
Max. inlet water temperature	°C	20
Min. difference water inlet/outlet	°C	3
Max. difference water inlet/outlet	°C	8
Min. outside air temperature	°C	6
Maximum outside air temperature : Full capacity operation	°C	46

Heating mode	NAH	200 > 480
Min. condenser outlet water temperature	°C	24
Max. condenser outlet water temperature	°C	50
Min. difference water inlet/outlet	°C	3
Max. difference water inlet/outlet	°C	8
Min. outside air temperature (Water outlet temp. : 37°C)	°C	- 12
Max. outside air temperature	°C	30

NAC
Operating envelope
Cooling mode

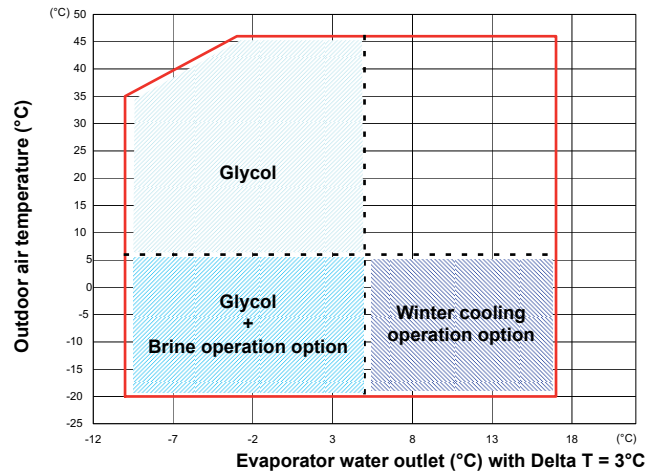

Maximum outdoor air temperature = 43°C on NAC 380 / NAC 540 and NAC 1080

NAH
Operating envelope
Cooling mode

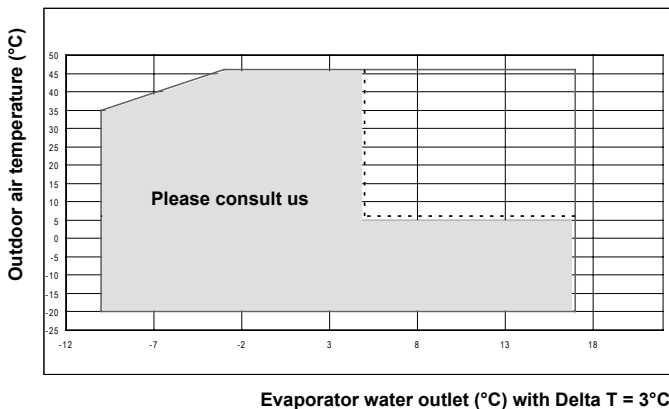

NAH
Operating envelope
Heating mode

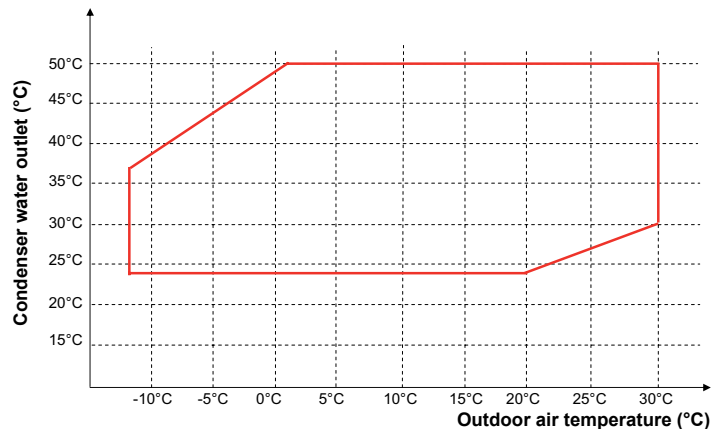

UNITS

NAC

NEOSYS™		200	230	270	300	340	380	420	480	540	600	640
Minimum and maximum voltage	V	380 V / 420 V										
Maximum power	kW	96,1	113,7	134,5	146,5	165,1	191,5	204,6	231,0	262,8	297,8	297,8
Maximum current	A	170,6	199,4	227,7	249,3	280,2	323,4	347,0	390,3	433,8	484,5	484,5
Maximum current (with cos phi 0,95 option)	A	152,9	179,7	211,3	231,8	260,3	300,4	322,7	362,8	411,2	466,7	466,7
Start-up intensity	A	397,7	450,1	478,4	500,0	530,9	574,1	597,8	641,0	754,0	804,7	804,7
Start-up intensity (with sofstarter option)	A	288,9	326,1	354,4	376,0	406,9	450,1	473,8	517,0	596,3	647,0	647,0
Start-up intensity (with cos phi 0,95 option)	A	274,6	310,8	342,4	363,0	391,5	431,6	453,9	494,0	576,6	632,1	632,1
Maximum connectable power section	mm ²	185	185	185	300	300	300	300	300	300	300	300

UNITS (dual connection point)

NEOSYS™		680	760	840	960	1080
Minimum and maximum voltage		380 V / 420 V				
Maximum power per box	kW	165,1	191,5	204,6	231,0	262,8
Maximum current per box	A	280,2	323,4	347,0	390,3	433,8
Maximum current per box (with cos phi 0,95 option)	A	260,3	300,4	322,7	362,8	411,2
Start-up intensity per box	A	530,9	574,1	597,8	641,0	754,0
Start-up intensity per box (with sofstarter option)	A	406,9	450,1	473,8	517,0	596,3
Start-up intensity per box (with cos phi 0,95 option)	A	391,5	431,6	453,9	494,0	576,6

UNITS (single main power connection as an option)

NEOSYS™		680	760	840	960	1080
Minimum and maximum voltage	V	380 V / 420 V				
Maximum power	kW	330,2	383,0	409,1	461,9	525,5
Maximum current	A	560,3	646,8	694,1	780,5	867,5
Maximum current (with cos phi 0,95 option)	A	520,6	600,8	645,5	725,7	822,3
Start-up intensity	A	811,0	897,5	944,8	1031,2	1187,7
Start-up intensity (with sofstarter option)	A	687,0	773,4	820,8	907,2	1030,1
Start-up intensity (with cos phi 0,95 option)	A	651,8	732,0	776,6	856,8	987,8

OPTIONS

NAC

NEOSYS™			200	230	270	300	340	380	420	480	540	600	640
Low pressure	Single pump	kW	2,20	3,00	3,00	4,00	4,00	5,50	5,50	5,50	7,50	7,50	7,50
	Double pump												
High pressure	Single pump - Double pump	A	5,00	6,10	6,10	7,50	7,50	10,50	10,50	10,50	13,80	13,80	13,80
	Maximum current												
Evaporator anti-freeze heater *		kW	0,13										
Evaporator anti-freeze heater Maximum current		A	0,32										
Hydraulic anti-freeze heater		kW	0,23	0,23	0,23	0,23	0,24	0,24	0,24	0,24	0,24	0,24	0,24
Hydraulic anti-freeze heater Maximum current		A	0,56	0,56	0,56	0,56	0,60	0,60	0,60	0,60	0,60	0,60	0,60

* : Value x 2 if desuperheater

OPTIONS (dual connection point)

NEOSYS™		680	760	840	960	1080
Evaporator anti-freeze heater power per box	kW	0,13				
Evaporator anti-freeze heater Maximum current per box	A	0,32				
Hydraulic anti-freeze heater power per box	kW	0,48				
Hydraulic anti-freeze heater Maximum current per box	A	1,20				

OPTIONS (single main power connection as an option)

NEOSYS™		680	760	840	960	1080
Evaporator anti-freeze heater power	kW	0,26				
Evaporator anti-freeze heater Maximum current	A	0,65				
Hydraulic anti-freeze heater power	kW	0,96				
Hydraulic anti-freeze heater Maximum current	A	2,40				

UNITS

NAH

NEOSYS™		200	230	270	300	340	380	420	480
Minimum and maximum voltage	V	380 V / 420 V							
Maximum power	kW	96,1	113,7	137,7	155,3	165,1	194,7	204,6	231,0
Maximum current	A	170,6	199,4	234,9	263,7	280,2	330,6	347,0	390,3
Maximum current (with cos phi 0,95 option)	A	152,9	179,7	218,5	245,2	260,3	307,6	322,7	362,8
Start-up intensity	A	397,7	450,1	485,6	514,4	530,9	581,3	597,8	641,0
Start-up intensity (with sofstarter option)	A	288,9	326,1	361,6	390,4	406,9	457,3	473,8	517,0
Start-up intensity (with cos phi 0,95 option)	A	274,6	310,8	349,6	376,3	391,5	438,8	453,9	494,0
Maximum connectable power section	mm ²	185	185	185	300	300	300	300	300

OPTIONS

NEOSYS™		200	230	270	300	340	380	420	480	
Low pressure	Single pump Double pump	kW	2,20	3,00	3,00	4,00	4,00	5,50	5,50	5,50
	Single pump - Double pump Maximum current	A	5,00	6,00	6,00	8,05	8,05	10,50	10,50	13,80
High pressure	Single pump Double pump	kW	4,00	5,50	5,50	7,50	7,50	7,50	7,50	7,50
	Single pump - Double pump Maximum current	A	8,05	10,50	10,50	14,30	14,30	14,30	14,30	14,3
Evaporator anti-freeze heater *	kW	0,13								
Evaporator anti-freeze heater Maximum current	A	0,32								
Hydraulic anti-freeze heater	kW	0,23	0,23	0,23	0,23	0,34	0,34	0,34	0,34	
Hydraulic anti-freeze heater Maximum current	A	0,56	0,56	0,56	0,56	0,84	0,84	0,84	0,84	

* : Value x 2 if desuperheater

COOLING CAPACITIES

NAC		Outdoor air temperature																
		28				30				32				35				
		Pf	Pe	Wf	Dp	Pf	Pe	Wf	Dp	Pf	Pe	Wf	Dp	Pf	Pe	Wf	Dp	
		kW	kW	m³/h	kPa	kW	kW	m³/h	kPa	kW	kW	m³/h	kPa	kW	kW	m³/h	kPa	
Water outlet temperature	5 °C	200	212,2	63,3	36,5	44,6	207,8	65,4	35,8	42,9	203,2	67,6	35,0	41,1	196,1	71,1	33,7	38,5
		230	240,9	75,0	41,4	56,3	235,8	77,4	40,6	54,1	230,5	80,1	39,6	51,9	222,1	84,4	38,2	48,5
		270	280,1	93,1	48,2	58,7	273,9	96,2	47,1	56,3	267,5	99,5	46,0	53,9	257,5	104,9	44,3	50,1
		300	313,1	94,0	53,9	49,7	306,6	97,0	52,7	47,8	299,9	100,2	51,6	45,9	289,4	105,5	49,8	43,0
		340	359,2	110,2	61,8	36,1	351,5	113,8	60,5	34,7	343,5	117,6	59,1	33,3	331,0	123,8	56,9	31,1
		380	397,2	130,0	68,3	43,5	388,5	134,3	66,8	41,8	379,4	138,9	65,3	40,0	365,3	146,6	62,9	37,3
		420	437,8	133,7	75,3	52,1	428,6	138,0	73,7	50,1	419,2	142,6	72,1	48,1	404,4	150,2	69,6	45,0
		480	497,4	152,4	85,6	50,2	487,9	157,4	83,9	48,5	478,1	162,8	82,3	46,6	462,6	171,8	79,6	43,9
		540	540,5	176,6	93,0	58,6	530,3	182,0	91,2	56,6	519,7	188,1	89,4	54,5	502,6	198,5	86,5	51,2
		600	614,3	193,4	105,7	60,8	603,3	198,8	103,8	58,7	591,6	205,1	101,8	56,6	572,9	216,0	98,6	53,2
		640	636,8	199,5	109,5	60,2	625,2	205,1	107,6	58,1	613,0	211,6	105,5	56,0	593,5	222,8	102,1	52,7
		680	718,5	220,4	123,6	45,0	703,0	227,5	120,9	43,2	687,0	235,2	118,2	41,4	662,0	247,6	113,9	38,6
	760	794,4	260,1	136,7	54,3	777,0	268,5	133,7	52,1	758,9	277,8	130,6	49,8	730,7	293,1	125,7	46,4	
	840	875,6	267,3	150,6	67,4	857,3	276,0	147,5	64,8	838,4	285,3	144,2	62,1	808,9	300,5	139,2	58,1	
	960	994,8	304,8	171,1	68,5	975,9	314,8	167,9	66,0	956,2	325,6	164,5	63,5	925,2	343,5	159,2	59,7	
	1080	1081	353,2	186,0	80,1	1061	364,0	182,5	77,3	1039	376,2	178,8	74,3	1005,2	397,0	172,9	69,8	
	6 °C	200	218,8	63,8	37,6	47,1	214,2	65,9	36,9	45,3	209,5	68,1	36,0	43,5	202,1	71,6	34,8	40,7
		230	248,4	75,6	42,7	59,6	243,0	78,1	41,8	57,3	237,5	80,7	40,9	54,9	228,9	85,1	39,4	51,3
		270	288,5	93,9	49,6	62,0	282,1	97,0	48,5	59,5	275,5	100,3	47,4	56,9	265,1	105,7	45,6	53,0
		300	323,0	94,6	55,6	52,6	316,2	97,7	54,4	50,6	309,3	100,9	53,2	48,6	298,4	106,2	51,3	45,5
		340	370,3	111,1	63,7	38,2	362,3	114,6	62,3	36,7	354,0	118,5	60,9	35,2	341,1	124,7	58,7	32,8
		380	409,3	131,2	70,4	46,0	400,3	135,5	68,9	44,2	390,9	140,1	67,3	42,3	376,3	147,8	64,7	39,4
		420	451,4	134,6	77,7	55,2	442,0	139,0	76,0	53,0	432,2	143,6	74,4	50,9	416,9	151,3	71,7	47,6
		480	512,3	153,6	88,1	53,1	502,5	158,6	86,5	51,2	492,3	164,0	84,7	49,3	476,3	173,0	81,9	46,3
		540	555,9	177,9	95,6	61,8	545,4	183,4	93,8	59,6	534,4	189,6	91,9	57,4	516,8	200,2	88,9	53,9
		600	631,5	194,6	108,7	64,0	620,2	200,1	106,7	61,9	608,2	206,5	104,6	59,6	589,0	217,5	101,3	56,1
		640	654,6	200,6	112,6	63,4	642,7	206,4	110,6	61,3	630,2	213,0	108,4	59,0	610,2	224,5	105,0	55,5
		680	740,6	222,1	127,4	47,6	724,6	229,2	124,7	45,7	708,0	236,9	121,8	43,8	682,1	249,4	117,4	40,8
	760	818,7	262,5	140,8	57,4	800,5	271,0	137,7	55,1	781,8	280,3	134,5	52,7	752,6	295,6	129,5	49,1	
	840	902,9	269,3	155,3	71,4	883,9	277,9	152,1	68,6	864,3	287,3	148,7	65,8	833,8	302,5	143,5	61,5	
	960	1025	307,1	176,3	72,4	1005	317,2	172,9	69,8	984,6	328,1	169,4	67,1	952,5	346,0	163,9	63,1	
	1080	1112	355,9	191,3	84,4	1091	366,9	187,7	81,4	1069	379,2	183,9	78,4	1033,6	400,4	177,8	73,6	
	7 °C	200	225,5	64,3	38,8	49,8	220,7	66,3	38,0	47,9	215,8	68,5	37,1	46,0	208,2	72,1	35,8	43,0
		230	255,9	76,3	44,0	63,0	250,4	78,7	43,1	60,5	244,6	81,4	42,1	58,0	235,7	85,7	40,6	54,1
		270	297,0	94,8	51,1	65,5	290,4	97,9	50,0	62,8	283,5	101,2	48,8	60,0	272,8	106,7	46,9	55,9
		300	333,0	95,3	57,3	55,7	326,0	98,3	56,1	53,5	318,8	101,6	54,8	51,4	307,6	106,9	52,9	48,1
340		381,5	111,9	65,6	40,4	373,2	115,5	64,2	38,8	364,6	119,4	62,7	37,2	351,3	125,6	60,4	34,7	
380		421,5	132,5	72,5	48,6	412,1	136,7	70,9	46,6	402,4	141,4	69,2	44,6	387,3	149,1	66,6	41,6	
420		465,3	135,6	80,0	58,3	455,5	140,0	78,4	56,1	445,3	144,7	76,6	53,8	429,6	152,3	73,9	50,3	
480		527,2	154,8	90,7	56,0	517,0	159,8	89,0	54,0	506,5	165,3	87,1	51,9	489,9	174,3	84,3	48,8	
540		571,2	179,3	98,3	65,0	560,4	184,9	96,4	62,7	549,0	191,2	94,5	60,4	530,9	201,9	91,3	56,7	
600		648,7	195,7	111,6	67,4	637,0	201,4	109,6	65,1	624,7	207,9	107,5	62,7	605,0	219,1	104,1	59,0	
640		672,4	201,8	115,7	66,7	660,2	207,7	113,6	64,5	647,4	214,4	111,4	62,1	626,9	226,1	107,9	58,4	
680		763,0	223,9	131,3	50,3	746,4	231,0	128,4	48,3	729,2	238,7	125,5	46,3	702,6	251,3	120,9	43,2	
760	843,1	264,9	145,0	60,7	824,3	273,5	141,8	58,2	804,9	282,8	138,5	55,6	774,7	298,2	133,3	51,8		
840	930,6	271,3	160,1	75,5	910,9	280,0	156,7	72,6	890,6	289,3	153,2	69,6	859,1	304,6	147,8	65,0		
960	1054	309,6	181,4	76,4	1034	319,7	177,9	73,6	1013	330,6	174,3	70,8	979,8	348,7	168,6	66,5		
1080	1142	358,6	196,6	88,9	1121	369,8	192,8	85,7	1098	382,4	188,9	82,5	1061,9	403,8	182,7	77,4		

Pf : <i>Net cooling capacity in kW</i>	Pe : <i>Effective absorbed power in cooling mode</i>	Wf : <i>Water flow in m³ per hour</i>	Dp : <i>Water pressure drop in KPa</i>
--------------------------------------------------	----------------------------------------------------------------	-------------------------------------------------	--------------------------------------------------

COOLING MODE

NAH		Outdoor air temperature																
		28°C				30°C				32°C				35°C				
		Pf	Pe	Wf	Dp	Pf	Pe	Wf	Dp	Pf	Pe	Wf	Dp	Pf	Pe	Wf	Dp	
		kW	kW	m³/h	kPa	kW	kW	m³/h	kPa	kW	kW	m³/h	kPa	kW	kW	m³/h	kPa	
Water outlet temperature	5°C	200	196,0	64,0	33,7	38,4	191,5	66,3	32,9	36,8	186,9	68,6	32,2	35,2	179,9	72,4	30,9	32,8
		230	223,3	75,0	38,4	48,9	218,0	77,7	37,5	46,8	212,6	80,6	36,6	44,7	204,5	85,2	35,2	41,6
		270	277,0	92,9	47,7	57,5	270,9	96,2	46,6	55,1	264,6	99,7	45,5	52,7	254,9	105,2	43,9	49,2
		300	303,2	101,4	52,2	46,9	296,1	105,1	50,9	44,9	289,0	109,0	49,7	42,9	278,1	115,3	47,9	40,0
		340	334,0	111,4	57,5	31,6	325,8	115,5	56,1	30,2	317,5	119,8	54,6	28,8	305,0	126,4	52,5	26,7
		380	370,3	115,8	63,7	38,2	361,8	120,0	62,2	36,6	353,1	124,4	60,8	35,0	339,8	131,3	58,5	32,6
		420	408,7	134,3	70,3	45,9	399,0	139,3	68,6	43,9	389,2	144,6	67,0	41,9	374,3	152,8	64,4	39,0
		480	465,5	154,5	80,1	44,4	455,0	160,5	78,3	42,5	444,5	166,7	76,5	40,7	428,5	176,5	73,7	38,0
	6°C	200	201,9	64,6	34,7	40,6	197,3	66,9	33,9	38,9	192,6	69,2	33,1	37,2	185,4	73,0	31,9	34,7
		230	229,9	75,8	39,6	51,7	224,5	78,5	38,6	49,4	219,0	81,4	37,7	47,2	210,7	85,9	36,2	44,0
		270	285,6	93,7	49,1	60,9	279,3	97,0	48,0	58,4	272,8	100,4	46,9	55,9	262,9	106,0	45,2	52,1
		300	312,3	102,4	53,7	49,5	305,1	106,1	52,5	47,4	297,8	109,9	51,2	45,4	286,7	116,1	49,3	42,3
		340	344,0	112,4	59,2	33,4	335,5	116,5	57,7	31,9	327,1	120,8	56,3	30,4	314,3	127,4	54,1	28,2
		380	381,6	116,7	65,7	40,4	372,9	120,9	64,1	38,7	363,9	125,3	62,6	37,0	350,3	132,2	60,3	34,5
		420	421,1	135,5	72,5	48,5	411,1	140,5	70,7	46,4	401,1	145,7	69,0	44,3	385,8	153,9	66,4	41,2
		480	478,9	156,0	82,4	46,8	468,2	162,0	80,5	44,9	457,4	168,2	78,7	42,9	441,1	177,9	75,9	40,1
	7°C	200	207,9	65,2	35,8	42,9	203,2	67,5	35,0	41,1	198,4	69,8	34,1	39,3	191,0	73,5	32,9	36,7
		230	236,6	76,7	40,7	54,5	231,1	79,4	39,8	52,2	225,5	82,2	38,8	49,9	217,0	86,7	37,3	46,4
		270	294,4	94,5	50,6	64,4	287,8	97,8	49,5	61,7	281,2	101,2	48,4	59,1	271,0	106,7	46,6	55,2
		300	321,6	103,4	55,3	52,2	314,2	107,0	54,1	50,0	306,7	110,9	52,8	47,9	295,4	117,0	50,8	44,7
		340	354,0	113,5	60,9	35,2	345,4	117,6	59,4	33,6	336,7	121,8	57,9	32,1	323,6	128,4	55,7	29,8
		380	393,1	117,7	67,6	42,7	384,1	121,8	66,1	40,9	374,9	126,2	64,5	39,1	360,9	133,1	62,1	36,5
		420	433,6	136,7	74,6	51,2	423,4	141,7	72,8	49,0	413,1	146,9	71,1	46,8	397,5	155,1	68,4	43,6
		480	492,2	157,6	84,7	49,2	481,3	163,5	82,8	47,2	470,3	169,7	80,9	45,2	453,7	179,4	78,1	42,3

Pf : Net cooling capacity in kW	Pe : Effective absorbed power in cooling mode	Wf : Water flow in m³ per hour	Dp : Water pressure drop in KPa
-------------------------------------------	---------------------------------------------------------	------------------------------------------	-------------------------------------------

HEATING MODE

NAH		Water outlet temperature																
		30°C				35°C				40°C				45°C				
		Pf	Pe	Wf	Dp	Pf	Pe	Wf	Dp	Pf	Pe	Wf	Dp	Pf	Pe	Wf	Dp	
		kW	kW	m³/h	kPa	kW	kW	m³/h	kPa	kW	kW	m³/h	kPa	kW	kW	m³/h	kPa	
Outdoor air temperature	20°C	200	322,6	55,8	55,5	96,8	315,9	61,0	54,4	93,1	308,7	66,8	53,1	89,2	301,1	73,2	51,8	85,1
		230	369,2	65,4	63,5	124,2	362,0	71,9	62,3	119,8	354,3	79,0	61,0	115,1	346,0	86,7	59,5	110,1
		270	464,7	82,7	79,9	151,2	452,6	90,3	77,9	143,9	441,0	98,9	75,9	137,1	429,8	108,6	74,0	130,7
		300	511,3	90,7	88,0	122,2	498,6	99,3	85,8	116,7	486,5	108,9	83,7	111,5	474,8	119,5	81,7	106,7
		340	546,8	96,7	94,1	78,7	534,3	105,3	91,9	75,4	522,2	115,1	89,8	72,2	510,6	126,3	87,8	69,3
		380	609,2	107,6	104,8	96,1	594,1	116,9	102,2	91,7	579,3	127,7	99,7	87,5	565,0	139,9	97,2	83,6
		420	680,1	122,0	117,0	117,8	663,6	132,8	114,2	112,6	647,7	145,3	111,4	107,6	632,3	159,3	108,8	102,9
		480	753,4	134,5	129,6	109,0	735,8	146,4	126,6	104,3	718,9	160,1	123,7	99,9	702,7	175,6	120,9	95,7
	15°C	200	284,5	54,6	48,9	76,7	279,1	59,8	48,0	74,0	273,1	65,6	47,0	71,1	266,7	72,0	45,9	68,0
		230	324,9	63,6	55,9	98,0	319,3	70,2	54,9	94,9	313,2	77,4	53,9	91,6	306,4	85,1	52,7	88,0
		270	409,2	80,9	70,4	119,2	399,3	88,4	68,7	113,9	389,8	97,1	67,1	108,8	380,7	106,8	65,5	104,2
		300	449,7	88,3	77,4	96,6	439,5	97,0	75,6	92,6	429,7	106,6	73,9	88,8	420,5	117,3	72,3	85,4
		340	480,4	94,6	82,7	61,9	470,2	103,2	80,9	59,5	460,5	113,1	79,2	57,2	451,1	124,4	77,6	55,1
		380	536,3	105,6	92,3	75,9	523,7	115,0	90,1	72,6	511,5	125,7	88,0	69,5	499,6	137,9	86,0	66,6
		420	597,6	119,1	102,8	92,7	584,2	130,0	100,5	88,9	571,4	142,6	98,3	85,3	559,1	156,7	96,2	82,0
		480	661,0	130,7	113,7	85,4	646,9	142,9	111,3	82,0	633,5	156,9	109,0	78,9	620,9	172,7	106,8	76,0
	10°C	200	249,9	53,5	43,0	60,3	245,7	58,7	42,3	58,4	241,0	64,5	41,5	56,4	235,8	71,0	40,6	54,2
		230	284,9	62,1	49,0	76,8	280,9	68,8	48,3	74,9	276,3	76,0	47,5	72,6	271,1	83,8	46,6	70,1
		270	359,1	79,3	61,8	93,4	351,2	86,8	60,4	89,6	343,8	95,5	59,1	86,1	336,8	105,2	57,9	82,8
		300	394,1	86,3	67,8	75,8	386,3	95,0	66,5	73,1	378,9	104,8	65,2	70,5	372,2	115,5	64,0	68,2
		340	420,6	92,7	72,4	48,4	412,7	101,3	71,0	46,7	405,3	111,3	69,7	45,2	398,2	122,6	68,5	43,7
		380	470,4	103,8	80,9	59,5	460,3	113,1	79,2	57,2	450,6	123,8	77,5	55,0	441,2	135,9	75,9	52,9
		420	523,2	116,6	90,0	72,5	512,9	127,6	88,2	69,9	503,2	140,2	86,6	67,4	494,0	154,5	85,0	65,2
		480	577,9	127,5	99,4	66,5	567,3	140,0	97,6	64,2	557,5	154,2	95,9	62,1	548,4	170,3	94,3	60,3
	7°C	200	230,8	52,9	39,7	52,1	227,4	58,1	39,1	50,6	223,5	63,9	38,4	49,0	219,0	70,4	37,68	47,2
		230	262,9	61,3	45,2	66,2	259,8	68,0	44,7	64,8	256,2	75,3	44,1	63,1	252,0	83,2	43,35	61,2
		270	331,5	78,4	57,0	80,4	324,9	86,0	55,9	77,4	318,7	94,6	54,8	74,7	313,0	104,3	53,84	72,2
		300	363,6	85,3	62,6	65,4	357,2	94,0	61,5	63,3	351,3	103,8	60,4	61,4	346,0	114,6	59,53	59,7
		340	387,9	91,6	66,7	41,7	381,4	100,3	65,6	40,4	375,3	110,3	64,6	39,2	369,7	121,7	63,60	38,1
		380	434,2	102,7	74,7	51,3	425,6	112,0	73,2	49,5	417,4	122,7	71,8	47,7	409,5	134,8	70,45	46,1
		420	482,6	115,2	83,0	62,4	474,1	126,3	81,6	60,4	466,2	139,0	80,2	58,6	458,9	153,3	78,94	56,9
		480	532,5	125,9	91,6	57,0	524,0	138,5	90,2	55,4	516,3	153,0	88,8	53,9	509,3	169,2	87,63	52,5
5°C	200	218,8	52,5	37,6	47,2	215,9	57,7	37,1	46,0	212,4	63,5	36,6	44,6	208,5	70,0	35,9	43,1	
	230	249,1	60,8	42,9	59,9	246,7	67,6	42,4	58,9	243,7	74,9	41,9	57,5	240,1	82,8	41,3	56,0	
	270	314,1	77,9	54,0	72,7	308,3	85,4	53,0	70,2	303,0	94,1	52,1	68,0	298,1	103,8	51,3	65,9	
	300	344,4	84,7	59,3	59,2	339,0	93,5	58,3	57,5	334,1	103,3	57,5	56,0	329,7	114,1	56,7	54,7	
	340	367,4	91,0	63,2	37,7	361,8	99,7	62,2	36,6	356,7	109,7	61,4	35,7	351,9	121,1	60,5	34,8	
	380	411,5	102,1	70,8	46,5	403,9	111,3	69,5	44,9	396,6	121,9	68,2	43,4	389,8	134,0	67,1	42,0	
	420	457,1	114,4	78,6	56,4	449,9	125,5	77,4	54,8	443,2	138,2	76,2	53,3	437,1	152,6	75,2	52,0	
	480	504,1	125,0	86,7	51,5	497,0	137,7	85,5	50,2	490,7	152,2	84,4	49,0	485,2	168,5	83,5	47,9	
0°C	200	191,3	51,5	32,9	36,8	189,6	56,8	32,6	36,2	187,4	62,6	32,2	35,4	184,7	69,1	31,8	34,4	
	230	217,6	59,8	37,4	46,7	216,7	66,7	37,3	46,3	215,3	74,1	37,0	45,8	213,3	82,1	36,7	45,0	
	270	274,4	76,7	47,2	56,4	270,7	84,3	46,6	55,1	267,5	92,9	46,0	53,8	264,7	102,6	45,5	52,8	
	300	300,7	83,5	51,7	46,2	297,7	92,4	51,2	45,3	295,3	102,2	50,8	44,6	293,3	113,1	50,5	44,1	
	340	320,7	89,5	55,2	29,3	317,5	98,3	54,6	28,8	314,6	108,4	54,1	28,3	312,2	119,8	53,7	27,9	
	380	359,5	100,4	61,9	36,2	354,4	109,6	61,0	35,3	349,7	120,2	60,2	34,4	345,3	132,2	59,4	33,6	
	420	399,1	112,6	68,7	43,9	395,0	123,8	68,0	43,1	391,4	136,6	67,3	42,4	388,3	151,1	66,8	41,7	
	480	439,6	123,0	75,6	39,9	436,0	136,0	75,0	39,3	433,3	150,8	74,5	38,8	431,2	167,3	74,2	38,5	

Ph : Net heating capacity in kW - Instantaneous heating capacity (this does not take into account the formation of frost on the coil and the defrost cycles.	Pe : Effective absorbed power in heating mode	Wf : Water flow in m³ per hour	Dp : Water pressure drop in KPa
------------------------------------------------------------------------------------------------------------------------------------------------------------------------------------	------------------------------------------------------------	------------------------------------------	-------------------------------------------

HEATING MODE

NAH		Water outlet temperature																
		30°C				35°C				40°C				45°C				
		Pf	Pe	Wf	Dp	Pf	Pe	Wf	Dp	Pf	Pe	Wf	Dp	Pf	Pe	Wf	Dp	
		kW	kW	m³/h	kPa	kW	kW	m³/h	kPa	kW	kW	m³/h	kPa	kW	kW	m³/h	kPa	
Outdoor air temperature	-2°C	200	181,2	51,2	31,2	33,3	180,1	56,4	31,0	32,9	178,4	62,3	30,7	32,3	176,1	68,8	30,3	31,6
		230	206,2	59,5	35,5	42,2	206,0	66,4	35,4	42,2	205,2	73,9	35,3	41,9	203,8	81,8	35,1	41,3
		270	259,9	76,3	44,7	51,0	257,1	83,8	44,2	50,0	254,7	92,5	43,8	49,1	252,7	102,2	43,5	48,4
		300	284,9	83,1	49,0	41,8	282,9	92,0	48,7	41,3	281,4	101,9	48,4	40,9	280,4	112,8	48,2	40,6
		340	303,9	89,0	52,3	26,5	301,6	97,8	51,9	26,1	299,6	107,9	51,6	25,8	298,1	119,4	51,3	25,6
		380	340,7	99,8	58,6	32,8	336,6	108,9	57,9	32,0	332,8	119,5	57,3	31,4	329,5	131,5	56,7	30,8
		420	378,2	111,9	65,1	39,8	375,3	123,2	64,6	39,2	372,9	136,1	64,2	38,7	371,1	150,6	63,8	38,4
		480	416,3	122,4	71,6	36,0	414,2	135,4	71,3	35,7	412,9	150,3	71,0	35,5	412,2	167,0	70,9	35,4
	-4°C	200	171,8	50,8	29,6	30,1	171,1	56,1	29,4	29,9	169,9	62,0	29,2	29,5	168,2	68,4	28,9	29,0
		230	195,5	59,3	33,6	38,3	195,9	66,2	33,7	38,4	195,7	73,7	33,7	38,4	-	-	-	-
		270	246,3	75,9	42,4	46,1	244,3	83,5	42,0	45,5	242,8	92,1	41,8	44,9	-	-	-	-
		300	270,1	82,9	46,5	37,9	269,0	91,8	46,3	37,6	268,5	101,7	46,2	37,5	-	-	-	-
		340	288,1	88,5	49,6	24,0	286,7	97,3	49,3	23,8	285,7	107,5	49,2	23,7	-	-	-	-
		380	323,0	99,1	55,6	29,7	319,9	108,3	55,0	29,2	317,1	118,9	54,6	28,7	314,7	130,9	54,1	28,3
		420	358,6	111,3	61,7	36,0	356,9	122,6	61,4	35,7	355,8	135,6	61,2	35,5	-	-	-	-
		480	394,6	121,8	67,9	32,6	393,9	135,0	67,8	32,5	394,0	150,0	67,8	32,5	-	-	-	-
	-6°C	200	162,9	50,5	28,0	27,3	162,7	55,8	28,0	27,2	162,0	61,7	27,9	27,0	-	-	-	-
		230	185,4	59,1	31,9	34,7	186,5	66,0	32,1	35,1	186,9	73,5	32,2	35,2	-	-	-	-
		270	233,5	75,6	40,2	41,8	232,4	83,1	40,0	41,4	231,7	91,8	39,9	41,2	-	-	-	-
		300	256,2	82,6	44,1	34,4	256,1	91,6	44,1	34,4	256,5	101,5	44,1	34,5	-	-	-	-
		340	273,4	88,0	47,0	21,8	272,9	96,9	47,0	21,7	272,8	107,1	46,9	21,7	-	-	-	-
		380	306,4	98,5	52,7	26,9	304,3	107,6	52,3	26,6	302,5	118,2	52,0	26,3	-	-	-	-
		420	340,3	110,8	58,5	32,7	339,9	122,2	58,5	32,6	340,0	135,1	58,5	32,6	-	-	-	-
		480	374,4	121,4	64,4	29,5	375,1	134,7	64,5	29,7	376,5	149,8	64,8	29,9	-	-	-	-
	-8°C	200	154,5	50,2	26,6	24,8	154,8	55,5	26,6	24,8	154,6	61,4	26,6	24,8	-	-	-	-
		230	176,1	58,9	30,3	31,5	177,7	65,9	30,6	32,1	-	-	-	-	-	-	-	-
		270	221,6	75,3	38,1	37,9	221,3	82,8	38,1	37,8	221,4	91,5	38,1	37,8	-	-	-	-
		300	243,2	82,5	41,8	31,3	244,1	91,5	42,0	31,5	-	-	-	-	-	-	-	-
		340	259,7	87,6	44,7	19,8	260,2	96,5	44,8	19,9	261,0	106,7	44,9	20,0	-	-	-	-
		380	290,9	97,9	50,1	24,5	289,8	107,0	49,9	24,3	289,0	117,6	49,7	24,2	-	-	-	-
		420	323,3	110,4	55,6	29,7	324,1	121,7	55,8	29,9	325,5	134,7	56,0	30,1	-	-	-	-
		480	355,6	121,0	61,2	26,8	357,8	134,4	61,5	27,1	360,6	149,6	62,0	27,6	-	-	-	-
	-10°C	200	146,7	49,9	25,2	22,5	147,5	55,2	25,4	22,7	-	-	-	-	-	-	-	-
		230	167,4	58,8	28,8	28,7	169,7	65,8	29,2	29,5	-	-	-	-	-	-	-	-
		270	210,5	75,0	36,2	34,4	211,1	82,6	36,3	34,6	-	-	-	-	-	-	-	-
		300	231,2	82,4	39,8	28,5	233,0	91,4	40,1	28,9	-	-	-	-	-	-	-	-
340		247,1	87,2	42,5	18,1	248,5	96,1	42,7	18,3	-	-	-	-	-	-	-	-	
380		276,5	97,3	47,6	22,3	276,4	106,4	47,6	22,2	276,6	117,0	47,6	22,3	-	-	-	-	
420		307,7	109,9	52,9	27,1	309,7	121,4	53,3	27,5	-	-	-	-	-	-	-	-	
480		338,4	120,8	58,2	24,5	341,9	134,3	58,8	24,9	-	-	-	-	-	-	-	-	

Ph : Net heating capacity in kW - Instantaneous heating capacity (this does not take into account the formation of frost on the coil and the defrost cycles).	Pe : Effective absorbed power in heating mode	Wf : Water flow in m³ per hour	Dp : Water pressure drop in KPa
-------------------------------------------------------------------------------------------------------------------------------------------------------------------------	---------------------------------------------------------	------------------------------------------	-------------------------------------------

Compared with the basic configuration, this option features an additional refrigerant/water heat exchanger on the compressor discharge line, allowing recovery of 15% of the rejected heat. This heat exchanger is large enough to recover heat for the production of free hot water simultaneously with chilled water production. The heating capacity of the heat recovery circuit is approximately equal to the power input of the compressor.

Typical heat recovery applications can be facilities with high domestic hot water usage, such as health care, hotels, etc.

Notes:

This option is available on cooling only and heat-pump versions.

Heat recovery can only occur when the unit is running either in cooling or heating mode.

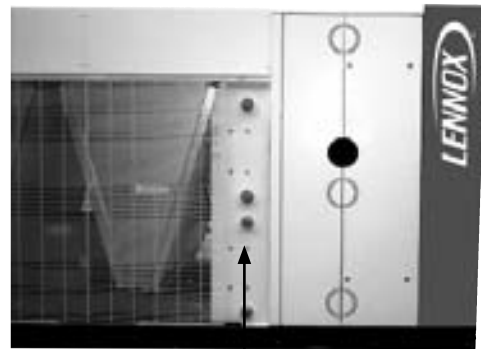
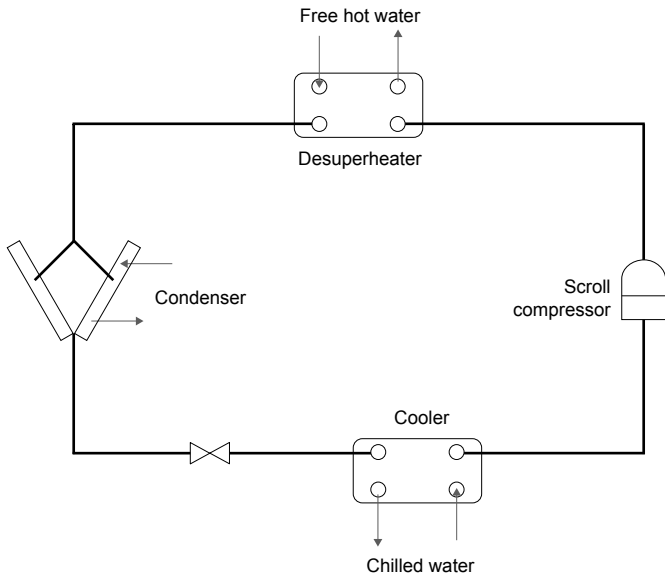

Partial heat recovery

	Water in/out: 50/55 °C			Water in/out: 55/60 °C			Water in/out: 50/60 °C		
	Recovery (kW)	Wf (m³/h)	Dp (kPa)	Recovery (kW)	Wf (m³/h)	Dp (kPa)	Recovery (kW)	Wf (m³/h)	Dp (kPa)
NAC/NAH 200	41	7,18	6,00	32	5,62	4	37	3,26	2
NAC/NAH 230	52	9,11	9,00	43	7,55	6	48	4,22	2
NAC/NAH 270	56	9,81	7,00	44	7,73	5	50	4,40	2
NAC/NAH 300	65	11,39	9,17	52	9,13	6	59	5,19	2
NAC 340	79	13,84	9,80	64	11,24	6	72	6,34	2
NAC 380	101	17,69	14,28	83	14,58	10	93	8,18	3
NAC 420	91	15,94	9,17	73	12,82	6	82	7,22	2
NAC 480	106	18,57	12,00	86	15,11	8	96	8,45	3
NAC 540	143	25,05	15,00	118	20,73	11	129	11,35	4
NAC 600	150	26,28	13,00	122	21,43	9	136	11,97	3
NAC 640	154	27,07	13,33	125	22,07	9	139	12,33	3

Wf :
Water flow in m³ per hour

Dp :
Water pressure drop in KPa

Compared with the basic configuration this option features one or two additional V free cooling coils at the back of the unit. The free cooling includes two motorised valves, allowing the chilled water to run through the free-cooling coils, which uses less power and utilises the lower ambient air to cool the water. The cooling capacity of one V free cooling coil at 0°C ambient is approximately 100 kW. NEOSYS™ free cooling system is using the same fans and speed inverters as for the standard unit in order to keep the same acoustic capabilities. The hydraulic module options are compatible with the Free Cooling option but glycol is of course required.

Typical free cooling applications can be facilities with cooling demand all along the year, such as offices with high internal loads like computer rooms, data centers, etc. In the North and North-East part of Europe, the ambient temperature is below 5°C between 20 and 45% of the year that makes this option very attractive.

Control principle

The control principle is the following: if ambient Temperature < return Temperature – 3°C, motorised valves open to by-pass return water flow through the Free Cooling coils. The Free Cooling fans are driven by the Climatic 50 via a specific PID algorithm. The Free cooling operation is considered as a cooling stage that has a priority on the compressor stages: only if the free cooling fan speed has reached the maximum fan speed then the compressors are allowed to run with their own PID.

Advantages of the NEOSYS™ free cooling system

- Simultaneous compressor cooling capability to reach building needs in any conditions (vs. DX free cooling that can not operate simultaneous compressor and free cooling).
- Design with additional V free cooling coils to eliminate unnecessary air pressure drop when running 100% in compressor cooling mode thus reducing all along the year energy fan consumption (vs. traditional free cooling system with free cooling coils located in series with the condensing coil.)
- Free cooling as soon as the air outside is cold enough (3°C below return water temperature).
- Reduce the running use of the compressors.
- Extend the life expectancy of the compressors.
- EER up to 63 (Water 15/10°C, Air -15°C).
- Reduce power costs.
- Payback could be as little as 12 months

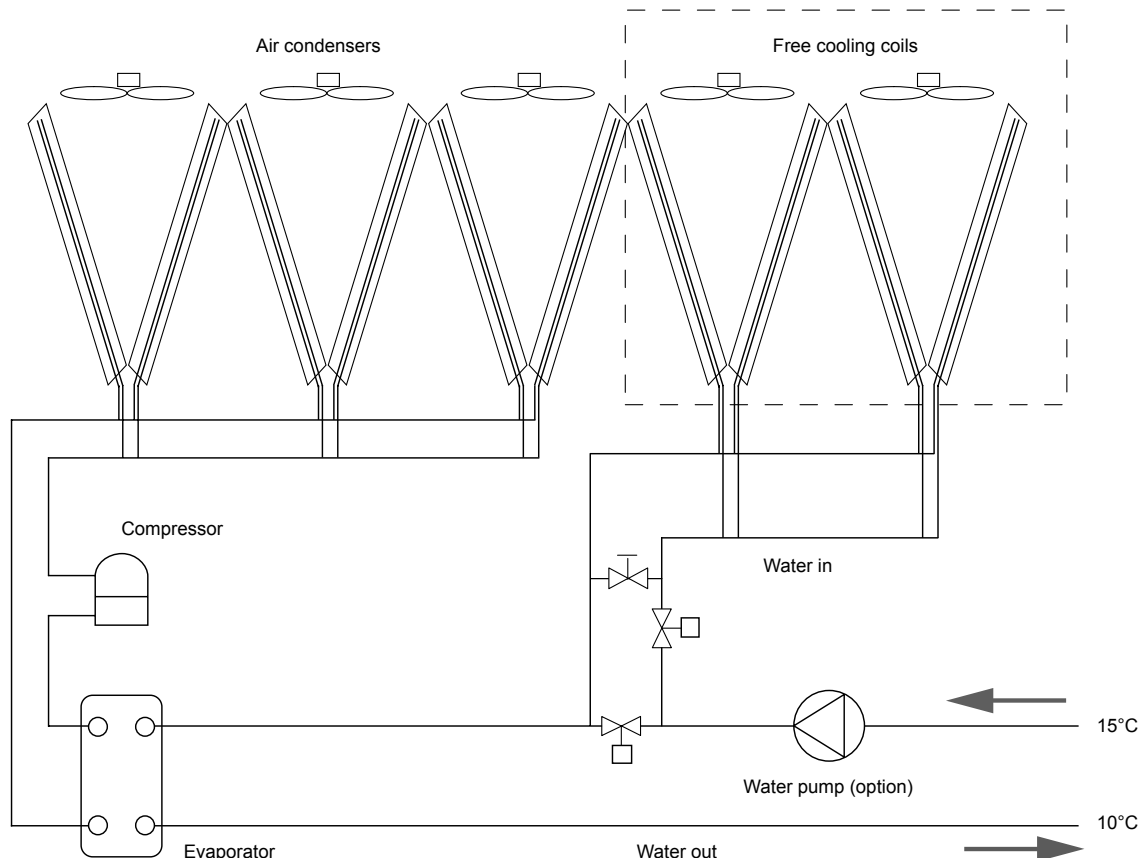

Example of free cooling:

Unit running 100% in free cooling mode:

Return water temperature: 12°C (30% glycol)

Number of "V"		1V for NAC 200 to 540					2V for NAC 200 to 540				
Air flow	m ³ /h	38000					76000				
Water flow	m ³ /h	36					72				
Ambient temperature	°C	-15	-10	-5	0	5	-15	-10	-5	0	5
Outlet temperature	°C	6,7	7,7	8,7	9,7	10,7	6,7	7,7	8,7	9,7	10,7
Free cooling capacity	kW	190	153	117	82	47	380	306	234	164	94
Free cooling absorbed power	kW	3,2	3,2	3,2	3,2	3,2	6,4	6,4	6,4	6,4	6,4
EER		59	48	37	26	15	59	48	37	26	15
Free cooling pressure drop to be added to evaporator pressure drop	kPa	57					62				

Return water temperature: 15°C (30% glycol)

Number of "V"		1V for NAC 200 to 540					2V for NAC 200 to 540				
Air flow	m ³ /h	38000					76000				
Water flow	m ³ /h	36					72				
Ambient temperature	°C	-15	-10	-5	0	5	-15	-10	-5	0	5
Outlet temperature	°C	9	10,1	11,1	12,1	13,1	9	10,1	11,1	12,1	13,1
Free cooling capacity	kW	214	177	140	104	69	428	354	280	208	138
Free cooling absorbed power	kW	3,2	3,2	3,2	3,2	3,2	6,4	6,4	6,4	6,4	6,4
EER		67	55	44	33	22	67	55	44	33	22
Free cooling pressure drop to be added to evaporator pressure drop	kPa	57					62				

**NAC 200 / 230 / 270
NAH 200 / 230**

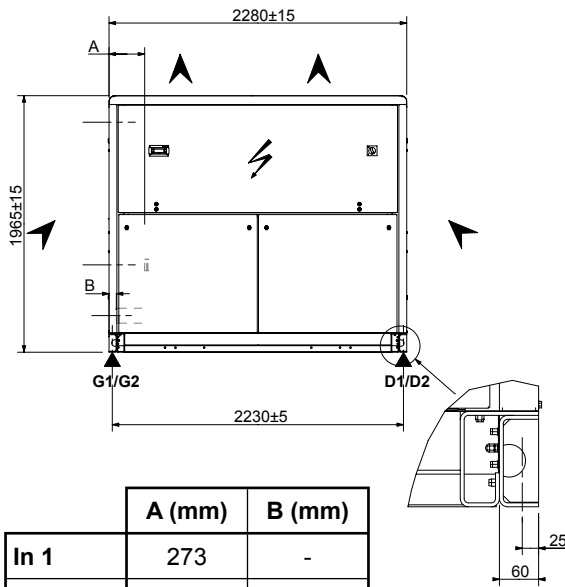

	A (mm)	B (mm)
In 1	273	-
In 2	62	-
Out	-	56

LEGEND :

- IN1 :** Water inlet - Unit without hydraulic module
- IN2 :** Water inlet - Unit with hydraulic module
- OUT :** Water outlet

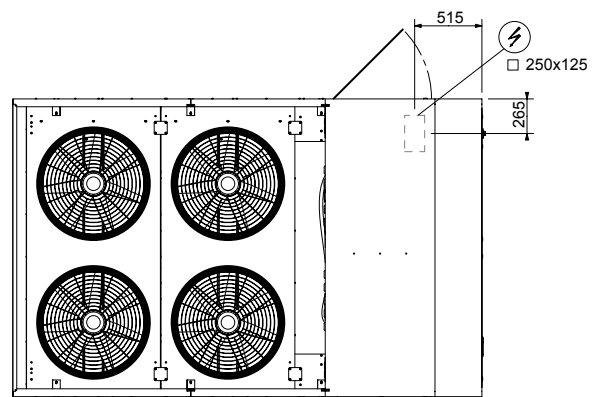
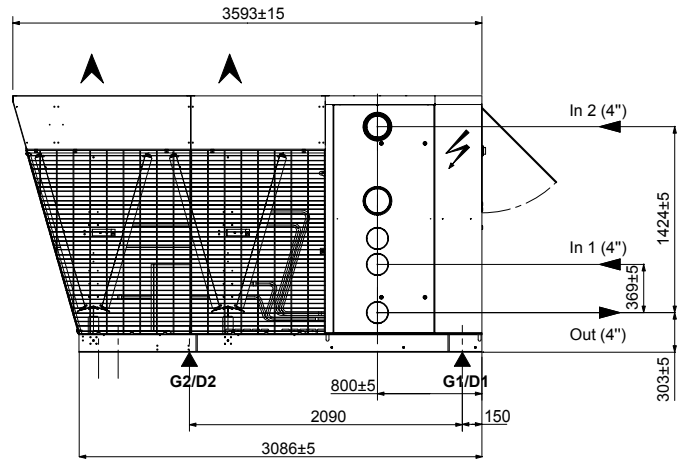

LOAD DITRIBUTION

(Kg - Operating weights with dual pump hydraulic module)

	G1	G2	D1	D2
NAC 200	561	561	561	561
NAC 230	586	586	586	586
NAC 270	650	650	650	650

	G1	G2	D1	D2
NAH 200	613	613	613	613
NAH 230	631	631	631	631

Lennox recommend load distribution as detailed above,

ANTI-VIBRATION MOUNTS (OPTION)

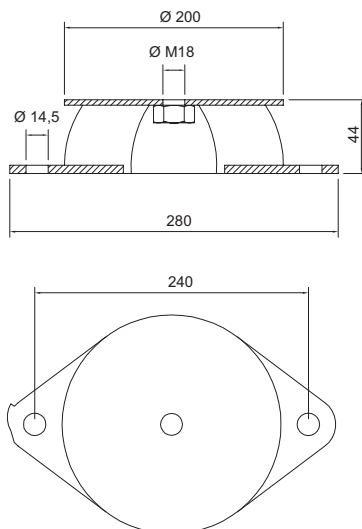

CLEARANCES

Overhead obstructions are not permitted

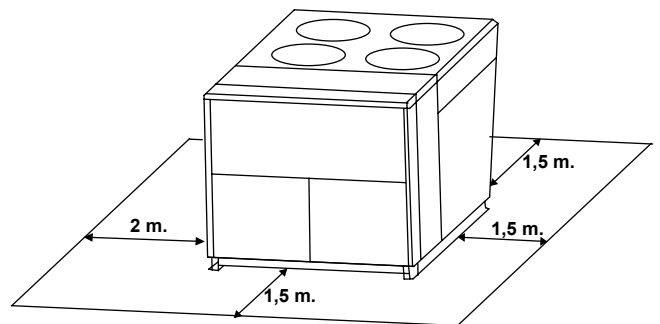

NAH 270

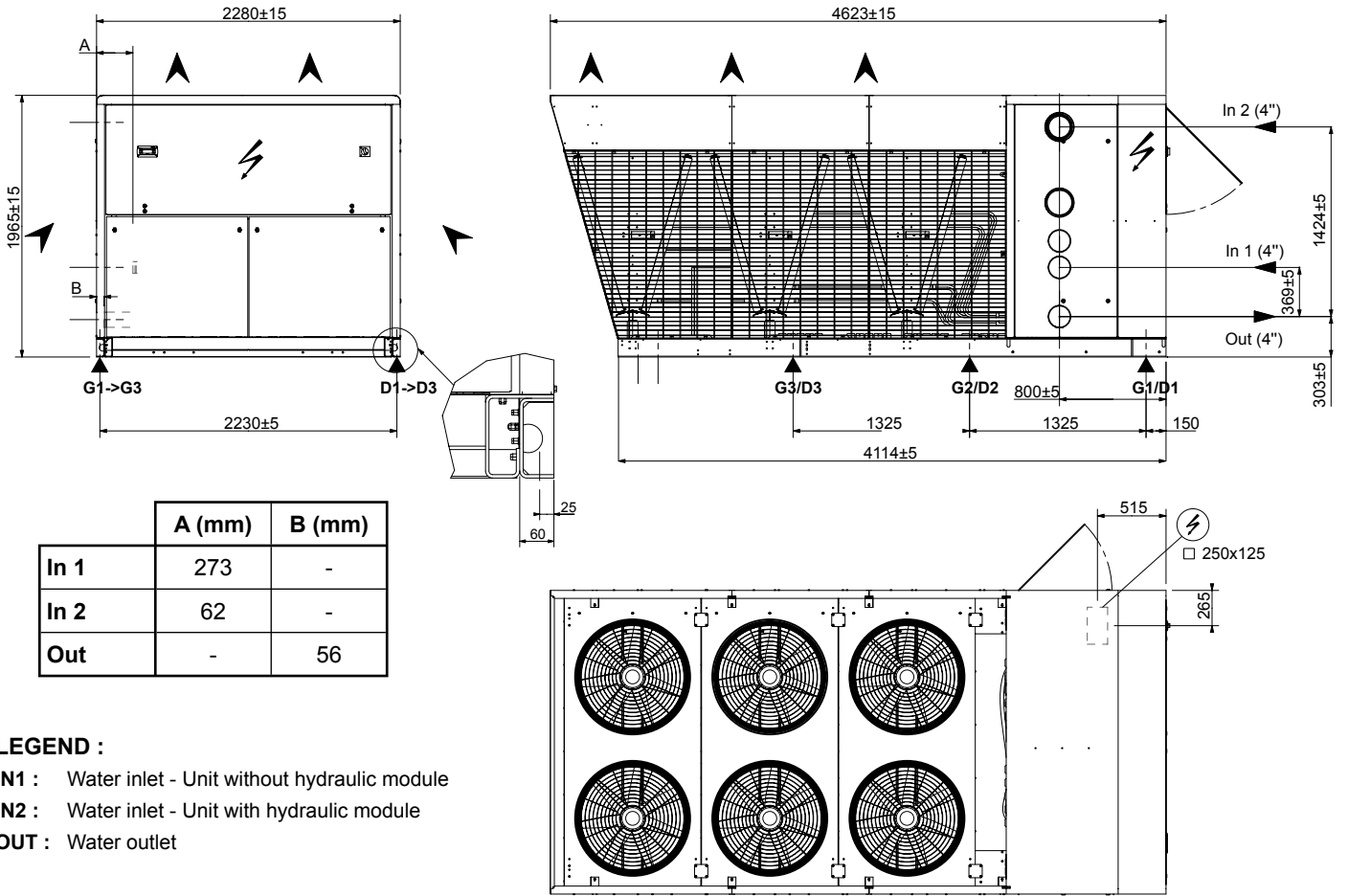

LOAD DITRIBUTION

(Kg - Operating weights with dual pump hydraulic module)

	G1	G2	G3	D1	D2	D3
NAH 270	543	543	543	543	543	543

ANTI-VIBRATION MOUNTS (OPTION)

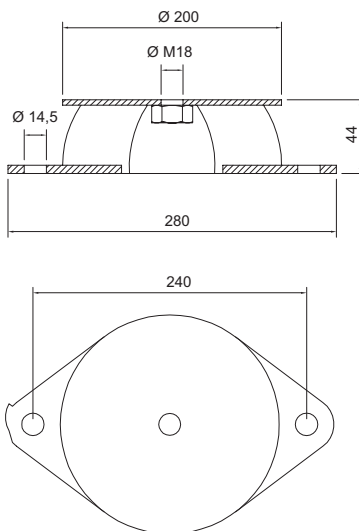

CLEARANCES

Overhead obstruction are not permitted

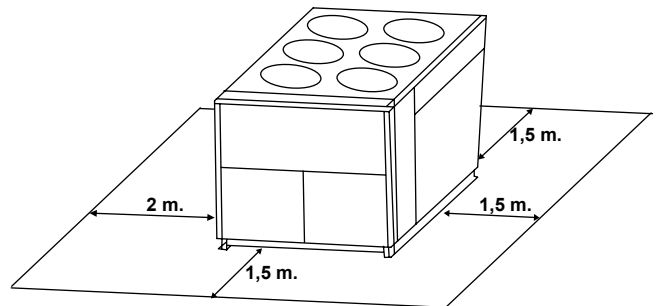

**NAC 300
NAH 300**

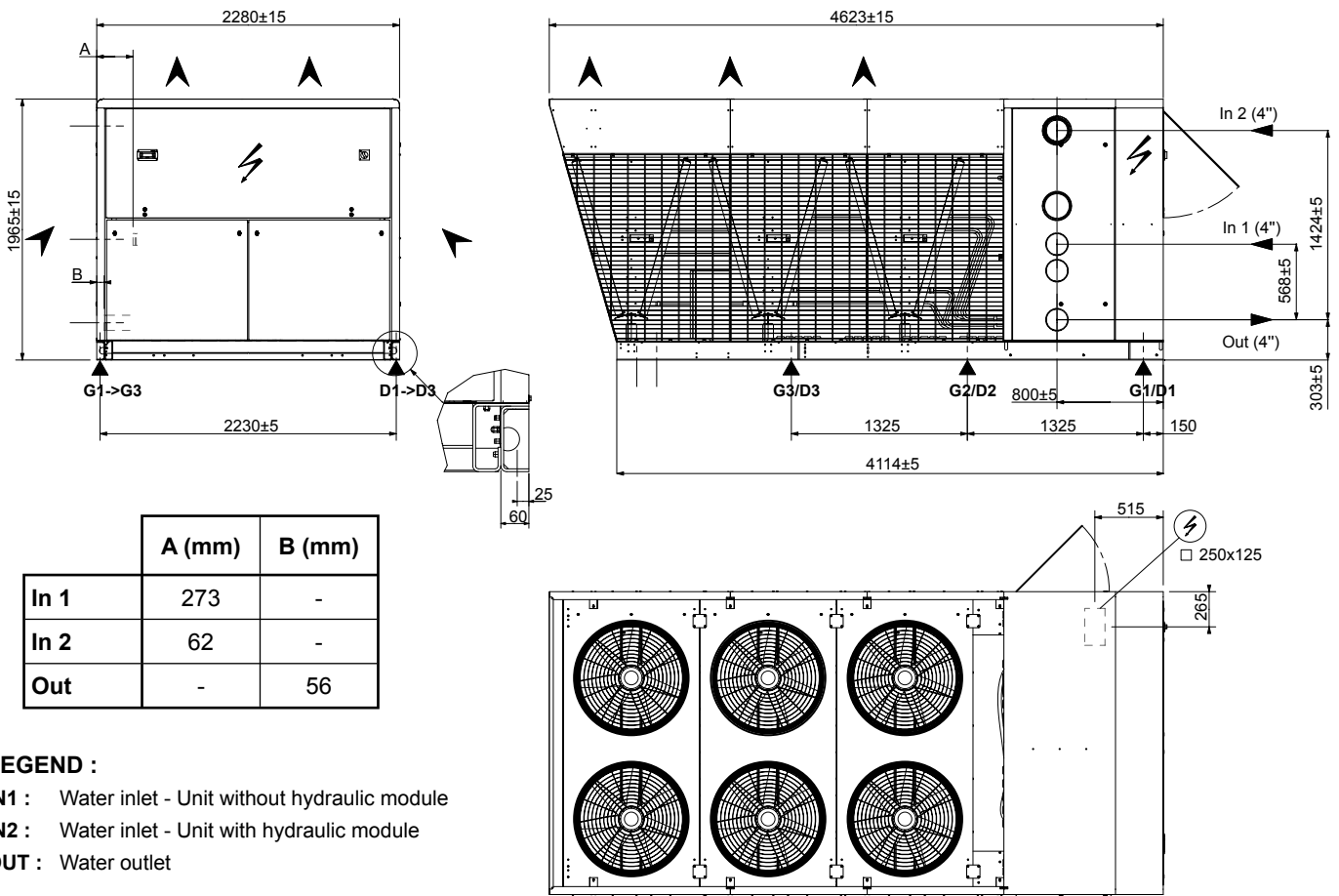

LEGEND :

- IN1 : Water inlet - Unit without hydraulic module
- IN2 : Water inlet - Unit with hydraulic module
- OUT : Water outlet

LOAD DITRIBUTION

(Kg - Operating weights with dual pump hydraulic module)

	G1	G2	G3	D1	D2	D3
NAC 300	501	501	501	501	501	501
NAH 300	548	548	548	548	548	548

ANTI-VIBRATION MOUNTS (OPTION)

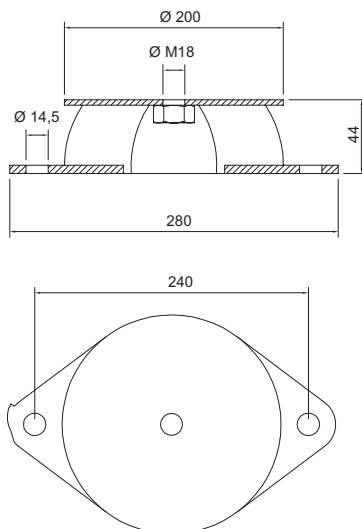

CLEARANCES

Overhead obstruction are not permitted

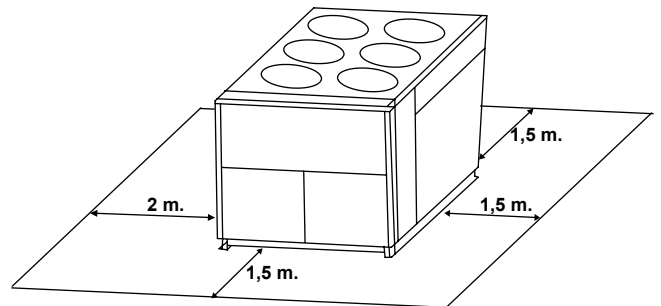

**NAC 340 / 380
NAH 340**

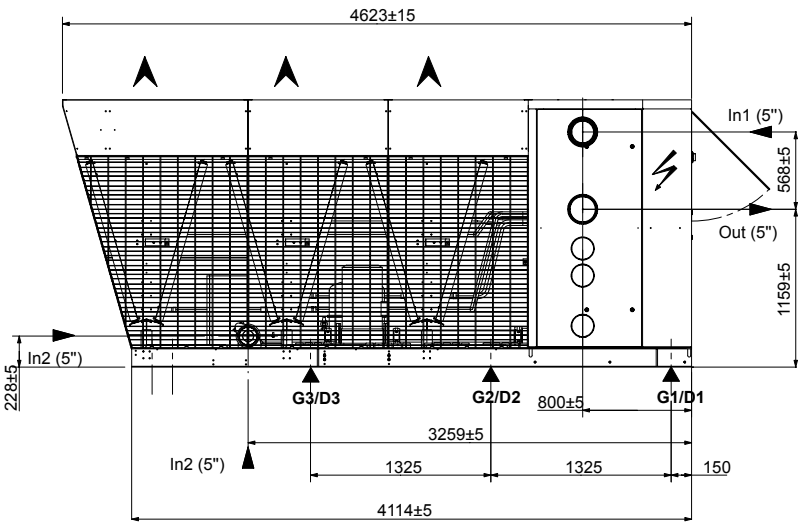
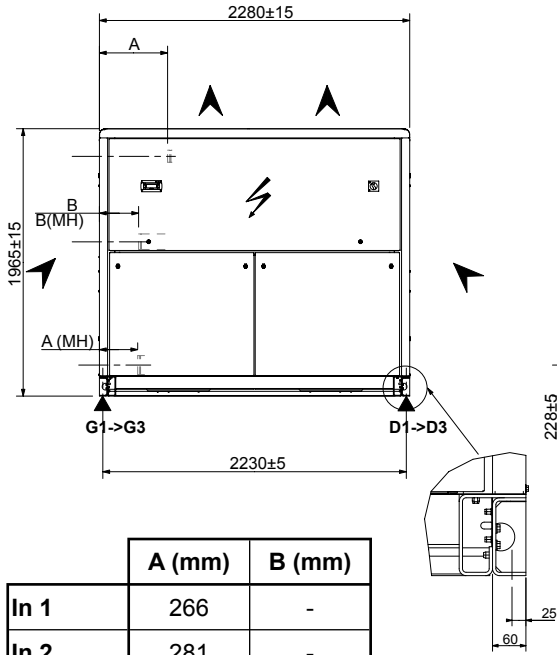

	A (mm)	B (mm)
In 1	266	-
In 2	281	-
Out	-	136
Out (MH)	-	122

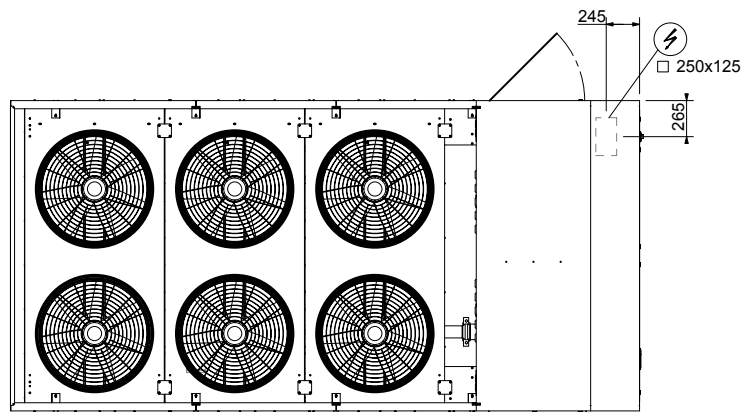

LEGEND :

- IN1 : Water inlet - Unit without hydraulic module
- IN2 : Water inlet - Unit with hydraulic module
- OUT : Water outlet
- OUT (MH) : Water outlet - Unit with hydraulic module

LOAD DISTRIBUTION

(Kg - Operating weights with dual pump hydraulic module)

	G1	G2	G3	D1	D2	D3
NAC 340	552	552	552	552	552	552
NAC 380	564	564	564	564	564	564

	G1	G2	G3	D1	D2	D3
NAH 340	902	902	-	902	902	-

ANTI-VIBRATION MOUNTS (OPTION)

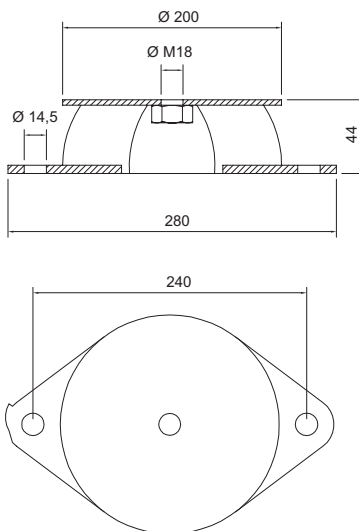

CLEARANCES

Overhead obstruction are not permitted

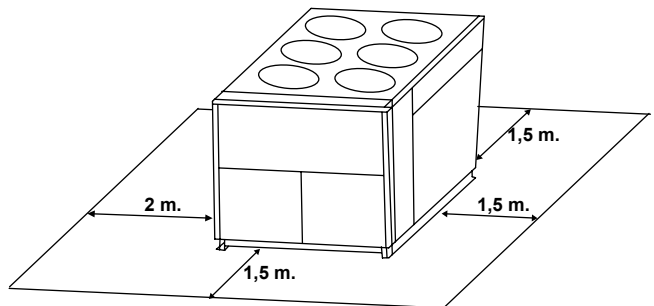

**NAC 420 / 480
NAH 380 / 420 / 480**

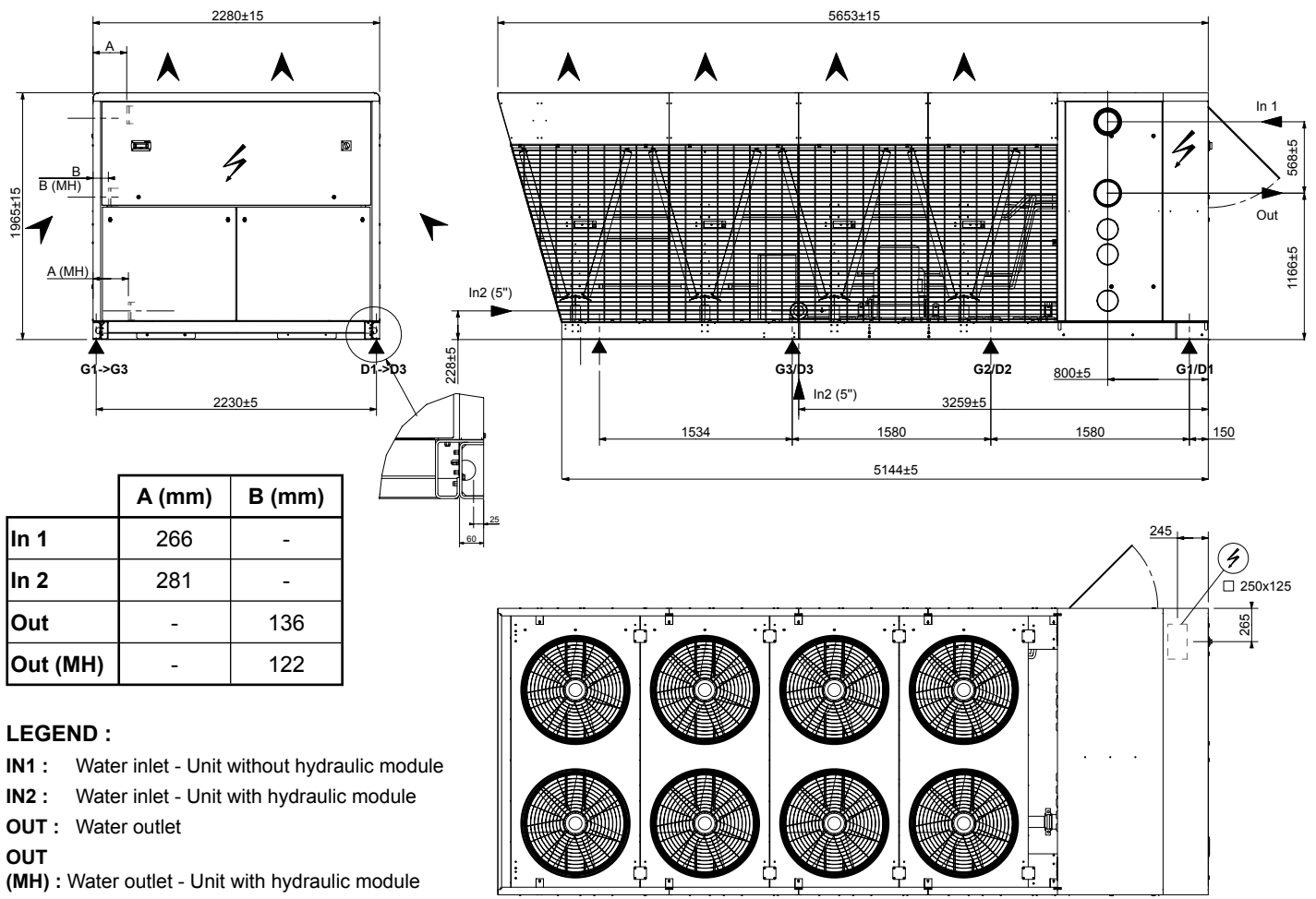

	A (mm)	B (mm)
In 1	266	-
In 2	281	-
Out	-	136
Out (MH)	-	122

LEGEND :
IN1 : Water inlet - Unit without hydraulic module
IN2 : Water inlet - Unit with hydraulic module
OUT : Water outlet
OUT (MH) : Water outlet - Unit with hydraulic module

LOAD DITRIBUTION

(Kg - Operating weights with dual pump hydraulic module)

	G1	G2	G3	D1	D2	D3
NAC 420	6506	650	650	650	650	650
NAC 480	669	669	669	669	669	669

	G1	G2	G3	D1	D2	D3
NAH 380	1033	1033	-	1033	1033	-
NAH 420	720	720	720	720	720	720
NAH 480	734	734	734	734	734	734

ANTI-VIBRATION MOUNTS (OPTION)

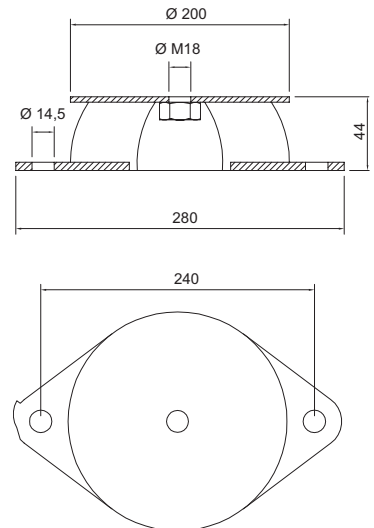

CLEARANCES

Overhead obstruction are not permitted

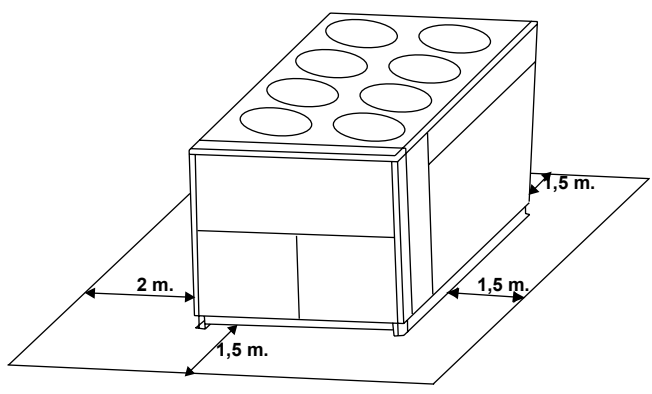

NAC 540

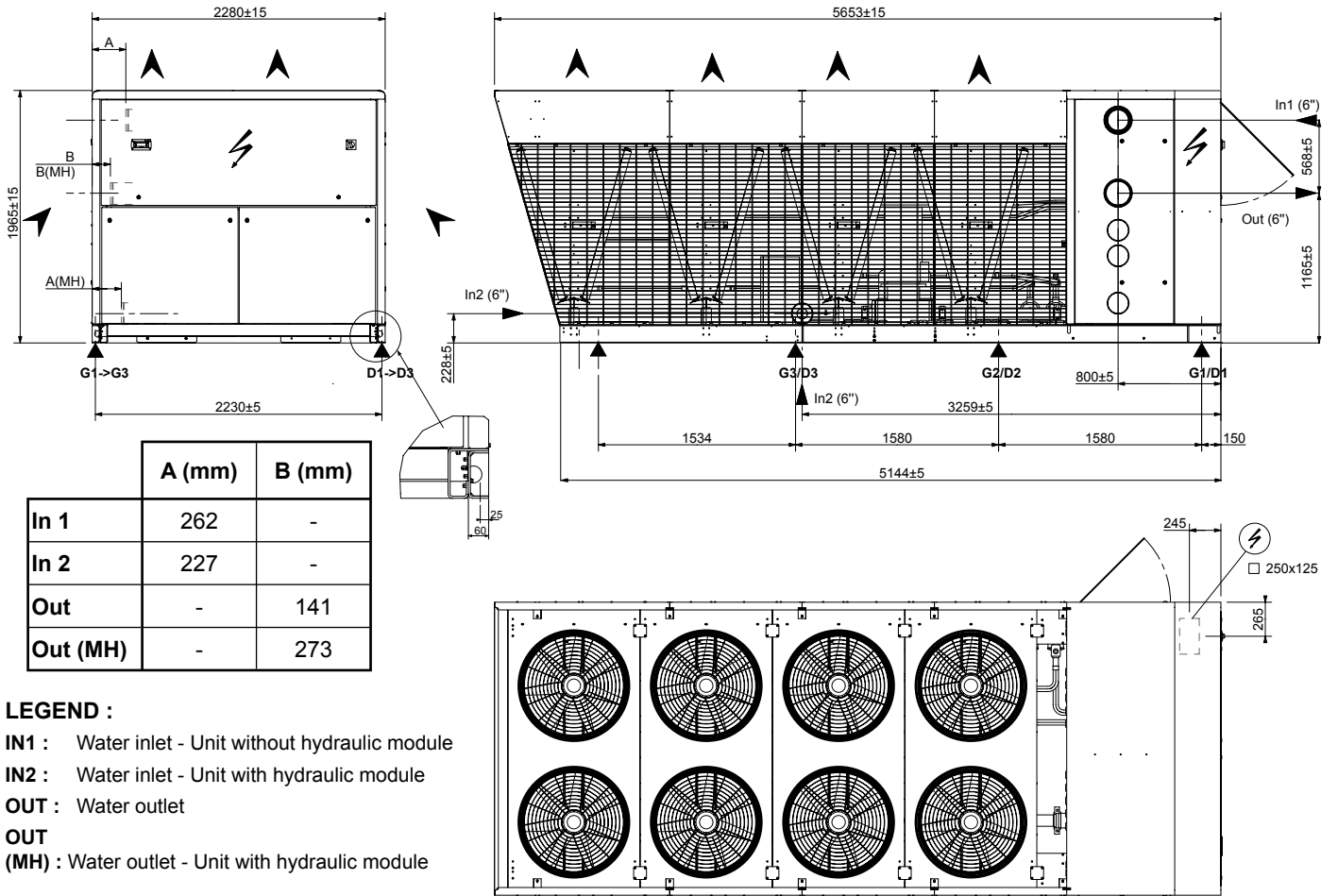

LOAD DISTRIBUTION

(Kg - Operating weights with dual pump hydraulic module)

	G1	G2	G3	D1	D2	D3
NAC 540	690	690	690	690	690	690

ANTI-VIBRATION MOUNTS (OPTION)

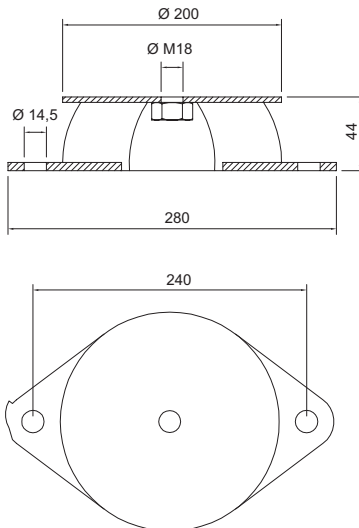

CLEARANCES

Overhead obstruction are not permitted

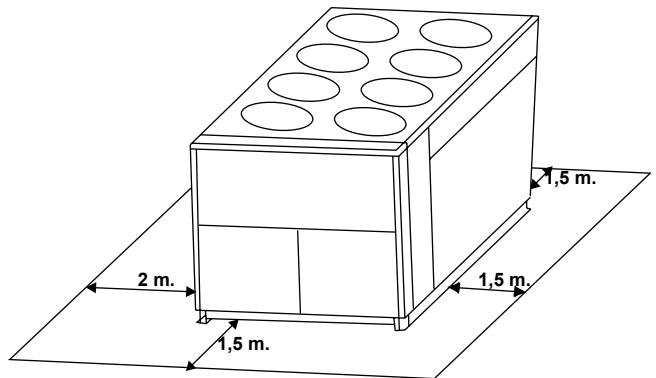

NAC 600 / 640

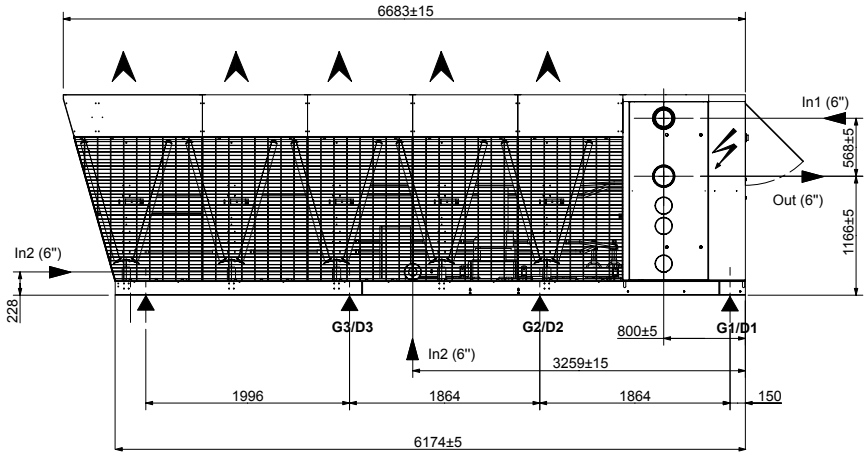
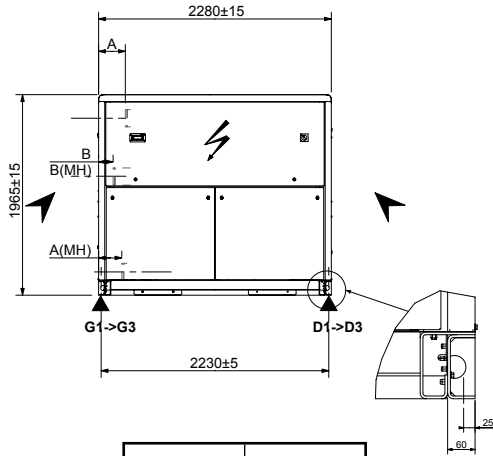

	A (mm)	B (mm)
In 1	262	-
In 2	227	-
Out	-	141
Out (MH)	-	273

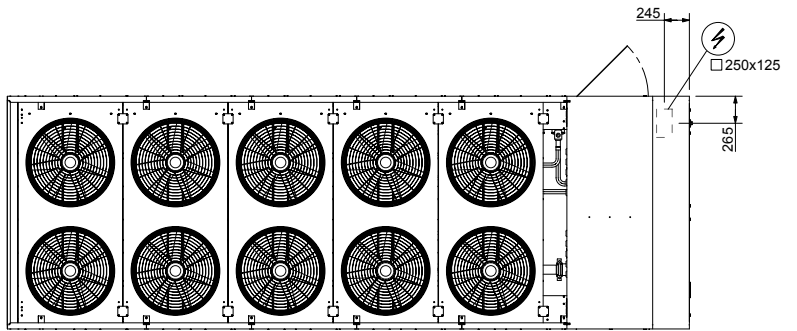

LEGEND :

- IN1 : Water inlet - Unit without hydraulic module
- IN2 : Water inlet - Unit with hydraulic module
- OUT : Water outlet
- OUT (MH) : Water outlet - Unit with hydraulic module

LOAD DISTRIBUTION

(Kg - Operating weights with dual pump hydraulic module)

	G1	G2	G3	D1	D2	D3
NAC 600	752	752	752	752	752	752
NAC 640	759	759	759	759	759	759

ANTI-VIBRATION MOUNTS (OPTION)

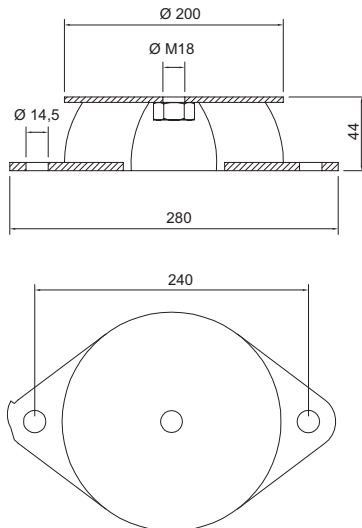

CLEARANCES

Overhead obstruction are not permitted

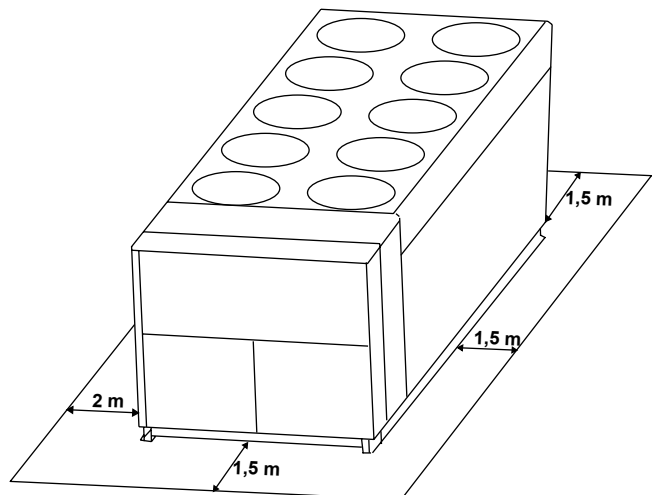

NAC 680 / 760

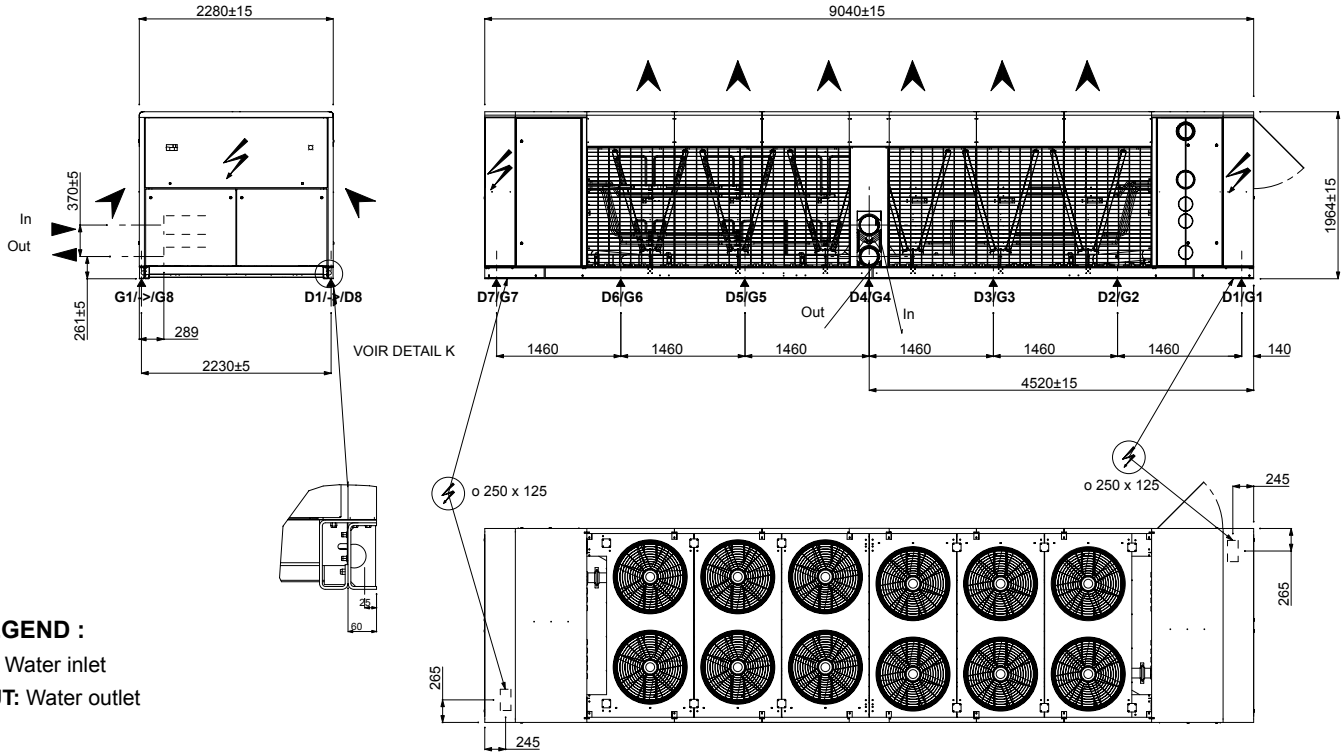

LEGEND :

IN: Water inlet

OUT: Water outlet

Note: In case of single main power connection (option), main power supply and disconnect switch are located at the right side of the unit.

LOAD DISTRIBUTION

(Kg - Operating weights with dual pump hydraulic module)

	G1	G2	G3	G4	G5	G6	G7	D1	D2	D3	D4	D5	D6	D7
NAC 680	480	480	480	480	480	480	480	480	480	480	480	480	480	480
NAC 760	490	490	490	490	490	490	490	490	490	490	490	490	490	490

ANTI-VIBRATION MOUNTS (OPTION)

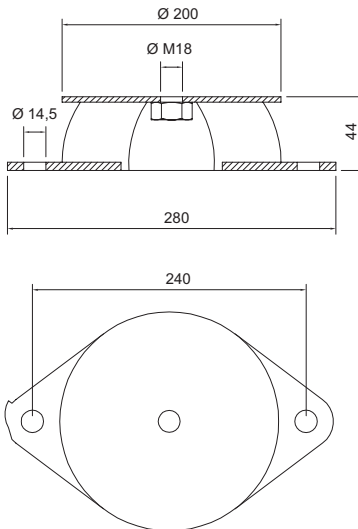

CLEARANCES

Overhead obstructions are not permitted

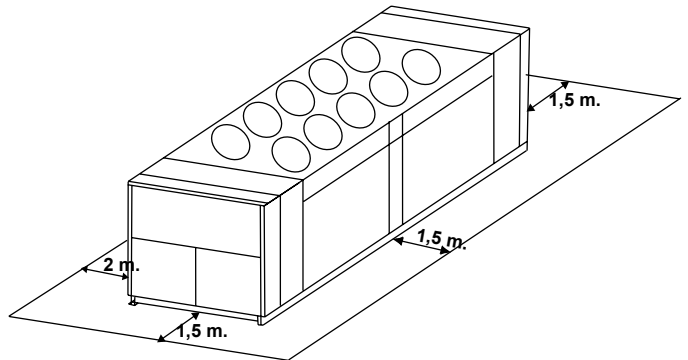

NAC 840 / 960 / 1080

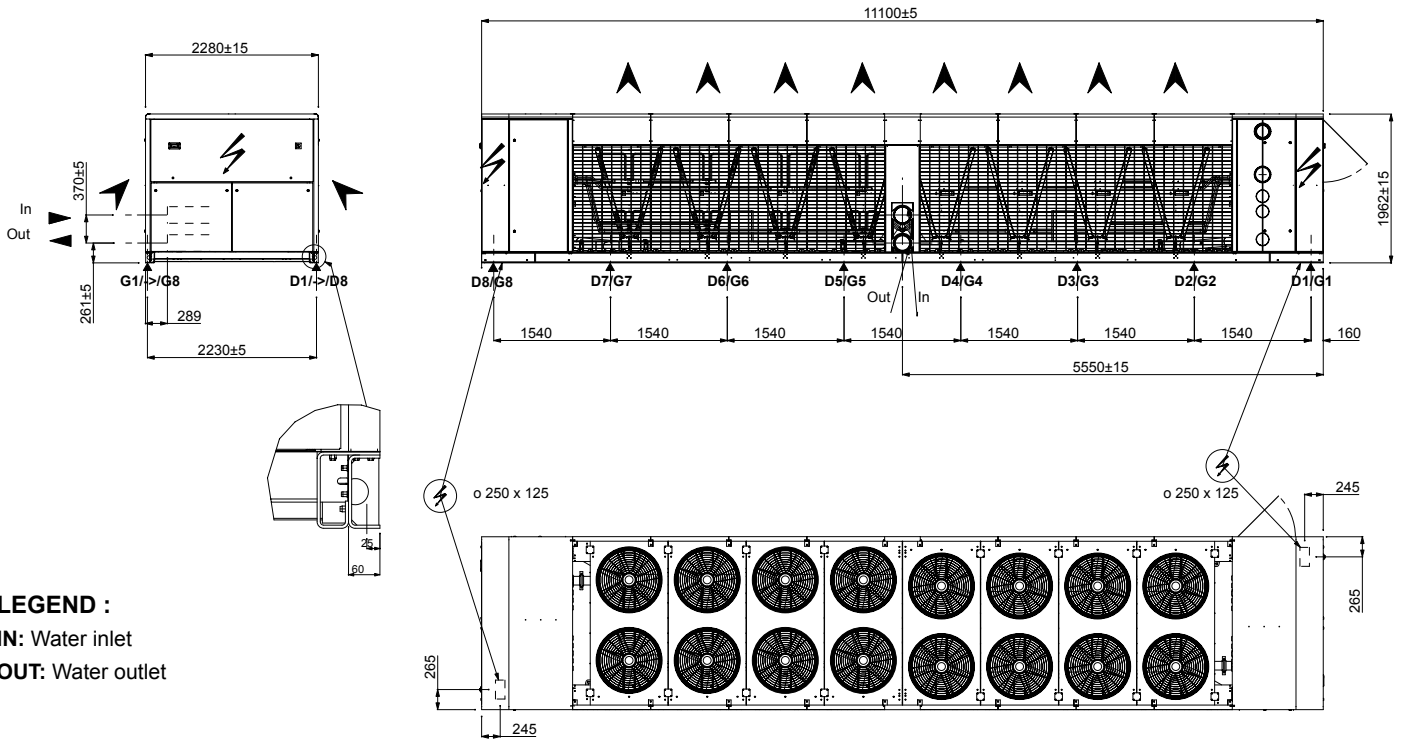

LEGEND :
IN: Water inlet
OUT: Water outlet

Note: In case of single main power connection (option), main power supply and disconnect switch are located at the right side of the unit.

LOAD DITRIBUTION

(Kg - Operating weights with dual pump hydraulic module)

	G1	G2	G3	G4	G5	G6	G7	G8	D1	D2	D3	D4	D5	D6	D7	D8
NAC 840	500	500	500	500	500	500	500	500	500	500	500	500	500	500	500	500
NAC 960	510	510	510	510	510	510	510	510	510	510	510	510	510	510	510	510
NAC 1080	510	510	510	510	510	510	510	510	510	510	510	510	510	510	510	510

ANTI-VIBRATION MOUNTS (OPTION)

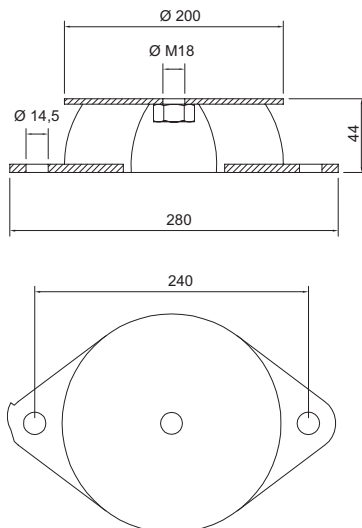

CLEARANCES

Overhead obstructions are not permitted

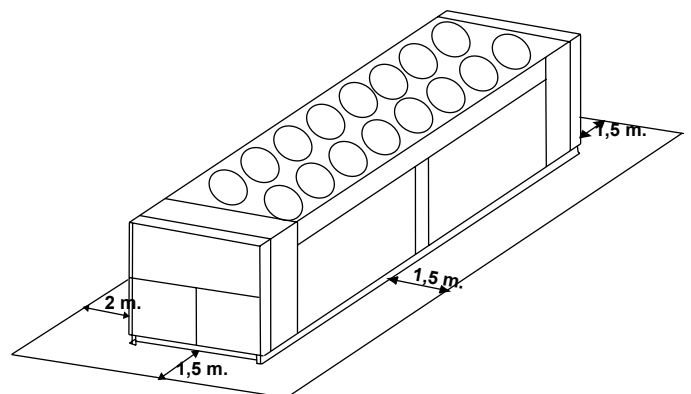

NAC

NAC		200	230	270	300	340	380	420	480
Without hydraulic module									
Operating weight	kg	1984	2011	2259	2648	2938	3010	3512	3621
Shipping weight	kg	1962	1989	2234	2615	2889	2962	3463	3564
With low pressure single pump									
Operating weight	kg	2191	2222	2476	2872	3177	3284	3786	3895
Shipping weight	kg	2157	2187	2439	2826	3110	3218	3719	3820
With low pressure double pump									
Operating weight	kg	2224	2258	2518	2920	3225	3367	3868	3977
Shipping weight	kg	2190	2223	2480	2874	3158	3300	3802	3903
With high pressure single pump									
Operating weight	kg	2201	2264	2518	2916	3221	3293	3797	3906
Shipping weight	kg	2167	2229	2480	2870	3154	3227	3731	3832
With high pressure double pump									
Operating weight	kg	2244	2343	2601	3008	3313	3385	3903	4012
Shipping weight	kg	2209	2309	2564	2963	3247	3319	3836	3937

NAC		540	600	640	680	760	840	960	1080
Without hydraulic module									
Operating weight	kg	3621	3992	4030	6720	6860	8000	8160	8160
Shipping weight	kg	3565	3927	3960	6445	6570	7700	7825	7815
With low pressure single pump									
Operating weight	kg	3957	4328	4366	NA	NA	NA	NA	NA
Shipping weight	kg	3883	4245	4278	NA	NA	NA	NA	NA
With low pressure double pump									
Operating weight	kg	4064	4435	4473	NA	NA	NA	NA	NA
Shipping weight	kg	3990	4352	4385	NA	NA	NA	NA	NA
With high pressure single pump									
Operating weight	kg	3995	4366	4404	NA	NA	NA	NA	NA
Shipping weight	kg	3921	4283	4316	NA	NA	NA	NA	NA
With high pressure double pump									
Operating weight	kg	4142	4513	4551	NA	NA	NA	NA	NA
Shipping weight	kg	4068	4430	4463	NA	NA	NA	NA	NA

NAH

NAH		200	230	270	300	340	380	420	480
Without hydraulic module									
Operating weight	kg	2193	2193	2917	2925	3233	3756	3927	4015
Shipping weight	kg	2171	2171	2892	2892	3184	3708	3878	3958
With single pump									
Operating weight	kg	2400	2404	3134	3149	3472	4030	4201	4289
Shipping weight	kg	2366	2369	3097	3104	3405	3964	4135	4215
With double pump									
Operating weight	kg	2433	2440	3176	3197	3520	4113	4283	4372
Shipping weight	kg	2399	2405	3139	3152	3454	4046	4217	4297
With high pressure single pump									
Operating weight	kg	2410	2446	3176	3193	3516	4039	4212	4300
Shipping weight	kg	2376	2412	3139	3148	3449	3973	4146	4226
With high pressure double pump									
Operating weight	kg	2453	2525	3260	3286	3608	4131	4318	4406
Shipping weight	kg	2418	2491	3222	3240	3542	4065	4252	4332

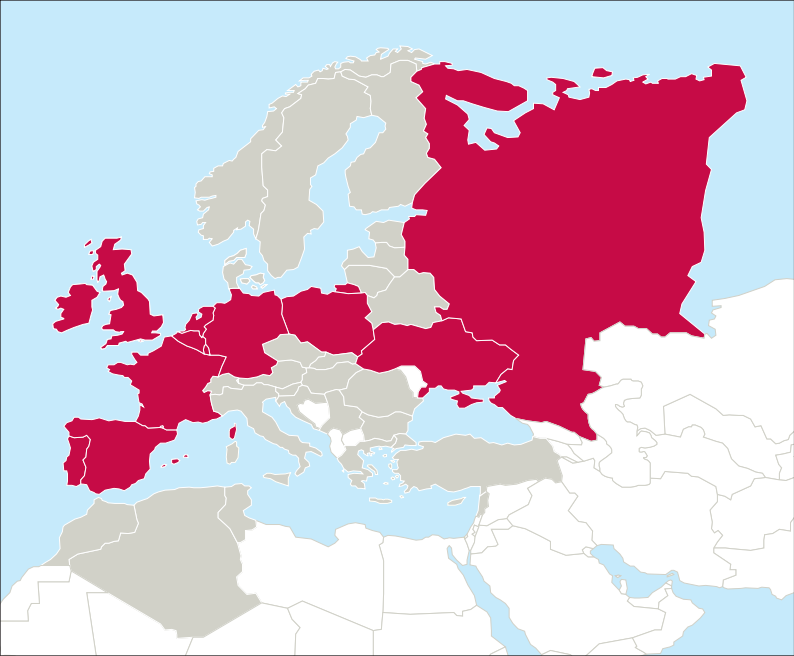

● **Direct Sales Offices:**

BELGIUM AND LUXEMBOURG

☎ + 32 3 633 3045

✉ info.be@lennox europe.com

FRANCE

☎ +33 1 64 76 23 23

✉ info.fr@lennox europe.com

GERMANY

☎ +49 (0) 6071 3915919

✉ info.de@lennox europe.com

NETHERLANDS

☎ + 31 332 471 800

✉ info.nl@lennox europe.com

POLAND

☎ +48 22 58 48 610

✉ info.pl@lennox europe.com

PORTUGAL

☎ +351 229 066 050

✉ info.pt@lennox europe.com

RUSSIA

☎ +7 495 626 56 53

✉ info.ru@lennox europe.com

SPAIN

☎ +34 902 533 920

✉ info.sp@lennox europe.com

UKRAINE

☎ +380 44 461 87 79

✉ info.ua@lennox europe.com

UNITED KINGDOM AND IRELAND

☎ +44 1604 669 100

✉ info.uk@lennox europe.com

● **Distributors and Agents**

Algeria, Austria, Belarus, Botswana, Bulgaria, Cyprus, Czech Republic, Denmark, Estonia, Finland, Georgia, Greece, Hungary, Israel, Italy, Kazakhstan, Latvia, Lebanon, Lithuania, Morocco, Near East, Norway, Romania, Serbia, Slovakia, Slovenia, Sweden, Switzerland, Tunisia, Turkey

LENNOX DISTRIBUTION

☎ +33.4.72.23.20.00

✉ info.dist@lennox europe.com



NEOSYS-AGU-0610-E

Due to Lennox's ongoing commitment to quality, the specifications, ratings and dimensions are subject to change without notice and without incurring liability.

Improper installation, adjustment, alteration, service or maintenance can cause property damage or personal injury.

Installation and service must be performed by a qualified installer and servicing agency