

APPLICATION GUIDE



LENNOX participates in the ECP programme for LCP-HP. Check ongoing validity of certificate : www.eurovent-certification.com

NEOSYS NAC - NAH

AIR COOLED CHILLER & HEAT PUMP

200 - 1000 kW

NEOSYS-AGU-1801-E



NEOSYS

APPLICATION GUIDE

Ref : NEOSYS-AGU-1801-E

1. GENERAL

Model number description	2
Key customer benefits	3
Features and benefits	4
Technical description	6
Options and accessories	8

2. GENERAL DATA

General data	10
Pressure drops	17
Hydraulic data	19
- eDrive	23
- Partial heat recovery	27
- Total heat recovery	28
- Free-cooling	30
Acoustic data	32
Operating limits	33

4. ELECTRICAL DATA

Electrical tables	34
-------------------	----

5. PERFORMANCES

NAC	37
NAH	50

6. DIMENSIONAL DATA

Dimensional data	52
Weight data	62



Our company's products comply with European standards.

All the technical and technological information contained in this manual, including any drawing and technical descriptions provided by us, remain the property of Lennox and must not be utilised (except in operation of this product), reproduced, issued to or made available to third parties without the prior written agreement of Lennox.

EXAMPLE : NAC 200D N M5 M

N	NEOSYS
A	Air cooled
C	C = Cooling mode H = Heat pump mode
200	Cooling capacity in kW
D	Number of circuits : S = 1 circuit D = 2 circuits T = 3 circuits F = 4 circuits
N	Non ducted
M	R410 A refrigerant
5	Revision number
M	400V/3/50 Hz

Air-cooled Liquid Chiller for outdoor installation (NAC)**Air-to-water Heat Pump for outdoor installation (NAH)****Nominal cooling capacity :**

200 ► 1000 kW (NAC)

200 ► 450 kW (NAH)

Nominal heating capacity :

200 ► 500 kW (NAH)

Sustainable Performance

- **Extended qualification tests** (vibration tests, run tests, field tests) to ensure superior reliability.
- **High efficiency aluminium micro channel heat exchanger (MCHX)** with improved corrosion resistance for moderate marine or urban applications (Cooling only version). **3-year warranty***.
- **Specific MCHX coil design** with high mechanical fin resistance that offers easy cleaning with high pressure air or water washers for extended life cycle.
- **V-coil design**, compressor and hydraulic enclosure to protect the unit against climatic conditions (e.g. sun rays, UV light, hail).
- **Exclusive Compliant Scroll® compressor design** with both axial and radial compliance to increase compressor operation tolerance of liquid refrigerant or debris, substantially improving durability and reliability. **3-year warranty***.
- **Exclusive fan design with SKF hybrid Ceramic bearings** to double (treble in some cases) the service life of the motors and to reduce noise level. With these sealed hybrid ceramic bearings, our customer can expect little or no maintenance of the motor throughout its life. **3-year warranty***.

Quiet performance

- **Unique design** with compressor, pump(s) and fan acoustic enclosure to reduce radiated noise emissions.
- **Inverter fans** using external rotor technology associated with high performance aluminium fan blades of the latest generation (Owlet™ design).
- **Elimination of intrusive fan start/stop noise** that is irritating to the human ear.
- **Active Acoustic Attenuation System™** to meet changing building load requirements while automatically adjusting the air flow to meet night and day sound level constraints (Time schedule with 4 time zones per day).

Quick performance and service

- **Complete hydraulic module** with single or twin, low or high pressure pump (options) that includes all necessary equipment for quick connection: pump(s), regulating valve, expansion tank vessel with pressure gauge, pressure tapping points, water filter, air vent, pressure relief valve and Victaulic connections.
- 400V, 50 Hz, 3 phase power supply (without neutral) with a single point of power connection. Main on/off switch included in as standard.
- **Air spring powered Butterfly electrical panel** with jacks top opening providing protection to service engineers against rain or snow during commissioning and maintenance operations.

**Energy performance**

- **High Energy Performance** (ESEER above 4; EER up to 2.9 ; COP up to 3,2) for improved energy consumption all around the year.
- **Aluminium micro channel heat exchanger** that offers +10% outstanding system efficiency (cooling only version).
- **R410A refrigerant** for optimized system performance.
- **Energy savings** due to lower system minimum water content reducing the time to reach setpoint. This can also eliminate the need for a buffer tank.

Architectural integration

- **State of the art design** with hidden compressors, fans and pump for perfect architectural integration.
- **Flat top, aesthetic grilles, very low unit height** (< 2 m) for discrete installation on a roof reducing the requirement of costly cladding solutions around the unit.

* This warranty covers parts only. The above warranty is liable if the start-up and periodic maintenance agreement is contracted by a LENNOX company or any company accredited by LENNOX. Refer to LENNOX 3 year warranty conditions.

Flat top and low profile for best architectural integration



The NEOSYS design is minded to be perfectly integrated into urban or residential environments. The state of the art design of NEOSYS includes a painted casing, a flat top that hides the fans and aesthetic protection grilles.

The very low unit height less than two meters makes easier for architects and design engineers to integrate the unit on a roof. Many interviewed customers confirm that the state of the art design of NEOSYS will replace any requirement of costly cladding solutions around the unit.

Smarts acoustics with inverter fans

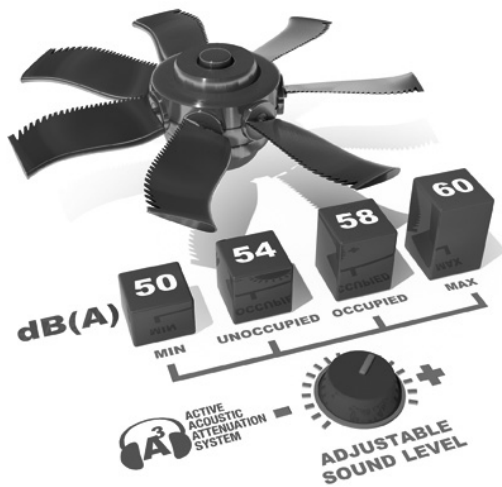

No more need to make a choice between a high efficiency version, a low noise or an ultra low noise version. NEOSYS can adapt all situations with only one version. NEOSYS is fitted in standard with the Active Acoustic Attenuation System™ that is using an electronic control associated with inverter fans. NEOSYS can change automatically the speed of all the fans – from 0% to 100% of the nominal air flow – to meet the building load requirements while respecting maximum authorised noise level in the time zone. NEOSYS is surely achieving the best acoustic signature of the market thanks to the latest generation of Owlet™ high performance aluminium fan blades and noiseless ceramic bearings.

ACTIVE ACOUSTIC ATTENUATION SYSTEM™

SELECT YOU MODE PER TIME ZONE

Performance Mode

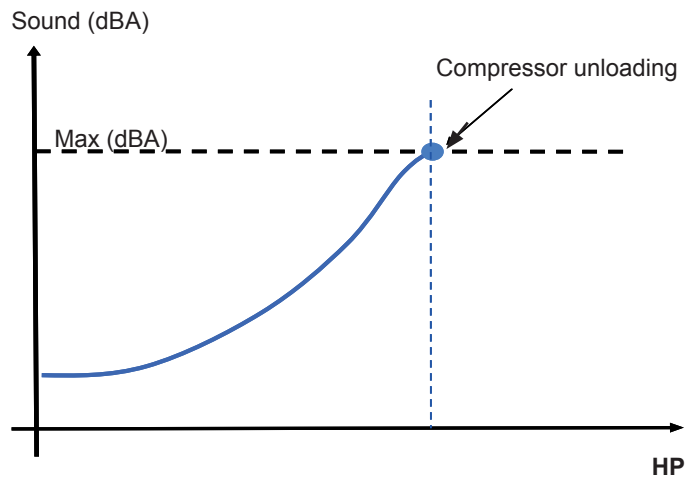

Auto Quiet Mode

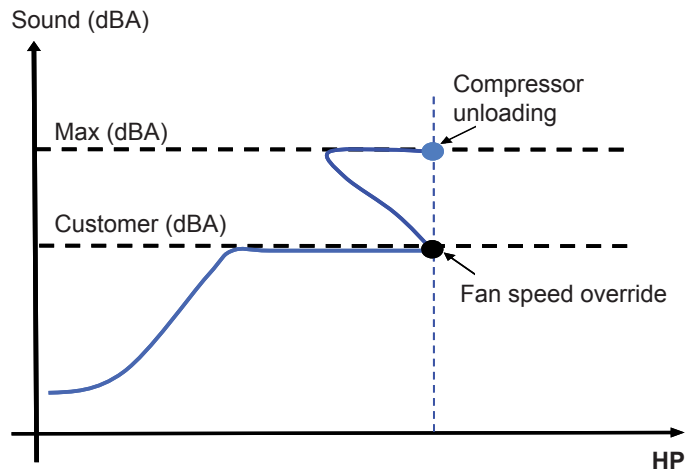

Quiet Mode

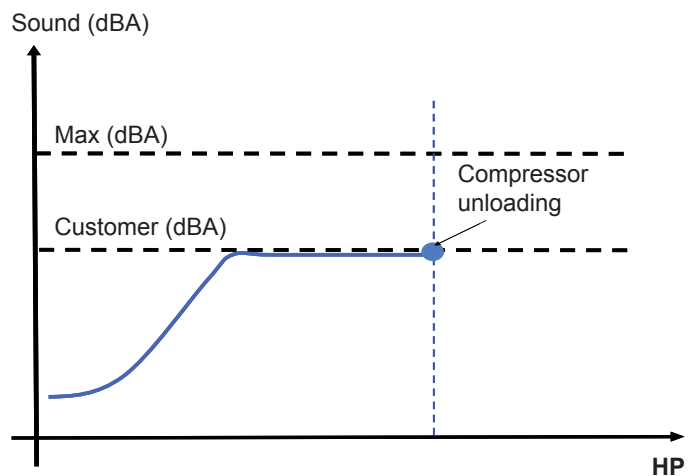

A high energy performance

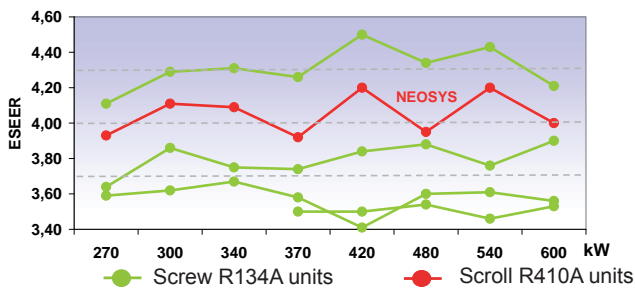

Floating high pressure

LENNOX optimizes the performance of the NEOSYS chillers with electronic expansion valve (as an option) and variable speed ventilation (as standard) to achieve maximum energy savings.

We define a condensation temperature depending on the outside air temperature at an optimum value to obtain the lowest power inputs of couples, compressors and condenser fan motors.

By using R410A refrigerant associated with high efficiency micro channel coils and variable speed fans NEOSYS is contributing to a very low energy consumption all year around with an average energy efficiency ratio (ESEER)* in cooling mode above 4.0. NEOSYS Heat-pumps are also achieving very high performances in cooling and heating mode (COP* up to 3.2). Furthermore NEOSYS advanced control allows energy savings all year around by using smart control functions:

- Low water system quantity to reduce the time to reach the set-point.
- Dynamic defrost (patented) to limit the number of defrost cycles.
- Set-point reset based on outside air temperature to relax the chilled water set-point.

*ESEER : European Seasonal Energy Efficiency Ratio in cooling mode.
COP : Coefficient of Performance in heating mode.

R410A Micro channel heat exchanger

With the use of fully aluminium coils already used in the automotive industry, NEOSYS offers many customer benefits:

- Up to 40% less refrigerant charge that contributes to reduce the total amount of refrigerant used in the system.
- A more efficient system (EER + 10%).
- An air heat exchanger with significantly improved corrosion resistance results (x 2) from the same aluminium alloy (no galvanic action) vs. the traditional copper tube/aluminium fin coils. By using this type of coil, units can be used in light corrosive or seacoast environments without any need for additional, and expensive, pre-treated fins or coil coating.
- High mechanical resistance eases the cleaning with high pressure air or water washers without any risk of damaging the fins.

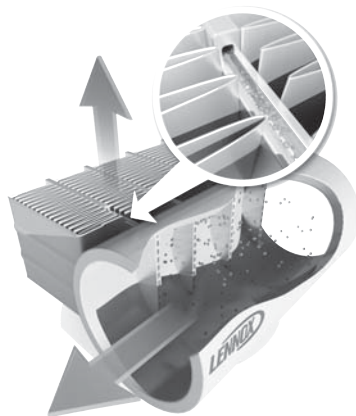

Available in cooling only version, this technology will surely be enlarged shortly to reversible applications.

GENERAL CHARACTERISTICS OF THE UNIT

The NEOSYS unit is designed to be integrated into urban or residential environments.

As main characteristics the NEOSYS unit offers **state of the art design** to match architectural constraints and **adjustable sound level performances** during day and night to satisfy local environmental constraints.

CASING/CHASSIS

- Casing made of galvanised steel sheet metal painted with a white powdered polyester paint and a red stripe.
- Fully grey colour painted chassis protecting against corrosion.
- **State of the art design** with hidden compressors, fans and pump for perfect architectural integration.
- Flat top, aesthetic grilles, **very low unit height (2 meters)** for discrete installation on a roof reducing the requirement of costly cladding solutions around the unit
- **Aesthetic side anti-intrusion grilles** as standard to protect the unit during transportation and against human aggressions.

COMPRESSOR

- Exclusive Compliant Scroll® design with both axial and radial compliance to increase compressor operation tolerance to liquid refrigerant, substantially improving durability and reliability. **3-year warranty***.
- Motor cooled by suction gas.
- Electronic control of the compressor discharge temperature.
- Motor protection device against high temperature or over current situations.
- Discharge non-return valve.
- Low noise scroll compressors mounted in a sound-proofed technical cabinet to reduce noise emissions.
- Compressors assembly installed on an independent chassis supported by anti-vibration mountings.

WATER HEAT EXCHANGER

- True dual circuit plate heat exchanger
 - Copper brazed Stainless steel plate heat exchanger.
 - 13 mm thermal insulation foam.
 - Water heat exchanger located in a technical cabinet protecting the insulation against climatic conditions (UV light, rain).
- 3-year warranty***

AIR HEAT EXCHANGER

- High efficiency aluminium Micro Channel heat exchangers (MCHX) with improved corrosion resistance in moderate marine or urban environment (cooling only version). **3-year warranty***.
- Standard copper tubes/aluminium fins heat exchanger (heat pump version).
- V-coil design to protect the unit against climatic conditions (e.g. hail).

FANS

- Inverter fans (0 to 900 rpm operating range).
- **Active Acoustic Attenuation System™** to meet changing building load requirements while automatically adjusting the air flow to respect night and day sound level constraints (adjustable setting over time schedule with 4 time zones per day).
- Elimination of intrusive start/stop noise that is irritating to the human ear.
- Fan-motor assembly using external rotor technology associated with owl high performance aluminium fan blades of the latest generation.
- IP 54 electrical motor, class F protected against high temperature with an internal sensor.
- Exclusive fan design with hybrid Ceramic bearings to extend the service life of motors and to reduce noise level. With these sealed hybrid ceramic bearings, our customer can expect little or no maintenance of the motor throughout its life. **3-year warranty***.
- Extremely rigid fan assembly via the integration of the fans mounted within a pre-formed bell mouth roof panel, thus improving rigidity while reducing vibrations.
- Rounded top acoterion panels to hide the fans and reduce noise emissions for quieter operation.

REFRIGERANT CIRCUIT

NEOSYS uses R410A refrigerant in 2 independent circuits (minimum). Each circuit includes:

- **A refrigerant charge reduced by 30%** due to the use of R410A combined with micro channel heat exchanger (NAC/Cooling only version).
- Suction piping with thermal insulation.
- Filter drier with removable cartridge filter.
- Thermostatic or electronic expansion valve (Electronic device only when "winter operation" option selected).
- Temperature sensors and pressure transducers.
- Four-way valve and liquid receiver (heat pump units only).
- Leak-tight refrigerant circuit with brazing carried out under nitrogen by certified engineers.
- Each refrigerant circuit is pressure and leak tested with a Hydrogen/Nitrogen mixture, and vacuumed before being charged with refrigerant. All units are then subjected to a complete functional and operational run test to guarantee perfect sealing before leaving the factory.

* Warranty under conditions - See page 3

ELECTRICAL BOX

- Unit electrical cabinet, components and wiring in compliance with EN 60204-1 electrical directive.
- 400V, 50 Hz, 3 phase power supply (without neutral) with a single point of power connection (except sizes 680 to 1080).
- Bottom entry (through the base) for electrical power.
- IP54 protection class.
- **Air spring powered Butterfly electrical panel** with top opening providing protection to the service engineers against rain or snow during commissioning and maintenance operations.
- Recognized brand electrical components (Schneider) for ease of maintenance.
- Main on/off switch mounted on the front panel.
- DC60 advanced user interface mounted on the front panel.
- Main disconnect switch with high trip capacity allowing optimized sizing of the customer power supply.
- 400/24 V transformer to supply the control circuit.
- Numbered electrical wires to facilitate maintenance and diagnostic.
- Variable Frequency Drives (VFD) to control the fan speed.

CONTROL

CLIMATIC microprocessor based control is providing the following functions:

- 4 scheduling time zones per day over 7 days to allow energy consumption and sound level management according to the building use and environmental constraints.
- PI control of the water temperature with operating time equalisation of the compressors.
- Water set-point offset based on outdoor air temperature.
- **Active variable speed control of all fans** to optimize the unit condensing pressure and energy performances at full- and part-load while meeting authorized maximum noise level in the time zone (Active Acoustic Attenuation System™ control patented).
- Intelligent advanced control algorithm to protect the compressors against excessive short-cycling and to allow **operation of the unit without buffer tank** in most comfort air conditioning applications (e.g. unit with fan-coils). Refer to minimum installation water loop volume recommendations.
- **Dynamic defrost** to limit the number and the duration of the defrost cycles in winter for high performance of the unit (Dynamic Defrost patented).
- Automatic compressor unloading in case of excessive condensing pressure allowing the operation of the machine at high outdoor air temperature (operation extended up to 46°C ambient).
- Water pump control with operating time equalization and automatic change-over in case of a pump fault (Twin pump only).
- Master/slave or cascade control of two chillers operating in parallel with operating time equalization and automatic change-over in case of a unit fault.

CLIMATIC is pre-factory configured with default settings allowing a fast commissioning on site. The DC60 advanced user interface with graphical display is easy to use, intuitive. Main customer parameters can be read or modified without main power shut-off (Entering/leaving water temperatures, outdoor air temperature, alarm history, scheduling of the different time zone, water and noise level set-points, high and low pressure reading).

The DS60 service display (optional) is a "plug and play" controller that allows service people to read and modify all unit parameters (Unit settings, operating time and number of compressor starts, low and high pressure reading, read the history of last 32 faults...).

COMMUNICATION

The control board is equipped with a RS485 serial communication port to allow remote management through communication bus. According to the wished communication protocol, our control board can be fitted with **ModBUS®**, **BacNET®** (**RS485 or TCP/IP**) or **LonWorks® communication interface** (options).

The main control board has free dry contacts that allow remote control of the unit by wired cable:

- Remote on/off of the unit.
- Remote alarm reset to re-start the unit.
- Alarm or alert indications.
- Free customer contact.

With the optional extension board BE60, it is possible to get additional customized digital or analog inputs / outputs for remote control of the unit:

- Fault fans or pumps (dry contact).
- Operation indication at 100% on circuit 1 or 2 (dry contact).
- Dual water set-point management (dry contact).
- Force heating or cooling mode (24V AC input).
- Power limitation by disabling circuit 1 or 2 (24V AC input).
- Force unoccupied mode (24V AC input).
- Water set-point offset based on a 4-20mA signal. Note: non available with heat-pump units.

DIRECTIVES

The unit is built to meet European norms and standards & Eurovent certification performance standards.

- DI 97/23/CE Pressure Equipment Directive.
- DI 98/37/CE Machinery Directive.
- DI 73/23/CE Low Voltage Directive.
- DI 89/336/CE Electro Magnetic Compatibility Directive
- EN 378-2 Safety and Environmental Directive.
- **The European Restriction of the Use of Certain Hazardous Substances (RoHS).**

OPTIONS	DESCRIPTION	ADVANTAGES	MODELS
Low-pressure single-pump hydraulic module	Low-pressure single pump, regulating valve, Victaulic couplings, filter and all necessary hydraulic devices. Refer to specific chapter.	Quick start-up on job site. Available pressure around 150 kPa.	NAC 200 ► 640 NAH 200 ► 480
High-pressure single-pump hydraulic module	High-pressure single pump, regulating valve, Victaulic couplings, filter and all necessary hydraulic devices. Refer to specific chapter.	Quick start-up on job site. Available pressure around 250 kPa.	NAC 200 ► 640 NAH 200 ► 480
Low-pressure twin-pump hydraulic module	Low-pressure twin pumps, regulating valve, Victaulic couplings, filter and all necessary hydraulic devices. Refer to specific chapter.	Quick start-up on job site. Available pressure around 150 kPa.	NAC 200 ► 640 NAH 200 ► 480
High-pressure twin-pump hydraulic module	High-pressure twin pumps, regulating valve, Victaulic couplings, filter and all necessary hydraulic devices. Refer to specific chapter.	Quick start-up on job site. Available pressure around 250 kPa.	NAC 200 ► 640 NAH 200 ► 480
Partial heat recovery	Plate heat exchanger on each compressor circuit allowing recovery of 20% of the rejected heat	Allow free hot water production simultaneously with unit operation	NAC 200 ► 640 NAH 200 ► 300
Total heat recovery (Free hot water : 100% heat recovery)	Recovery brazed plates heat exchanger dual-circuit mounted in parallel to the air condensers allow 100% heat recovery in all outdoor air conditions.	Production of free hot water at the same time of the production of chilled water.	NAC 200 ► 640
Free cooling	Additional free cooling coils (one "V" or two "V" depending on needed capacity) with inverter fans and motorised valves.	Allow the chilled water to run through the free-cooling system, which uses less power and utilises the lower ambient air to cool the water.	NAC 200 ► 540
Winter operation (from +6°C down to -20°C) – Cooling only units	Unit fitted with electronic expansion valve and variable frequency driven fans. Select "anti-freeze protection" option if no glycol water	Increased operating range in cooling down to -20°C ambient temperature. (Standard on sizes 540/600/640/1080).	NAC 200 ► 480 NAC 680 ► 960
Brine operation (From +5°C down to -10°C)	Unit fitted with electronic expansion valve, variable frequency driven fans and reinforced evaporator and piping thermal insulation.	Increased operating range in cooling down to -10°C water leaving temperature for thermal storage or process cooling.	NAC 200 ► 1080
Anti-freeze protection (down to -20°C)	Resistance heaters on the evaporator, hydraulic module and partial heat recovery if selected. To be selected if no glycol water.	Evaporator and hydraulic module frost protection down to -20°C ambient temperature	NAC 200 ► 1080 NAH 200 ► 480
Anti-freeze protection of Total Heat Recovery exchanger	Resistance heater and insulation of the recovery exchanger, to be selected if no glycol water.	The recovery exchanger have frost protection down to -20°C ambient temperature.	NAC 200 ► 640
Heavy anti-corrosion coil treatment	Application of LenGuard treatment on the entire coil surface.	High corrosion resistance for severe industrial, marine and dirty environments.	NAC 200 ► 1080 NAH 200 ► 480
Rear protection grille	Metallic grille fitted at the back of the unit	Prevents the rear V-coil against possible damage	NAC 200 ► 640 NAH 200 ► 480

OPTIONS	DESCRIPTION	ADVANTAGES	MODELS
Soft starter	Electronic soft starter fitted into the electrical cabinet	Start-up current reduced by 15 % up to 30 %.	NAC 200 ► 1080* NAH 200 ► 480
Power Factor correction	Capacitors fitted into the unit	Cos phi correction up to 0.95 to reduce current and energy consumption.	NAC 200 ► 1080 NAH 200 ► 480
Electric meter	Active energy total counter, power factor, operating time counter, max. active power demand, ModBus.	This device allows monitoring of the unit electric power consumption on the unit and from a BMS	NAC 200 ► 1080 NAH 200 ► 480
Single main power connection	Electrical cabinet equipped with one single point of connection and power cut-off for the complete unit.	Allow easy electrical connection with one single cable instead of two cables	NAC 680 ► 1080
BE60 extension board for additional inputs/outputs	Electronic extension board with additional analog inputs (4), digital inputs (4) and digital outputs (4). See control manual.	Relay card for remote control and alarm report using dry contacts, 24 Vac or 4-20 mA signals.	NAC 200 ► 1080 NAH 200 ► 480
Modbus communication interface	Communication card using ModBus/JBus protocol with RS485 or TCP/IP connection.	Communication interface with a building management system.	NAC 200 ► 1080 NAH 200 ► 480
LonWorks® communication interface	Communication card using LonTalk® protocol with FTT-10A connection.	Communication interface with a building management system.	NAC 200 ► 1080 NAH 200 ► 480
BACnet® communication interface	Communication card using Bacnet® protocol with RS485 or TCP/IP connection.	Communication interface with a building management system.	NAC 200 ► 1080 NAH 200 ► 480

*except in case of main power connection option

ACCESSORIES	DESCRIPTION	ADVANTAGES	MODELS
Water filter	1000 microns water Y filter delivered with piping and flange connections.	This protection must be fitted in the customer water supply piping to protect the evaporator from any possible impurities.	NAC 200 ► 1080 NAH 200 ► 480
Flange connection	Two connections sleeves with victaulic groove and flange on opposite side.	Allow easy connection with flanges on customer side.	NAC 200 ► 1080 NAH 200 ► 480
Anti-vibration mounts	Rubber anti-vibration mounts to be mounted under the unit.	Reduction of the transmission of vibration to the ground and the general level.	NAC 200 ► 1080 NAH 200 ► 480
DC60 remote comfort display	Customer display located at 600 meters maximum from the unit.	Remote customer parameter reading and modification.	NAC 200 ► 1080 NAH 200 ► 480
DS60 service display	Plug and play display delivered with 1 meter cable and connector for quick connection on Climatic controller.	Display for service technicians only.	NAC 200 ► 1080 NAH 200 ► 480
Adalink™ supervision	Electronic board with RS485 cables, RJ11 phone cable, Ethernet cable and power supply cable.	Remote supervision of the unit via an intuitive web page.	NAC 200 ► 1080 NAH 200 ► 480

COOLING ONLY
R410A
NAC

NEOSYS		NAC	200	230	270	300	340	380
Cooling mode								
Cooling capacity ⁽¹⁾	kW		208,2	235,7	272,8	307,6	351,3	387,3
Total absorbed power ⁽¹⁾			72,1	85,7	106,7	106,9	125,6	149,1
EER ⁽¹⁾			2,89	2,75	2,56	2,88	2,80	2,60
ESEER ⁽²⁾			4,24	4,03	3,99	4,04	4,15	3,90
Comfort applications	Seasonal Energy Efficiency Ratio ⁽³⁾ SEER		3,83	3,85	3,82	3,89	3,89	3,99
	Seasonal energy efficiency ⁽⁴⁾ η_{s,c}		%	150	151	150	153	153
Process applications	Seasonal Energy Performance Ratio ⁽⁵⁾ SEPR - High temperature (7°C)		4,88	4,93	5,01	4,95	4,98	5,01
	Seasonal Energy Performance Ratio ⁽⁶⁾ SEPR - Medium temperature (-8°C)		3,20	3,26	3,50	3,30	3,40	3,50
Refrigeration circuit								
Number of circuit			2					
Refrigerant load per circuit (R410A)		kg	12,4/13	12,3/13	14,1/15	18,2/19,1	22,4/19,3	22,4/19,4
Type of expansion valve			Thermostatic expansion valve					
Compressors			Scroll - Hermetic					
Number of compressors			4	4	4	4	5	5
Capacity steps		%	31-62-81-100	34-68-84-100	28-57-78-100	27-53-73-100	18-41-59-82-100	20-40-60-80-100
Oil type			MOBIL EAL Arctic 22CC or ICI EMKARATE RL32CF					
Oil load per compressor		l	(3,2+6,8) + (3,2+6,8)	(3,2+6,3) + (3,2+6,3)	(6,8+6,3) + (6,8+6,3)	(6,3x2) + (6,8+6,3)	(6,8x3) + (6,3x2)	(6,3x3) + (6,3x2)
Condenser			Microchannel Aluminium Tube and fins					
Number of condenser			4	4	4	6	6	6
Fan & Motor			Variable speed fans					
Number of fans			4	4	4	6	6	6
Diameter		mm	800					
Maximum speed			Variable speed - 900 rpm maximum					
Nominal air flow (100%)		m ³ /h	87 200	87 200	87 200	130 800	130 800	130 800
Total motor power input (900 rpm)		kW	6,4	6,4	6,4	9,6	9,6	9,6
Evaporator			AISI 304 stainless steel plate brazed with copper heat exchanger					
Water flow rate ⁽¹⁾		m ³ /h	35,8	40,6	46,9	52,9	60,4	66,6
Water volume		l	13	13	16	24	35	35
Pressure drop ⁽¹⁾		kPa	43,0	54,1	55,9	48,1	34,7	41,6
Water operating pressure			600					
Hydraulic connections			Victaulic					
Water inlet/outlet			4"	4"	4"	4"	5"	5"
Electrical data			400V / III / 50 Hz					
Start-up intensity		A	393,9	446,5	475,7	498,0	527,9	572,0
Maximum current			166,5	195,8	225,0	247,3	277,2	321,3

(1) EUROVENT certified data, in accordance with standard EN14511 :
Water inlet/outlet temperature = 12°C / 7°C
Outdoor air temperature = 35°C.

(2) ESEER following Eurovent calculation method, in accordance with standard EN14511

(3) SEER in accordance with standard EN14825.

(4) Following ecodesign regulation nr **EU 2016/2281** on space cooling, normalized leaving water temperature at 7°C, in accordance with standard EN14825.

(5) Following ecodesign regulation nr **EU 2016/2281** on process cooling units, normalized leaving water temperature at 7°C, in accordance with standard EN14825.

(6) Following ecodesign regulation nr **EU 2015/1095** on process cooling chillers, normalized leaving water temperature at -8°C, in accordance with standard EN14825.



COOLING ONLY

R410A

NAC

NEOSYS		NAC	420	480	540	600	640
Cooling mode							
Cooling capacity ⁽¹⁾	kW		429,6	489,9	530,9	605,0	626,9
Total absorbed power ⁽¹⁾			152,3	174,3	201,9	219,1	226,1
EER ⁽²⁾			2,82	2,81	2,63	2,76	2,77
ESEER ⁽³⁾			4,19	4,01	4,0	4,15	4,17
Comfort applications	Seasonal Energy Efficiency Ratio ⁽³⁾ SEER		4,12	4,11	4,17	4,15	4,17
	Seasonal energy efficiency ⁽⁴⁾ η_{s,c}		%	162	161	164	163
Process applications	Seasonal Energy Performance Ratio ⁽⁵⁾ SEPR - High temperature (7°C)		5,02	5,04	5,02	5,01	5,01
	Seasonal Energy Performance Ratio ⁽⁶⁾ SEPR - Medium temperature (-8°C)		3,50	3,60	3,60	3,70	3,70
Refrigeration circuit							
Number of circuit			2				
Refrigerant load per circuit (R410A)		kg	34	34	34	42,5	42,5
Type of expansion valve			Thermostatic expansion valve		Electronic expansion valve		
Compressors			Scroll - Hermetic				
Number of compressors			6				
Capacity steps		%	14-33-48-67-81-100	17-33-50-67-83-100	18-33-51-67-85-100	17-33-50-67-83-100	17-33-50-67-83-100
Oil type			MOBIL EAL Arctic 22CC or ICI EMKARATE RL32CF				
Oil load per compressor			(6,3x3) + (6,8x3)	(6,3x3) + (6,3x3)	(6,3x3) + (6,3x3)	(6,3x3) + (6,3x3)	(6,3x3) + (6,3x3)
Condenser			Microchannel aluminium tube and fins - Air cooled				
Number of condenser			8	8	8	10	10
Fan & Motor			Variable speed fans				
Number of fans			8	8	8	10	10
Diameter		mm	800				
Maximum speed			Variable speed - 900 rpm maximum				
Nominal air flow (100%)		m ³ /h	174 400	174 400	174 400	218 000	218 000
Total motor power input (900 rpm)		kW	12,8	12,8	12,8	16	16
Evaporator			AISI 304 stainless steel plate brazed with copper heat exchanger				
Water flow rate ⁽¹⁾		m ³ /h	73,9	84,3	91,3	104,1	107,9
Water volume			35	43	43	52	56
Pressure drop ⁽¹⁾		kPa	50,3	48,8	56,7	59,0	58,4
Water operating pressure				600			
Hydraulic connections			Victaulic				
Water inlet/outlet			5"	5"	6"	6"	6"
Electrical data			400V / III / 50 Hz				
Start-up intensity		A	594,8	638,9	765,9	817,0	817,0
Maximum current			344,1	388,2	431,7	482,8	482,8

- (1) EUROVENT certified data, in accordance with standard EN14511 :
Water inlet/outlet temperature = 12°C / 7°C
Outdoor air temperature = 35°C.
- (2) ESEER following Eurovent calculation method, in accordance with standard EN14511
- (3) SEER in accordance with standard EN14825.

- (4) Following ecodesign regulation nr **EU 2016/2281** on space cooling, normalized leaving water temperature at 7°C, in accordance with standard EN14825.
- (5) Following ecodesign regulation nr **EU 2016/2281** on process cooling units, normalized leaving water temperature at 7°C, in accordance with standard EN14825.

- (6) Following ecodesign regulation nr **EU 2015/1095** on process cooling chillers, normalized leaving water temperature at -8°C, in accordance with standard EN14825.

COOLING ONLY
R410A
NAC

NEOSYS		NAC	680	760	840	960	1080
Cooling mode							
Cooling capacity ⁽¹⁾	kW		702,6	774,7	859,1	979,8	1061,9
Power input ⁽¹⁾			251,3	298,2	304,6	348,7	403,8
EER ⁽²⁾			2,80	2,60	2,82	2,81	2,63
ESEER ⁽³⁾			4,15	3,91	4,21	4,01	4,0
Comfort applications	Seasonal Energy Efficiency Ratio ⁽³⁾ SEER		4,14	4,14	4,22	4,11	4,11
	Seasonal energy efficiency ⁽⁴⁾ η_{s,c}		%	163	163	166	162
Process applications	Seasonal Energy Performance Ratio ⁽⁵⁾ SEPR - High temperature (7°C)		5,05	5,03	5,01	5,04	5,01
	Seasonal Energy Performance Ratio ⁽⁶⁾ SEPR - Medium temperature (-8°C)		3,60	3,50	3,50	3,60	3,60
Refrigeration circuit							
Number of circuit			4				
Refrigerant load per circuit (R410A)		kg	22,4/19,3/ 22,4/19,3	22,4/19,4/ 22,4/19,4	34	34	34
Type of expansion valve			Thermostatic expansion valve				Electronic expansion valve
Compressors							
Number of compressors			10	10	12	12	12
Type of compressor			Scroll - Hermetic				
Capacity steps		%	9-18-30-41- 50-59-70-82- 91-100	10-20-30-40- 50-60-70-80- 90-100	8-15-24-33- 41-48-58-67- 74-82-91-100	8-17-25-33- 42-50-58-67- 75-83-92-100	8-15-24-33-41-48- 58-67-74-82-91- 100
Oil type			MOBIL EAL Arctic 22CC or ICI EMKARATE RL32CF				
Oil load per compressor		l	[(6,8x3) + (6,3x2)] x 2	[(6,3x3) + (6,3x2)] x 2	[(6,3x3) + (6,8x3)] x 2	[(6,3x3) + (6,3x3)] x 2	
Condenser			Microchannel aluminium tube and fins				
Number of condenser			12	12	16	16	16
Fan & Motor			Variable speed fans				
Number of fans			12	12	16	16	16
Diameter		mm	800				
Maximum speed			Variable speed - 900 rpm maximum				
Nominal air flow (100%)		m ³ /h	261 600	261 600	348 800	348 800	348 800
Total motor power input (900 rpm)		kW	19,2	19,2	25,6	25,6	25,6
Evaporator			AISI 304 stainless steel plate brazed with copper heat exchanger				
Water flow rate ⁽¹⁾		m ³ /h	120,9	133,3	147,8	168,6	182,7
Water volume		l	275	290	300	335	345
Pressure drop ⁽¹⁾		kPa	57,0	51,3	56,0	66,0	71,0
Water operating pressure			600	600	600	600	600
Hydraulic connections			Victaulic				
Water inlet/outlet			8"				
Electrical data			400V / III / 50 Hz				
Start-up intensity		A	805,2	893,3	939,0	1027,1	1197,6
Maximum current			554,5	642,6	688,3	776,4	863,4

(1) EUROVENT certified data, in accordance with standard EN14511 :
Water inlet/outlet temperature = 12°C / 7°C
Outdoor air temperature = 35°C.

(2) ESEER following Eurovent calculation method, in accordance with standard EN14511

(3) SEER in accordance with standard EN14825.

(4) Following ecodesign regulation nr **EU 2016/2281** on space cooling, normalized leaving water temperature at 7°C, in accordance with standard EN14825.

(5) Following ecodesign regulation nr **EU 2016/2281** on process cooling units, normalized leaving water temperature at 7°C, in accordance with standard EN14825.

(6) Following ecodesign regulation nr **EU 2015/1095** on process cooling chillers, normalized leaving water temperature at -8°C, in accordance with standard EN14825.



COOLING ONLY



Acoustic data

NEOSYS	NAC	200	230	270	300	340	380
Active Acoustic Attenuation System™							
Global sound power level ⁽¹⁾	dB(A)	89,2	89,3	89,7	91,2	91,3	91,4
Sound pressure level 10 meters from the unit		57	57	58	59	59	59
Minimum global sound power level with A ³ system ⁽³⁾		82,2	82,8	84,4	85,0	85,5	85,9
Minimum sound pressure level with A ³ system ⁽³⁾ 10 meters from the unit		51	52	54	54	55	55

NEOSYS	NAC	420	480	540	600	640
Active Acoustic Attenuation System™						
Global sound power level ⁽¹⁾	dB(A)	92,5	92,6	93,0	94,0	94,0
Sound pressure level 10 meters from the unit		61	61	61	62	62
Minimum global sound power level with A ³ system ⁽³⁾		86,5	86,8	88,2	89,3	89,3
Minimum sound pressure level with A ³ system ⁽³⁾ 10 meters from the unit		56	56	57	59	59

NEOSYS	NAC	680	760	840	960	1080
Active Acoustic Attenuation System™						
Global sound power level ⁽¹⁾	dB(A)	94,3	94,4	95,5	95,6	96,0
Sound pressure level 10 meters from the unit		62	62	64	64	64
Minimum global sound power level with A ³ system ⁽³⁾		88,5	88,9	89,5	89,8	91,2
Minimum sound pressure level with A ³ system ⁽³⁾ - 10 meters from the unit		58	58	59	59	60

(1) All data are at Eurovent condition,

Gross cooling capacity with 12/7°C water temperature and 35°C air ambient.
 Gross heating capacity with 7°C air inlet temperature and 40/45°C water temperature.
 EER and COP according to EN14511 Eurovent calculation method

Dimensional data

NEOSYS	NAC	200	230	270	300	340	380	420	480	540	600	640
Dimensions												
Length	mm	3590			4620			5650			6680	
Width		2280			2280			2280			2280	
Height		2025			2025			2025			2025	
Footprint	m ²	8,2			10,5			12,9			15,2	
Operating weight	kg	1983	2011	2278	2676	3003	3045	3580	3661	3712	4152	4175
Shipping weight		1961	1989	2253	2643	2955	2997	3532	3604	3655	4086	4105

NEOSYS	NAC	680	760	840	960	1080					
Dimensions											
Length	mm	9040			11100						
Width		2280			2280						
Height		1964			1964						
Footprint	m ²	20,6			25,3						
Operating weight	kg	6770		6854		7981		8141		8229	
Shipping weight		6495		6564		7681		7806		7884	

HEAT PUMP
R410A
NAH

NEOSYS		NAH	200	230	270	300
Cooling mode						
Cooling capacity ⁽¹⁾		kW	191	217	271	295
Total absorbed power ⁽¹⁾			73,5	86,7	106,7	117,0
Full load amps ⁽¹⁾		A	127,9	150,7	185,6	203,5
EER ⁽¹⁾			2,60	2,50	2,54	2,52
ESEER ⁽²⁾			4,00	3,76	3,99	3,94
Comfort applications	Seasonal Energy Efficiency Ratio ⁽⁴⁾ SEER		3,93	3,91	3,92	4,00
	Seasonal energy efficiency ⁽³⁾ η_{s,c}	%	154	154	154	157
Process applications	Seasonal Energy Performance Ratio ⁽⁵⁾ SEPR - High temperature (7°C)		5,20	5,04	5,06	5,01
	Seasonal Energy Performance Ratio ⁽⁶⁾ SEPR - Medium temperature (-8°C)		3,15	3,20	3,02	3,09
Heating mode						
Heating capacity ⁽¹⁾		kW	219	235	291	339
Power input ⁽¹⁾			71,7	84,0	104,3	112,7
Full load amps ⁽¹⁾		A	125,9	145,3	172,8	192,5
COP ⁽³⁾			3,05	2,80	2,78	3,01
Comfort applications	Seasonal energy efficiency ⁽⁸⁾ SCOP		3,44	3,32	3,39	3,45
	Seasonal energy efficiency ⁽⁷⁾ η_{s,h}	%	134	130	132	135
Seasonal energy efficiency class ⁽⁹⁾			A+			
Compressors			Scroll - Hermetic			
Number of compressors			4			
Capacity steps		%	31 - 62 - 81 - 100	34 - 68 - 84 - 100	28 - 57 - 78 - 100	25 - 50 - 75 - 100
Oil type			MOBIL EAL Arctic 22CC or ICI EMKARATE RL32CF			
Oil load per compressor			(3,2+6,8) + (3,2+6,8)	(3,2+6,3) + (3,2+6,3)	(6,8+6,3) + (6,8+6,3)	(6,3x2) + (6,3x2)
Refrigeration circuit						
Number of circuit			2			
Refrigerant load per circuit (R410A)		kg	28	28	40	42
Type of expansion valve			Thermostatic expansion valve			
Condenser			Copper tube - Aluminium fin - Air-cooled			
Number of condenser			4	4	6	6
Fan & Motor			Variable speed fans			
Number of fans			4	4	6	6
Diameter		mm	800			
Maximum speed			Variable speed - 900 rpm maximum			
Nominal air flow (100%)		m ³ /h	76 000	76 000	114 000	114 000
Total motor power input		kW	6,4	6,4	9,6	9,6
Evaporator			AISI 304 stainless steel plate brazed with copper heat exchanger			
Water flow ⁽¹⁾		m ³ /h	32,9	37,3	46,6	50,8
Water volume			20	20	23,2	23,2
Pressure drop ⁽¹⁾		kPa	36,7	46,4	55,2	44,7
Water operating pressure			600			
Hydraulic connections			Victaulic			
Water inlet/outlet			4"			
Electrical data			400V / III / 50 Hz			
Starting current		A	393,9	446,5	483,3	512,7
Maximum current			166,5	195,8	232,6	262,0

(1) EUROVENT certified data, in accordance with standard EN14511 :

Water inlet / outlet temperature = 12 °C / 7 °C
Outdoor air temperature = 35 °C.

(2) ESEER following Eurovent calculation method, in accordance with standard EN14511

(3) Following ecodesign regulation nr **EU 2016/2281** on space cooling, normalized leaving water temperature at 7 °C, in accordance with standard EN14825.

(4) SEER in accordance with standard EN14825.

(5) Following ecodesign regulation nr **EU 2016/2281** on process cooling units, normalized leaving water temperature at 7°C, in accordance with standard EN14825.

(6) Following ecodesign regulation nr **EU 2015/1095** on process cooling chillers, normalized leaving water temperature at -8°C, in accordance with standard EN14825

(7) SCOP in accordance with standard EN14825. Heating mode performance is defined for average climate.

(8) Following ecodesign regulation nr **EU 813/2013** on space heaters, normalized leaving water temperature at 7°C, in accordance with standard EN14825, average climate.

(9) Following energy labelling regulation nr **EU 811/2013** on space heaters.



HEAT PUMP

R410A

NAH

NEOSYS		NAH	340	380	420	480
Cooling mode						
Cooling capacity ⁽¹⁾		kW	324	361	397	454
Total absorbed power ⁽¹⁾			128,4	133,1	155,1	179,4
Full load amps ⁽¹⁾		A	223,3	231,4	269,7	311,9
EER ⁽¹⁾			2,52	2,71	2,56	2,53
ESEER ⁽²⁾			4,01	4,08	3,86	4,14
Comfort applications	Seasonal Energy Efficiency Ratio ⁽⁴⁾ SEER		4,23	4,20	4,12	4,16
	Seasonal energy efficiency ⁽³⁾ η_{s,h}		%	166	165	162
Process applications	Seasonal Energy Performance Ratio ⁽⁵⁾ SEPR - High temperature (7°C)		5,21	5,25	5,11	5,12
	Seasonal Energy Performance Ratio ⁽⁶⁾ SEPR - Medium temperature (-8°C)		3,23	3,09	3,11	3,19
Heating mode						
Heating capacity ⁽¹⁾		kW	363	404	452	499
Power input ⁽¹⁾			121,3	132,9	151,7	169,5
Full load amps ⁽¹⁾		A	125,9	145,3	172,8	192,5
COP ⁽³⁾			3,00	3,04	2,98	2,95
Comfort applications	Seasonal energy efficiency ⁽⁸⁾ SCOP		3,47	3,39	3,33	3,35
	Seasonal energy efficiency ⁽⁷⁾ η_{s,h}		%	136	132	130
Seasonal energy efficiency class ⁽⁹⁾			A+			
Compressors			Scroll - Hermetic			
Number of compressors			5	6	6	6
Capacity steps		%	18 - 41 - 59 - 82 - 100	17 - 33 - 50 - 67 - 83 - 100	14 - 33 - 48 - 67 - 81 - 100	17 - 33 - 50 - 67 - 83 - 100
Oil type			MOBIL EAL Arctic 22CC or ICI EMKARATE RL32CF			
Oil load per compressor		l	(6,8 x 3) + (6,3 x 2)	(6,8 x 3) + (6,8 x 3)	(6,3 x 3) + (6,8 x 3)	(6,3 x 3) + (6,3 x 3)
Refrigeration circuit						
Number of circuit			2			
Refrigerant load per circuit (R410A)		kg	42	50	52	52
Type of expansion valve			Thermostatic expansion valve			
Condenser			Copper tube - Aluminium fin - Air-cooled			
Number of condenser			6	8	8	8
Fan & Motor			Variable speed fans			
Number of fans			6	8	8	8
Diameter		mm	800			
Maximum speed			Variable speed - 900 rpm maximum			
Nominal air flow (100%)		m ³ /h	114 000	152 000	152 000	152 000
Total motor power input		kW	9,6	12,8	12,8	12,8
Evaporator			AISI 304 stainless steel plate brazed with copper heat exchanger			
Water flow ⁽¹⁾		m ³ /h	55,7	62,1	68,4	78,1
Water volume		l	34,6	34,6	34,6	42,7
Pressure drop ⁽¹⁾		kPa	29,8	36,5	43,6	42,3
Water operating pressure			600			
Hydraulic connections			Victaulic			
Water inlet/outlet		Inches	5"			
Electrical data			400V / III / 50 Hz			
Starting current		A	527,9	579,6	594,8	638,9
Maximum current			277,2	328,9	344,1	388,2

- (1) EUROVENT certified data, in accordance with standard EN14511 :
Water inlet / outlet temperature = 12 °C / 7 °C
Outdoor air temperature = 35 °C.
- (2) ESEER following Eurovent calculation method, in accordance with standard EN14511
- (3) Following ecodesign regulation nr **EU 2016/2281** on space cooling, normalized leaving water temperature at 7 °C, in accordance with standard EN14825.

- (4) SEER in accordance with standard EN14825.
- (5) Following ecodesign regulation nr **EU 2016/2281** on process cooling units, normalized leaving water temperature at 7°C, in accordance with standard EN14825.
- (6) Following ecodesign regulation nr **EU 2015/1095** on process cooling chillers, normalized leaving water temperature at -8°C, in accordance with standard EN14825

- (7) SCOP in accordance with standard EN14825. Heating mode performance is defined for average climate.
- (8) Following ecodesign regulation nr **EU 813/2013** on space heaters, normalized leaving water temperature at 7°C, in accordance with standard EN14825, average climate.
- (9) Following energy labelling regulation nr **EU 811/2013** on space heaters.



HEAT PUMP



NAH

Acoustic data

NEOSYS	NAH	200	230	270	300	340	380	420	480
		Active Acoustic Attenuation System™							
Global sound power level ⁽¹⁾	dB(A)	89,2	89,3	91,1	91,2	91,3	92,4	91,5	91,6
Sound pressure level 10 meters from the unit		57	57	59	59	59	61	61	61
Minimum global sound power level with A ³ system ⁽³⁾		82,2	82,8	84,9	85,0	85,5	86,1	86,2	86,5
Minimum sound pressure level with A ³ system ⁽³⁾ 10 meters from the unit		51	52	54	54	55	56	56	56

(1) All data are at Eurovent condition,

Gross cooling capacity with 12/7°C water temperature and 35°C air ambient.
Gross heating capacity with 7°C air inlet temperature and 40/45°C water temperature.
EER and COP according to EN14511 Eurovent calculation method

Dimensional data

NEOSYS	NAH	200	230	270	300	340	380	420	480
Dimensions									
Length	mm	3590		4620			5650		
Width		2280		2280			2280		
Height		2025		2025			2025		
Footprint	m ²	8,2		10,5			12,9		
Operating weight	kg	2176	2175	2906	3380	3349	4020	4066	4148
Shipping weight		2154	2153	2881	3347	3301	3972	4020	4091

EVAPORATOR AND CONDENSER CURVES

		Curves		
		Evaporator	Evaporator pressure drop in units with total heat recovery option	Condenser
NAC/NAH	200	A	B	B
	230	A	C	C
	270	B	C	C
	300	C	C	D
	340	D	C	D
	380	D	C	E
	420	D	C	E
	480	E	G	G
NAC	540	E	J	J
	600	F	J	J
	640	G	J	J
	680	H	-	
	760	H	-	
	840	H	-	
	960	I	-	
	1080	I	-	

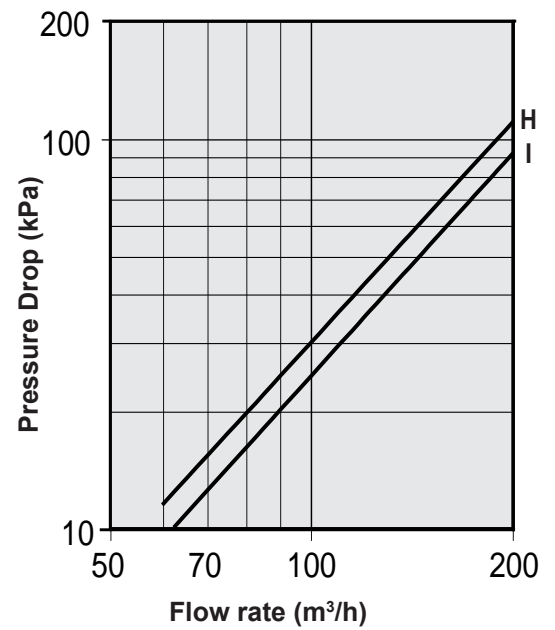
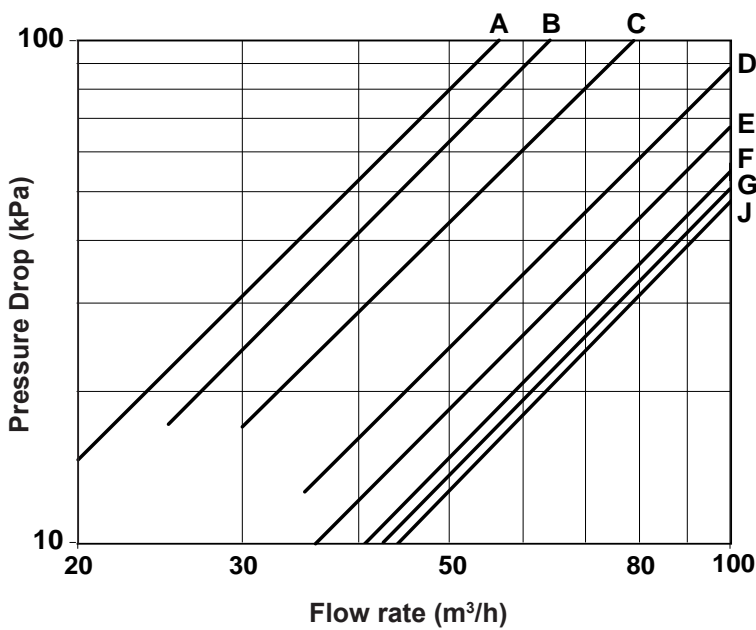

NEOSYS	$\Delta P = a X^b$	
	a	b
200/230	0,057	1,8516
270	0,0419	1,8695
300	0,0333	1,8333
340/380/420	0,0175	1,8509
480/540	0,0124	1,8669
600	0,009	1,892
640	0,0082	1,8953
540/600/640	0,0072	1,9104

NEOSYS	$\Delta P = a X^b$	
	a	b
680	0,0056	1,8666
760	0,0056	1,8666
840	0,0056	1,8666
960	0,0042	1,886
1080	0,0042	1,886

Pressure drops are given for information only. A tolerance of +/- 20 kPa must be considered when selecting water pumps.

FILTER CURVE

NAC/NAH	Curve	NAC	Curve
200	L	540	N
230		600	
270		640	
300		680	
340	M	760	O
380		840	
420		960	
480		1080	

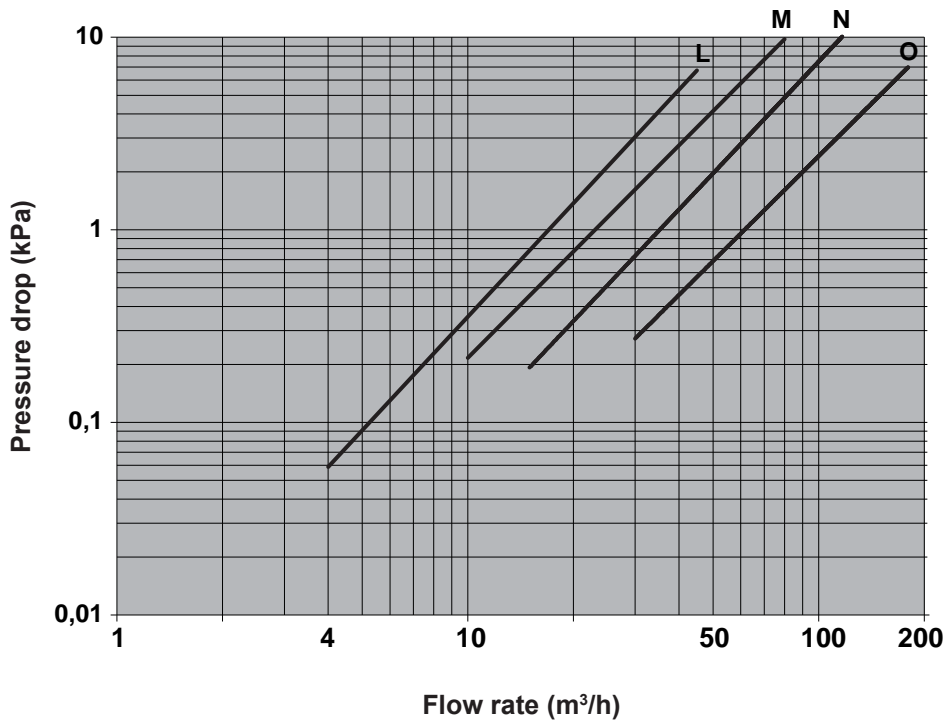

Size of the filter mesh: 1 mm

NEOSYS	$\Delta P = a X^b$	
	a	b
200/230/270/300	0,00332	1,7409
340/380/420/480	0,0000011	3,1026
540/600/640	8,00E-09	4,023
680/760/840/960/1080	0,0000000005	4,2717

Pressure drops are given for information only. A tolerance of +/- 20 kPa must be considered when selecting water pumps.

NAC		200	230	270	300	340	380	420	480	540	600	640
NAH										-	-	-
Nominal water flow	m ³ /h	35,8	40,5	46,9	52,9	60,4	66,6	73,9	84,3	91,3	104,0	107,8
Single pump												
Available static pressure ⁽¹⁾	kPa	101	119	89	127	125	144	125	107	146	133	130
Double pump												
Available static pressure ⁽¹⁾	kPa	80	92	82	119	116	136	115	95	133	115	110
Single pump HP												
Available static pressure ⁽¹⁾	kPa	191	218	201	207	215	202	214	192	230	215	212
Double pump HP												
Available static pressure ⁽¹⁾	kPa	171	204	203	206	213	198	202	171	213	191	186
Expansion vessel												
Volume	l	50										
Maximum pressure	kPa	400										
Gross Weight	kg	12,2										

(1) : Pump external static pressure - Evaporator pressure drop

PUMP PRESSURE CURVES

**Low pressure
Single pump**

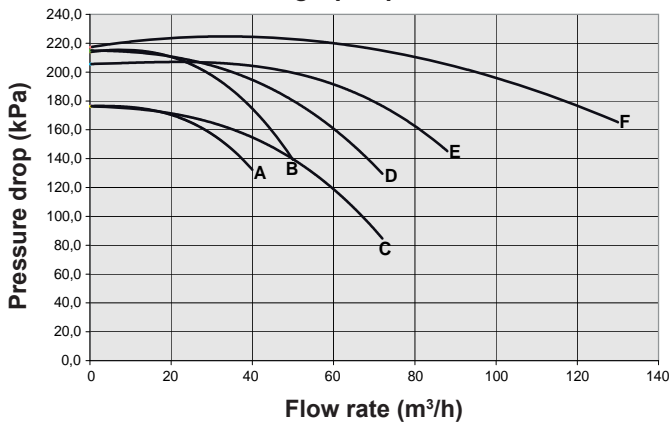

**High pressure
Single pump**

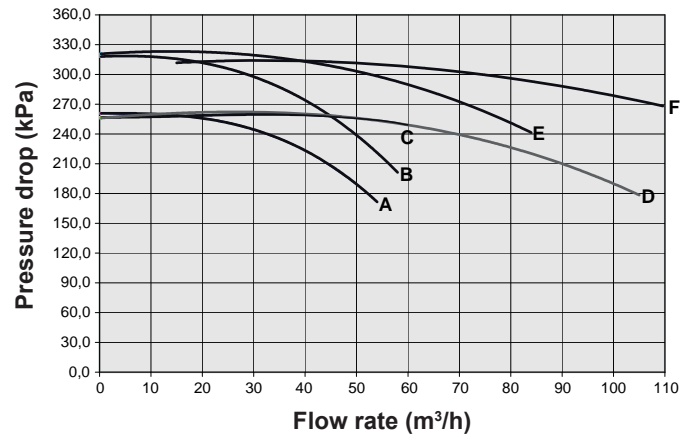

**Low pressure
Double pump**

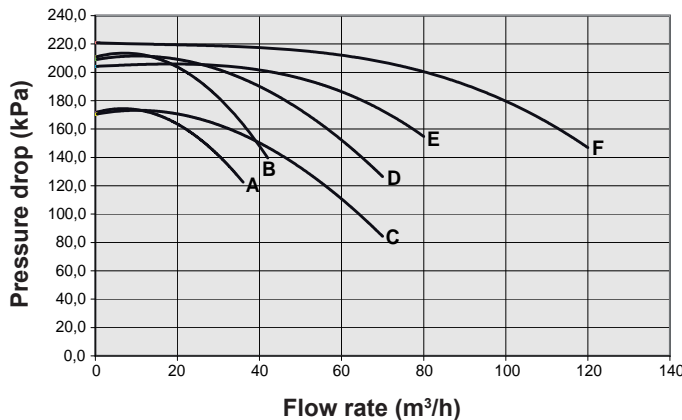

**High pressure
Double pump**

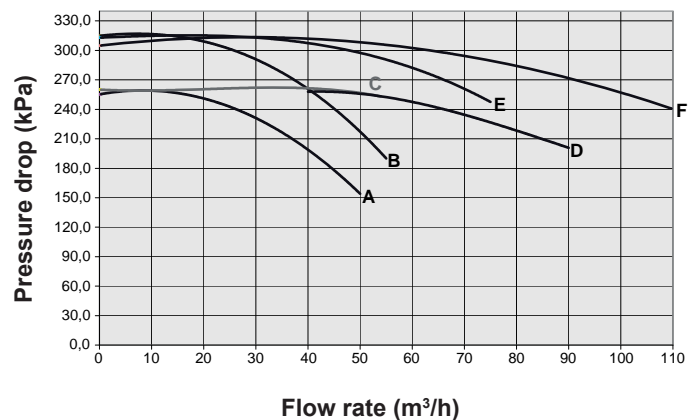

A	NAC/NAH 200	D	NAC/NAH 300/340
B	NAC/NAH 230	E	NAC/NAH 380/420/480
C	NAC/NAH 270	F	NAC 540/600/640

A	NAC/NAH 200	D	NAC/NAH 300/340/380
B	NAC/NAH 230	E	NAC/NAH 420/480
C	NAC/NAH 270	F	NAC 540/600/640

UNIT WITH HYDRAULIC MODULE

NAC/NAH
200 - 230 - 270 - 300

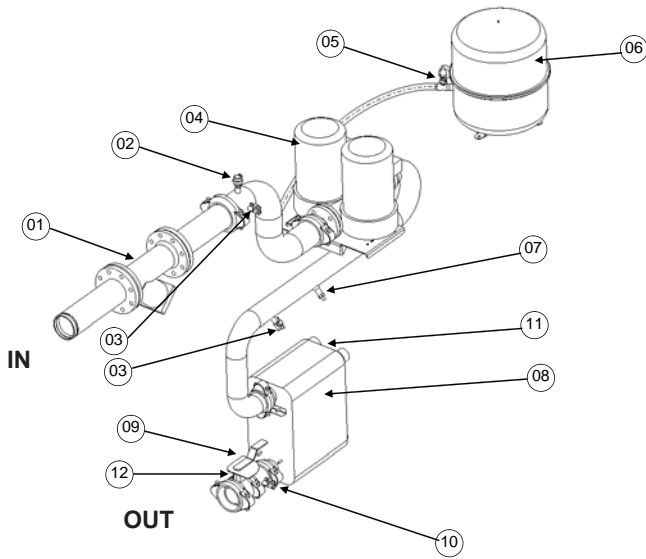

NAC 340 - 380 - 420 - 480 - 540 - 600 - 640
NAH 340 - 380 - 420 - 480

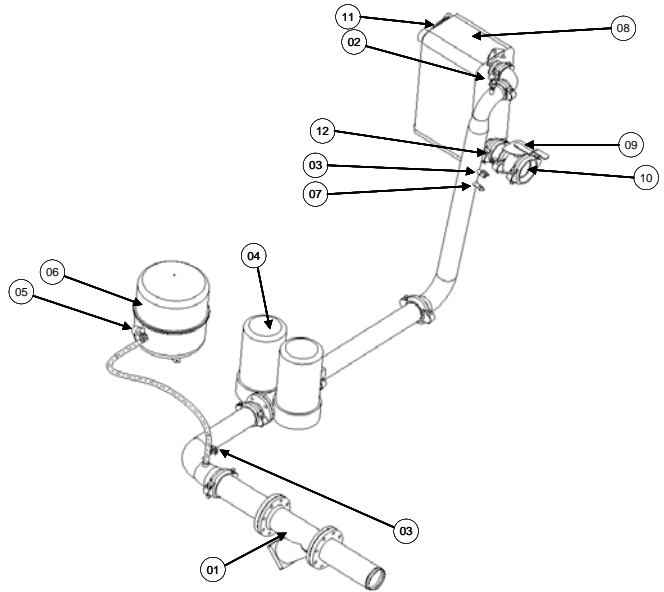

01	Water filter (item supplied loose)	07	Electronic flow switch
02	Air purge	08	Plate heat exchanger
03	Pressure tap	09	Setting valve
04	Pump	10	Pressure tap and drain valve
05	Safety valve with manometer	11	Return temperature sensor
06	Expansion vessel	12	Supply temperature sensor

MINIMUM WATER CONTENT OF AN INSTALLATION

Thanks to multi step capacity control and smart anti-short compressor cycling, NEOSYS can work with minimum water loop volume as defined here below. This can eliminate the need for a buffer tank in most of air-conditioning applications (e.g. NEOSYS application with fan-coil units).

$$V_{\text{mini}} = 86 \times Q / (N_{\text{stages}} \times Dt)$$

Where :	V	Minimum water content of the installation
	Q	Cooling capacity of the chiller
	Nstage	Number of control steps available in the unit
	Dt	Maximum acceptable temperature rise (Dt = 6°C for an air conditioning application)

Important note: In case NEOSYS is used in air-conditioning applications with a short water system (e.g. NEOSYS application with air handling units) or in case NEOSYS is used for industrial process cooling, it is mandatory to use a buffer tank.

MINIMUM WATER CONTENT OF AN INSTALLATION

Unit Size	Number of stages	Mini water volume (l)
NAC		
200	4	717
230	4	824
270	4	968
300	4	1075
340	5	975
380	5	1089
420	6	1003
480	6	1147
540	6	1290
600	6	1433
640	6	1529
680	10	975
760	10	1089
840	12	1003
960	12	1147
1080	12	1290

Unit Size	Number of stages	Mini water volume (l)
NAH		
200	4	717
230	4	824
270	4	968
300	4	1075
340	5	975
380	6	908
420	6	1003
480	6	1147

MAXIMUM WATER CONTENT OF AN INSTALLATION

The maximum water content of the installation is determined by the capacity of the expansion vessel.

On units fitted with a standard Hydraulic Module it is possible to determine the maximum water content of the installation.

Unit Size	Expansion vessel volume	Pressure in the expansion vessel	Max. volume clear water (l)		Max. volume Glycol water (l)	
			Static pressure		Static pressure	
			5 m	10 m	5 m	10 m
200-230-270 300-340-380 420-480 540 600-640	50 l	1,5 Bar	5 230 l	4 180 l	4 020 l	3 210 l

GLYCOL CORRECTION FACTOR

Minimum ambient temperature or water outlet temperature	Ethylene glycol	Pressure drop	Water flow	CAPACITIES	
				Cooling	Heating
+ 5°C ► 0°C	10%	1,05	1,02	0,99	0,994
0°C ► -5°C	20%	1,10	1,05	0,98	0,993
- 5°C ► -10°C	30%	1,15	1,08	0,97	0,99
- 10°C ► -15°C	35%	1,18	1,10	0,96	0,987

Example : 10% glycol
 Minimum flow : 1,19 m³/h x 1,02
 Pressure drop x 1,07
 System capacity x 0,99

MINIMUM WATER FLOW THROUGH THE EVAPORATOR

In case of installation with fixed speed pump, to prevent from freezing risk, the flow rate through the evaporator must be higher than the minimum flow given in the table below.

In case of variable primary flow, the pump speed must be controlled through the CLIMATIC control. Additionally, the hydraulic system must be properly designed and balanced to ensure a right water flow distribution through the chiller evaporator and the terminal units. This is especially important when the system is designed with fan coils equipped with two-way valves. When the two-way valves are closing in response to building load change, it is important that the system is designed to ensure a minimum evaporator flow that is always minimum 60% of the chiller's design flow rate. This can be done with a bypass from chilled water supply to chilled water return opened via a signal from a flow meter.

Additionally, some terminals can be fitted with three way control valves in order to ensure the flow will not drop below the minimum value at any load condition as indicated in the table below.

Models	Capacity (kW)	Water flow rate (m ³ /h)		
		Minimum (with fixed and eDrive™ variable speed pump)	Nominal	Maximum
200	208	21,5	35,8	57,9
230	236	24,4	40,6	57,9
270	273	28,1	46,9	57,9
300	308	31,7	52,9	126,4
340	351	36,2	60,4	126,4
380	387	40,0	66,6	126,4
420	430	44,3	73,9	126,4
480	490	50,6	84,3	126,4
540	531	54,8	91,3	126,4
600	605	62,5	104,1	126,4
640	627	64,7	107,9	126,4
680	702	72,6	121,0	252,9
760	774	80,1	133,4	252,9
840	860	88,8	148,0	252,9
960	980	101,3	168,8	252,9
1080	1062	109,7	182,9	252,9

Important note : The water flow must not vary by more than 10% per minute. If the flow rate changes more rapidly, the system should contain a minimum of 6,5 litres of water per kW instead of 3 l/kW.

eDrive™ TECHNOLOGY, THE RIGHT CHOICE TO SAVE 75% OF PUMP ENERGY COSTS.

LENNOX offers the eDrive, a variable speed drive pump option (with single or double pump) which modulates the water flow through the evaporator and reduces energy costs. This option is available on chillers and heat pumps from 20 to 1000 kW.

In a water system, one major contributor to annual energy consumption is the pump motor. Pumping energy cost can represent 20% of the total cost of owning a chiller. This ratio can be even bigger for a heat-pump.

eDrive™ variable speed driven pump is contributing to continuous Lennox efforts to save energy while exploring possibilities to reduce installation cost.

eDrive™ variable speed driven pump benefits:

- Cost savings on the energy consumption especially at part-load conditions and during off period. 75% of this energy could be saved !
- Cost savings on the initial system cost. Fewer pumps and piping connections than primary–secondary systems, terminal units equipped with two-way control valves instead of three-way valves, elimination of water flow set valve.
- Flexibility and accuracy in the pump operation control (smooth start and stop, gradual change of speed, accuracy and stability of control)
- Reduction of the repeated stress on the pump and piping resulting in longer equipment life time (elimination of the «hammer blow» in pipes).
- Elimination of the start-up current thanks to variable frequency drive that controls a gradual pump motor supply.

Designing a VWF chilled water plant that performs reliably at all load conditions requires careful attention to chiller design. Thanks to the newest generation of chiller controllers and intensive testing, NEOSYS can now reliably maintain the desired chilled water temperature with a flow range from 60% to 100% that gives up to 75% annual energy savings.

LENNOX eDrive™ Technology modulates the Water Flow especially in Part-Load Conditions through a Specific Algorithm and a Variable Frequency Driver.

Typical cost split in a chiller through 15-year lifespan

Chiller with fixed speed pump

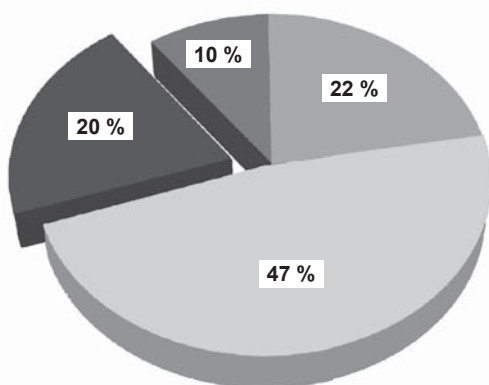

Chiller with variable speed pump

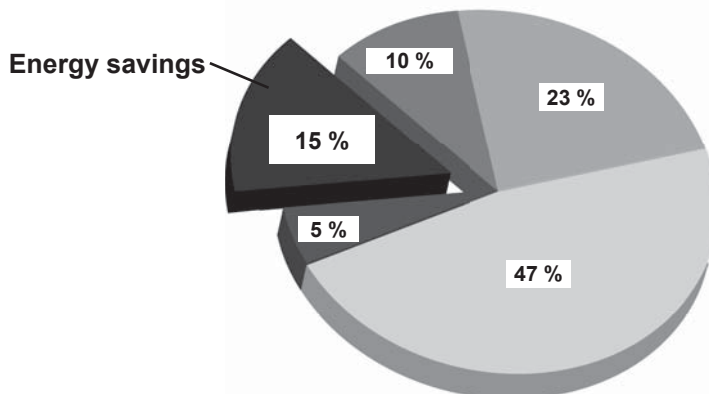

Cooling energy cost	Maintenance cost
Equipment cost	Pump energy cost

eDrive™ VARIABLE WATER FLOW SAVES YOUR MONEY IN THE ENERGY COST

- Through the elimination of the energy normally lost in the water flow control valve during unit full-load operation (Variable water flow = perfect pump curve adjustment to the required nominal water flow and delta P)
- Through pump rotation speed reduction during unit part-load operation.
- Thanks to pump running at minimum speed during Chiller “off” period (night, unoccupied)

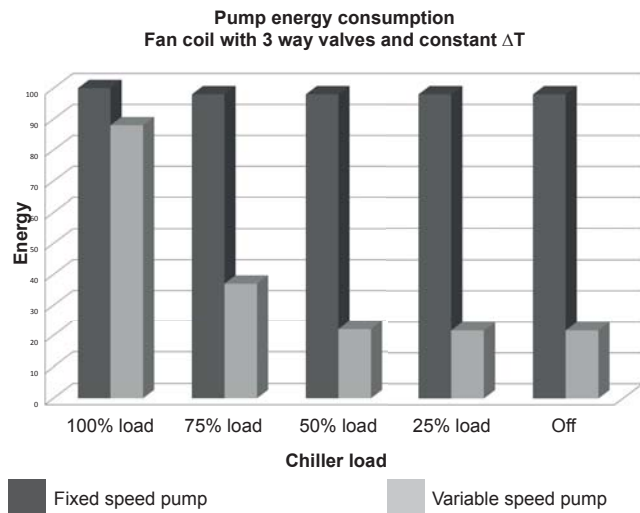

PUMP AFFINITY LAWS

“The power required for pumps varies as the cube of the flow rate.”

20% water flow reduction = 50% energy reduction.
40% water flow reduction = 80% energy reduction.

eDrive™ VARIABLE WATER FLOW MAY SAVE MONEY IN THE SYSTEM DESIGN COST

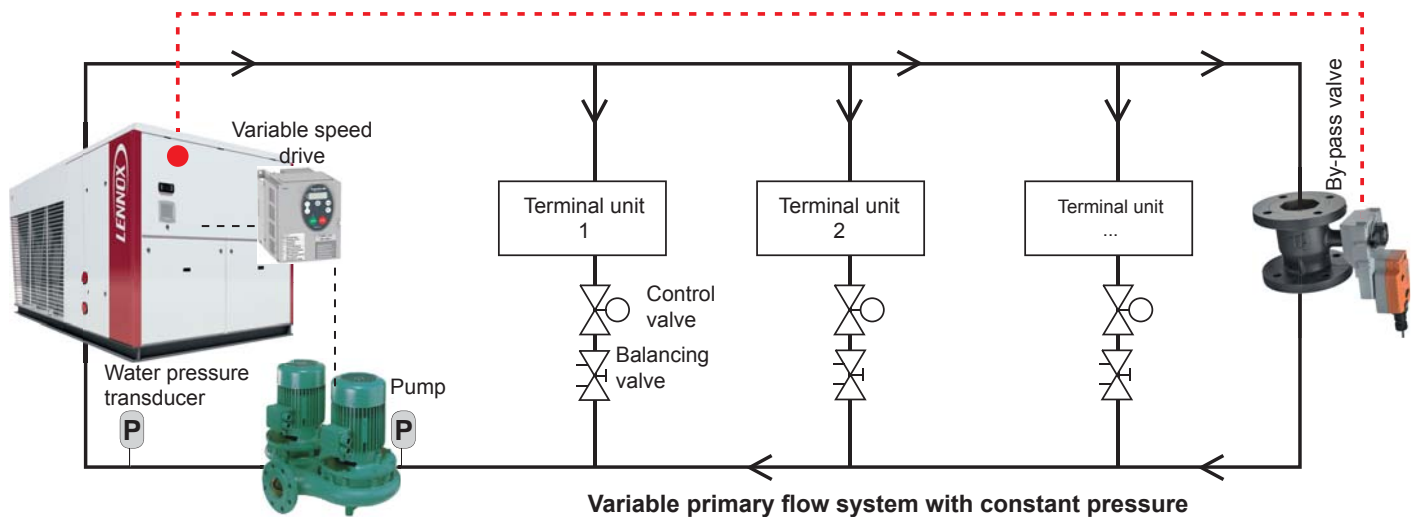

A variable primary flow design uses fewer components than primary–secondary systems as the pumps of the secondary distribution loop and the mixing tank are eliminated.

When compared with constant primary flow systems, terminal units can be equipped with two-way control valves instead of three-way valves often used in constant volume systems. Using two-way valves instead of three-way valves on fan coils represent a budget reduction that pays for the variable frequency driver cost. On top of that, the water flow set valve is eliminated as the pump adjustment to real installation needs can be done electronically. These factors may reduce the initial cost of the chilled water system.

eDrive™ VARIABLE WATER FLOW BY LENNOX

3 control modes available :

Constant speed

- Interest to set the right installation design flow (avoid setting valve).

Constant Delta P (setting to declare the required working pressure)

- Implementation and management adapted to systems with two-way valves and bypass of the installation to ensure a minimum water flow back into the evaporator.

Constant Delta T (Setting to declare the required delta T)

- Need a good installation with well balanced circuits to ensure good flow distribution when the flow is reduced.
- Installation with terminal units fitted with 3-way valves.

Operation for each mode:

- Constant speed : eDrive pilots the pump to the water flow desired when the compressors are in operation. When the compressors are stopped (dead zone), control will automatically reduce the speed of the pump to the minimum water flow. This minimum flow is also adjustable within minimum 30Hz (60% flow).
- Constant delta P : the eDrive™ regulation is managing the pump to maintain the required delta P in order to keep constant the customer available static pressure. When the terminals control valves close in response to decreased building loads, the pump controller slows the pump speed to maintain the target delta P. In this mode the pump does not detect terminal capacity reduction (fan speed staging)
- Constant Delta T : the eDrive™ regulation is managing the pump to maintain the required Delta T. When the Delta T is increasing in response to the number of compressors running, the pump controller increases the speed of the pump. Conversely, when the compressors are stopping in response to decreased building loads, the pump controller slows the pump speed to maintain the target Delta T.

Safety parameters:

- If the evaporating pressure reaches the low limit (risk of evaporator frosting), the flow is increased.
- If the outlet evaporator temperature reaches the low limit, the flow is set to the maximum.
- When the pump speed varies and the flow switch trips, the flow is automatically increased.
- During defrost procedure (HP), the flow is set to the maximum.
- Pump motor supply range from 30 Hz minimum to 50Hz maximum. Minimum pump motor frequency set at 30 Hz. Below this value, risk of pump motor failure due to overheat.
- For safe operation of the chiller, the unit is protected by the flow switch.
- Minimum and maximum admissible water flow per unit size: with constant delta T, the flow may vary from 60% to 100% of the selected pump nominal flow.
- Maximum change in flow rate through the evaporator: a 10% per minute change in flow rate is admissible in most of air conditioning applications.

Installation instructions to respect in case of variable primary flow:

- The hydraulic system will have to be properly designed and balanced to ensure a right water flow distribution through the chiller evaporator and the terminal units.
- The hydraulic system will have to be properly designed to respect minimum and maximum water flow through each chiller following the values given by the manufacturer.

Case of constant Delta P mode :

- In case of system designed with terminal units equipped with 2 way valves, the hydraulic system will need to have a bypass flow to ensure a minimum water flow through the chiller evaporator.

Méthode de by-pass :

- Bypass adequate water flow can be achieved with a slow modulating opening as soon as the water flow rate is near the minimum. When the water flow rises according to predefined setting, this valve closes. This bypass modulating valve provided by LENNOX (contact customer service) is controlled by our Climatic control. The bypass should be positioned at the beginning of the installation near the unit and allows significant energy savings and cost as opposed to a location at the end of the system.
 - An alternative is to install some 3-way valves at different points of the terminal units. This approach allows constant minimum flow in the chiller or heat pump and ensures a cheaper system.
-
- The minimum water flow through the chiller evaporator will need to respect a minimum value that is 60% of the nominal chiller water flow.
 - The flow bypass from chilled water supply to chilled water return can be done with a motorized bypass valve opened via a signal from a flow meter.
 - For safe operation some terminals can be equipped with three way control valves in order to ensure the flow will not drop below the minimum value at any load condition.
 - The water flow must not vary by more than 10% per minute. If the flow rate changes more rapidly, the system should contain a minimum of 6,5 liters of water per kW instead of 3 liters/kW.
 - Check the control valve authority in low load periods, especially in case of long pipe hydraulic systems.

Compared with the basic configuration, this option features an additional refrigerant/water heat exchanger on the compressor discharge line, allowing recovery of 15% of the rejected heat. This heat exchanger is large enough to recover heat for the production of free hot water simultaneously with chilled water production. The heating capacity of the heat recovery circuit is approximately equal to the power input of the compressor. Typical heat recovery applications can be facilities with high domestic hot water usage, such as health care, hotels, etc.

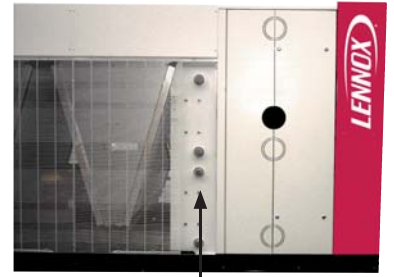

Partial heat recovery

Notes:

This option is available on cooling only and heat-pump versions. Heat recovery can only occur when the unit is running either in cooling or heating mode.

Partial heat recovery

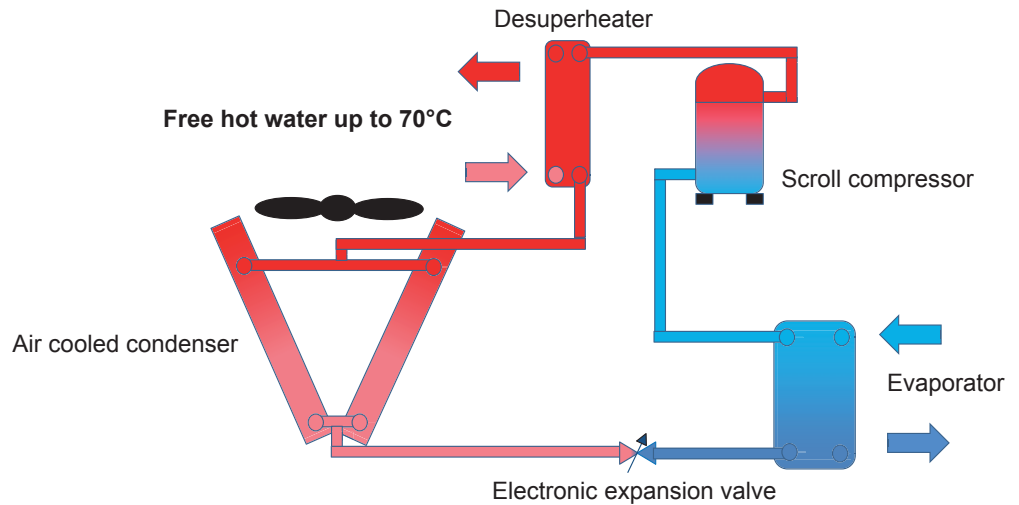

	Water in/out: 50/55 °C			Water in/out: 55/60 °C			Water in/out: 50/60 °C		
	Recovery (kW)	Wf (m ³ /h)	Dp (kPa)	Recovery (kW)	Wf (m ³ /h)	Dp (kPa)	Recovery (kW)	Wf (m ³ /h)	Dp (kPa)
NAC/NAH 200	41	7,18	6,00	32	5,62	4	37	3,26	2
NAC/NAH 230	52	9,11	9,00	43	7,55	6	48	4,22	2
NAC/NAH 270	56	9,81	7,00	44	7,73	5	50	4,40	2
NAC/NAH 300	65	11,39	9,17	52	9,13	6	59	5,19	2
NAC 340	79	13,84	9,80	64	11,24	6	72	6,34	2
NAC 380	101	17,69	14,28	83	14,58	10	93	8,18	3
NAC 420	91	15,94	9,17	73	12,82	6	82	7,22	2
NAC 480	106	18,57	12,00	86	15,11	8	96	8,45	3
NAC 540	143	25,05	15,00	118	20,73	11	129	11,35	4
NAC 600	150	26,28	13,00	122	21,43	9	136	11,97	3
NAC 640	154	27,07	13,33	125	22,07	9	139	12,33	3

Wf :
Water flow in m³ per hour

Dp :
Water pressure drop in KPa

Heat recovery is one of our solutions to decrease and offset energy bills continually on the rise.

NEOSYS with Heat Recovery option operate as a standard chiller as long as heat is not required or simultaneously produce chilled and hot water which can be used for applications like preheating of a boiler, heating or domestic hot water.

Heating or preheating in series with a boiler, the heat recovery option enables to reduce :

- Purchase and installation cost : boiler is undersized.
- Operating cost : free hot water when unit produce chilled water.

In series with an auxiliary heater , this option can also replace the heater in low temperature heating systems.

A heat recovery chiller is suitable for all industrial process requiring both chilled and hot water.

The LENNOX total heat recovery system on NEOSYS :

- Parallel assembly, stainless steel brazed plate heat exchanger mounted in parallel to the air condensers maintain maximum performance and efficiency whatever the conditions : 100% heat recovery in opposite of series assembly.
- Free hot water from 25 to 55°C
- Very Low refrigerant charge, no additional refrigerant charge thanks to braze plate heat exchanger.
- High Total Energy Ratio values : TER (*)
- Standard Features factory mounted and tested:
 - Stainless steel heat exchanger with control
 - Paddle water flow switch
 - Temperature hydraulic sensors
 - Victaulic coupling
 - 3 way valve (0-10V) for cold start
 - On/Off pump control
 - Antifreeze protection + insulation (in option)

(*) TER: Total Efficiency Ratio is the total energy efficiency of the units when there is a production of chilled water and hot water simultaneously. Cold water and hot water are valued to the total power consumption of the unit: $TER = (\text{cooling capacity} + \text{recovered heating capacity}) / \text{total power consumption}$.

Control principle:

The unit switches to recovery mode using a dry contact supplied by the user and connected to the CLIMATIC. CLIMATIC controller regulates the water leaving temperature of the recovery exchanger using temperature probes included at inlet and outlet of the exchanger. It offers the possibility of programming schedule one or more setpoints.

Recovery capacity is entirely dependent of the cooling needs. The capacity step is important due to two independent refrigerant circuits and varies depending on the number of compressor ;

Unit with 4 compressors

Cooling capacity step	Heat recovery step
27%	27%
53%	27% or 53%
73%	53% or 73%
100%	53% or 100%

Unit with 6 compressors

Cooling capacity step	Heat recovery step
17%	17%
33%	17% or 33%
50%	33% or 50%
67%	33% or 67%
83%	67% or 83%
100%	50% or 100%

CLIMATIC provides a dry contact to control the on/off of the pump(s). It also delivers a 0 -10V signal to control a 3-way valve to avoid cold start if the inlet water temperature is too low ensuring the correct operation of the unit. The use of a 3-way valve can be avoided by using a variable speed pump. This solution allows for greater control of the output temperature of water and thus to reduce the power consumption of the pump.

Protection against lack of water flow is provided by a paddle flow switch included in the option.

Total heat recovery : 100%

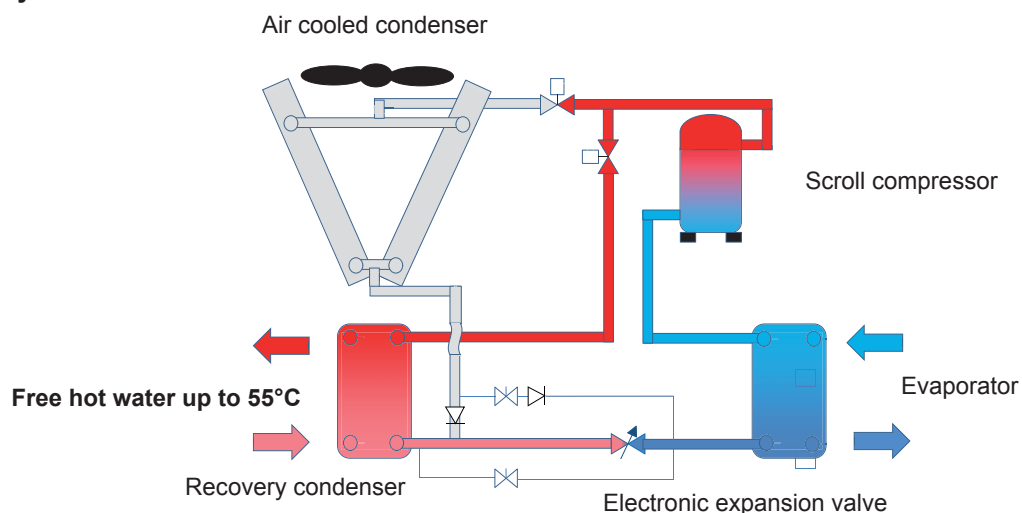

Operating limits		
Maxi. outlet water temperature	°C	5
Mini. outlet water temperature		20
Min. difference water inlet/outlet		3
Max. difference water inlet/outlet		8
Mini. water temperature at start-up		46

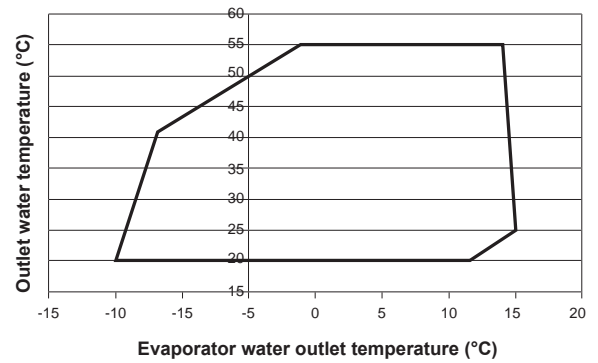

		NAC	200	230	270	300	340	380	420	480	540	600	640
WATER IN/OUT = 35/40°C	Cooling capacity in recovery mode	kW	214,1	253,9	300,2	318,9	374,5	431,8	455,1	521,4	586,8	657,7	664
	Absorbed power in recovery mode	kW	64,1	73,9	92,3	94,2	109,9	125,4	135,6	149,6	172,2	197,2	197,8
	Recovered heating capacity	kW	264,3	311,4	372,9	392,4	460,2	529,3	561,1	637,5	721,1	812,1	818,7
	EER in heat recovery mode		3,34	3,44	3,25	3,39	3,41	3,44	3,36	3,49	3,41	3,34	3,36
	COP in heat recovery mode		4,12	4,21	4,04	4,17	4,19	4,22	4,14	4,26	4,19	4,12	4,14
	Total efficiency ratio = (CC+HC)/PI		7,46	7,65	7,29	7,55	7,60	7,66	7,49	7,75	7,60	7,45	7,50
	Water flow	m ³ /h	45,6	53,7	64,3	67,7	79,4	91,3	96,8	110	124,4	140,1	141,2
	Exchanger pressure drop	kPa	53	49	69	43	58	57	63	61	72	89	91
WATER IN/OUT = 40/45°C	Cooling capacity in recovery mode	kW	201,3	239,3	282,2	301,6	352	406,5	428,4	491	553,4	619,5	624,6
	Absorbed power in recovery mode	kW	70,3	81,3	101,2	103,6	120,7	137,9	148,9	164,5	188,5	214,5	214,9
	Recovered heating capacity	kW	258,1	304,5	364,2	385	449	517,2	548,5	622,7	704,7	792,4	797,6
	EER in heat recovery mode		2,86	2,94	2,79	2,91	2,92	2,95	2,88	2,98	2,94	2,89	2,91
	COP in heat recovery mode		3,67	3,75	3,60	3,72	3,72	3,75	3,68	3,79	3,74	3,69	3,71
	Total efficiency ratio = (CC+HC)/PI		6,53	6,69	6,39	6,63	6,64	6,70	6,56	6,77	6,67	6,58	6,62
	Water flow	m ³ /h	44,5	52,5	62,8	66,4	77,4	89,2	94,6	107,4	121,6	136,7	137,6
	Exchanger pressure drop	kPa	51	47	66	41	55	54	61	58	69	85	86
WATER IN/OUT = 45/55°C	Cooling capacity in recovery mode	kW	178,9	210,1	253,1	266,9	313,1	359,5	381,2	430,7	488,5	552,6	556,6
	Absorbed power in recovery mode	kW	80	94,4	113,3	120,9	137,6	158,9	169,3	191,1	214,6	238,2	238,5
	Recovered heating capacity	kW	245,9	289,3	348,1	368,4	428,2	492,5	523	590,7	667,9	751,4	755,3
	EER in heat recovery mode		2,24	2,23	2,23	2,21	2,28	2,26	2,25	2,25	2,28	2,32	2,33
	COP in heat recovery mode		3,07	3,06	3,07	3,05	3,11	3,10	3,09	3,09	3,11	3,15	3,17
	Total efficiency ratio = (CC+HC)/PI		5,31	5,29	5,31	5,25	5,39	5,36	5,34	5,34	5,39	5,47	5,50
	Water flow	m ³ /h	21,2	23,9	23,9	31,8	34,7	42,5	45,1	50,9	57,6	64,8	65,1
	Exchanger pressure drop	kPa	13	12	17	11	14	14	15	14	18	22	22
Exchanger volume	dm ³	15,8	23,9	23,9	34,7	34,7	42,8	42,8	56,2	60,3	60,3	60,3	
Exchanger connection diameters		4"/4"	4"/4"	4"/4"	5"/5"	5"/5"	6"/6"	6"/6"	6"/6"	6"/6"	6"/6"	6"/6"	

Compared with the basic configuration this option features one or two additional V free cooling coils at the back of the unit. The free cooling includes two motorised valves, allowing the chilled water to run through the free-cooling coils, which uses less power and utilises the lower ambient air to cool the water. The cooling capacity of one V free cooling coil at 0°C ambient is approximately 100 kW. NEOSYS free cooling system is using the same fans and speed inverters as for the standard unit in order to keep the same acoustic capabilities. The hydraulic module options are compatible with the Free Cooling option but glycol is of course required.

Typical free cooling applications can be facilities with cooling demand all along the year, such as offices with high internal loads like computer rooms, data centers, etc. In the North and North-East part of Europe, the ambient temperature is below 5°C between 20 and 45% of the year that makes this option very attractive.

Control principle

The control principle is the following: if ambient Temperature < return Temperature – 3°C, motorised valves open to by-pass return water flow through the Free Cooling coils. The Free Cooling fans are driven by the CLIMATIC 60 via a specific PID algorithm. The Free cooling operation is considered as a cooling stage that has a priority on the compressor stages: only if the free cooling fan speed has reached the maximum fan speed then the compressors are allowed to run with their own PID.

Advantages of the NEOSYS free cooling system

- Simultaneous compressor cooling capability to reach building needs in any conditions (vs. DX free cooling that can not operate simultaneous compressor and free cooling).
- Design with additional V free cooling coils to eliminate unnecessary air pressure drop when running 100% in compressor cooling mode thus reducing all along the year energy fan consumption (vs. traditional free cooling system with free cooling coils located in series with the condensing coil.)
- Free cooling as soon as the air outside is cold enough (3°C below return water temperature).
- Reduce the running use of the compressors.
- Extend the life expectancy of the compressors.
- EER up to 63 (Water 15/10°C, Air -15°C).
- Reduce power costs.
- Payback could be as little as 12 months

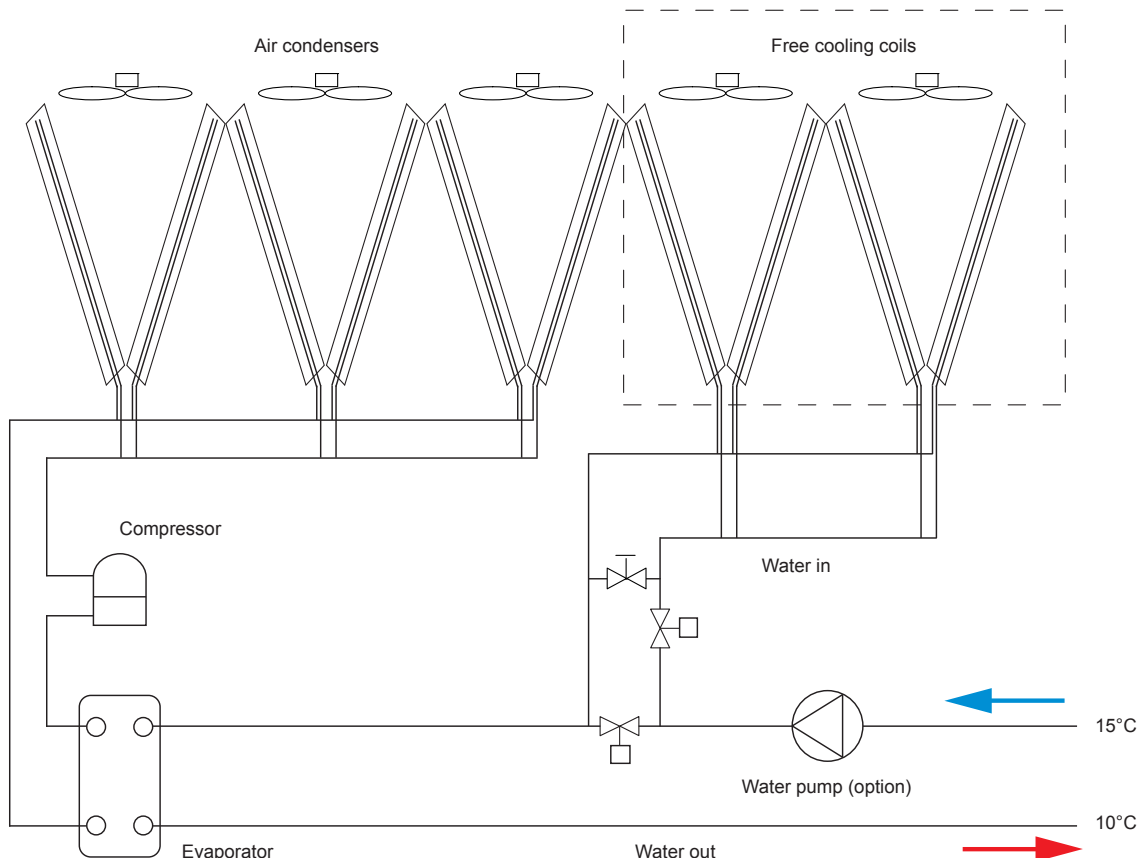

Example of free cooling:

Unit running 100% in free cooling mode:

Return water temperature: 12°C (30% glycol)

Number of "V"		1V for NAC 200 to 540					2V for NAC 200 to 540				
Air flow	m ³ /h	38000					76000				
Water flow	m ³ /h	36					72				
Ambient temperature	°C	-15	-10	-5	0	5	-15	-10	-5	0	5
Outlet temperature	°C	6,7	7,7	8,7	9,7	10,7	6,7	7,7	8,7	9,7	10,7
Free cooling capacity	kW	190	153	117	82	47	380	306	234	164	94
Free cooling absorbed power	kW	3,2	3,2	3,2	3,2	3,2	6,4	6,4	6,4	6,4	6,4
EER		59	48	37	26	15	59	48	37	26	15
Free cooling pressure drop to be added to evaporator pressure drop	kPa	57					62				

Return water temperature: 15°C (30% glycol)

Number of "V"		1V for NAC 200 to 540					2V for NAC 200 to 540				
Air flow	m ³ /h	38000					76000				
Water flow	m ³ /h	36					72				
Ambient temperature	°C	-15	-10	-5	0	5	-15	-10	-5	0	5
Outlet temperature	°C	9	10,1	11,1	12,1	13,1	9	10,1	11,1	12,1	13,1
Free cooling capacity	kW	214	177	140	104	69	428	354	280	208	138
Free cooling absorbed power	kW	3,2	3,2	3,2	3,2	3,2	6,4	6,4	6,4	6,4	6,4
EER		67	55	44	33	22	67	55	44	33	22
Free cooling pressure drop to be added to evaporator pressure drop	kPa	57					62				

IMPORTANT NOTE : Thanks to variable speed fans, maximum sound level can be reduced.
 NEOSYS maximum air flow can be adjusted between 70 % and 100 % of the nominal airflow to meet maximum sound level requirements.

NAC

Please contact LENNOX for noise level calculations at reduced airflow.

Spectrum per octave band dB(A)								Maximum global sound power	Maximum sound pressure at 10 meters envelopping surface
NAC	125 Hz	250 Hz	500 Hz	1000 Hz	2000 Hz	4000 Hz	8000 Hz	EUROVENT Lw dB(A)	(1) Lp dB(A)
200	68	79	83	85	82	75	68	89	58
230	68	80	84	85	82	76	68	89	58
270	68	80	84	85	83	76	68	89	58
300	70	82	85	87	84	78	70	91	60
340	70	82	85	87	84	78	70	91	60
380	70	82	86	87	84	78	70	91	60
420	71	83	87	88	85	79	71	92	61
480	71	83	87	88	86	79	71	92	61
540	71	83	87	89	87	80	71	93	62
600	72	83	88	90	88	81	72	94	63
640	72	83	88	90	88	81	72	94	63
680	73	85	88	90	87	81	73	94	63
760	73	85	89	90	88	81	73	94	63
840	74	86	90	91	88	82	74	95	64
960	74	86	90	91	89	82	74	95	64
1080	74	86	90	92	90	83	74	96	65

NAH

Spectrum per octave band dB(A)								Maximum global sound power	Maximum sound pressure at 10 meters envelopping surface
NAH	125 Hz	250 Hz	500 Hz	1000 Hz	2000 Hz	4000 Hz	8000 Hz	EUROVENT Lw dB(A)	(1) Lp dB(A)
200	68	79	83	85	82	75	68	89	58
230	68	80	84	85	82	76	68	89	58
270	70	82	85	87	84	78	70	91	60
300	70	82	85	87	84	78	70	91	60
340	70	82	85	87	84	78	70	91	60
380	71	83	87	88	85	79	71	92	61
420	71	83	87	88	85	79	71	92	61
480	71	83	87	88	86	79	71	92	61

(1) : For information only: Data calculated by envelopping surface method in free open field.

Enveloping Surface

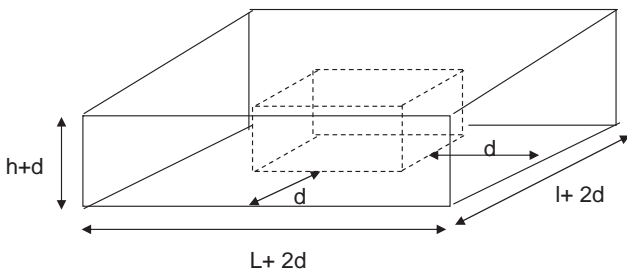

$$A = 2(L+2d)(h+d) + 2(l+2d)(h+d) + (L+2d)(l+2d)$$

NAC

NAC		200 > 340	380	420 - 480	540	600 > 680	760	840 - 960	1080
Min. outlet water temperature	°C	5							
Min. outlet water temperature with brine operation option	°C	- 10							
Max. inlet water temperature	°C	20							
Min. difference water inlet/outlet	°C	3							
Max. difference water inlet/outlet	°C	8							
Min. outside air temperature	°C	6							
Min. outside air temperature Winter operation option	°C	- 20							
Maximum outside air temperature : Full capacity operation	°C	46	43	46	43	46	43	46	43

NAH

Cooling mode	NAH	200 > 480
Min. outlet water temperature	°C	5
Max. inlet water temperature	°C	20
Min. difference water inlet/outlet	°C	3
Max. difference water inlet/outlet	°C	8
Min. outside air temperature	°C	6
Maximum outside air temperature : Full capacity operation	°C	46

Heating mode	NAH	200 > 480
Min. condenser outlet water temperature	°C	24
Max. condenser outlet water temperature	°C	50
Min. difference water inlet/outlet	°C	3
Max. difference water inlet/outlet	°C	8
Min. outside air temperature (Water outlet temp. : 37°C)	°C	- 12
Max. outside air temperature	°C	30

NAC
Operating envelope
Cooling mode

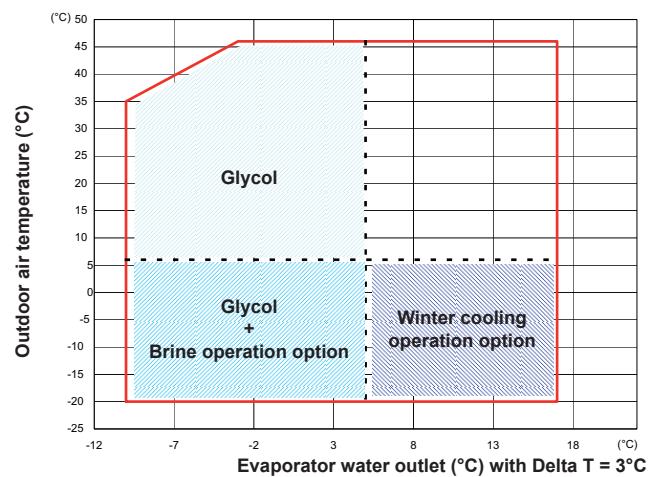

Maximum outdoor air temperature = 43°C on NAC 380 / NAC 540 and NAC 1080

NAH
Operating envelope
Cooling mode

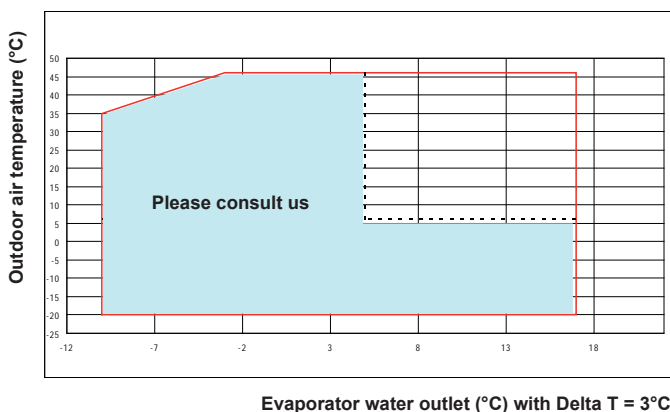

NAH
Operating envelope
Heating mode

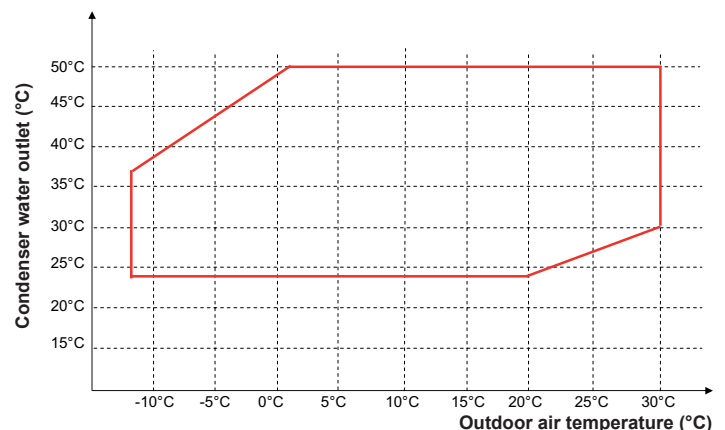

UNITS
NAC

NEOSYS		200	230	270	300	340	380	420	480	540	600	640
Minimum and maximum voltage	V	380 V / 420 V										
Maximum power	kW	96,7	113,7	135,0	147,1	166,2	191,7	205,9	231,4	258,1	288,4	288,4
Maximum current	A	166,5	195,8	225,0	247,3	277,2	321,3	344,1	388,2	431,7	482,8	482,8
Maximum current (with cos phi 0,95 option)	A	152,6	162,7	191,9	211,2	237,3	272,3	294,4	329,4	366,0	410,2	410,2
Start-up intensity	A	393,9	446,5	475,7	498,0	527,9	572,0	594,8	638,9	765,9	817,0	817,0
Start-up intensity (with cos phi 0,95 option)	A	382,6	423,2	452,4	471,7	497,8	523,8	554,9	589,9	712,3	756,5	756,5
Start-up intensity (with softstarter option)	A	255,7	314,4	343,6	365,9	395,8	439,9	462,7	506,8	579,3	630,4	630,4
Start-up intensity (with softstarter and cos phi 0,95 options)	A	236,4	261,7	290,9	310,2	336,3	371,3	393,4	428,4	489,4	533,6	533,6
Maximum connectable power section	mm ²	185	185	185	300	300	300	300	300	300	300	300

UNITS (dual connection point - as Standard)

NEOSYS		680	760	840	960	1080
Minimum and maximum voltage	V	380 V / 420 V				
Maximum power per box	kW	166,2	191,7	205,9	231,4	258,1
Maximum current per box	A	277,2	321,3	344,1	388,2	431,7
Maximum current per box (with cos phi 0,95 option)	A	237,3	272,3	294,4	329,4	366,0
Start-up intensity per box	A	527,9	572,0	594,8	638,9	765,9
Start-up intensity per box (with cos phi 0,95 option)	A	497,8	523,8	554,9	589,9	712,3
Start-up intensity per box (with softstarter option)	A	395,8	439,9	462,7	506,8	579,3
Start-up intensity per box (with softstarter and cos phi 0,95 options)	A	336,3	371,3	393,4	428,4	489,4
Maximum connectable power section	mm ²	2 x 300				

UNITS (single main power connection as an option)

NEOSYS		680	760	840	960	1080
Minimum and maximum voltage	V	380 V / 420 V				
Maximum power	kW	332,4	383,4	411,8	462,8	516,2
Maximum current	A	554,5	642,6	688,3	776,4	863,4
Maximum current (with cos phi 0,95 option)	A	474,7	544,6	588,9	658,8	732,0
Start-up intensity	A	805,2	893,3	939,0	1027,1	1197,6
Start-up intensity (with cos phi 0,95 option)	A	735,2	796,1	849,4	919,3	1078,3
Start-up intensity (with softstarter option)	A	673,1	761,2	806,9	895,0	1011,0
Start-up intensity (with softstarter and cos phi 0,95 options)	A	573,7	643,6	687,9	757,8	855,4
Maximum connectable power section	mm ²					

OPTIONS

NEOSYS			200	230	270	300	340	380	420	480	540	600	640
Low pressure	Single pump Double pump	kW	2,20	3,00	3,00	4,00	4,00	5,50	5,50	5,50	7,50	7,50	7,50
	Single pump - Double pump Maximum current	A	5,00	6,00	6,00	8,05	8,05	10,50	10,50	10,50	13,80	13,80	13,80
High pressure	Single pump Double pump	kW	4,00	5,50	5,50	7,50	7,50	7,50	7,50	7,50	11,0	11,0	11,0
	Single pump - Double pump Maximum current	A	8,05	10,50	10,50	14,30	14,30	14,30	14,30	14,30	21,7	21,7	21,7
Evaporator anti-freeze heater *		kW	0,13										
Evaporator anti-freeze heater Maximum current		A	0,32										
Hydraulic anti-freeze heater		kW	0,23	0,23	0,23	0,23	0,24	0,24	0,24	0,24	0,24	0,24	0,24
Hydraulic anti-freeze heater Maximum current		A	0,56	0,56	0,56	0,56	0,60	0,60	0,60	0,60	0,60	0,60	0,60

* : Value x 2 if desuperheater

OPTIONS (dual connection point - as standard)

NEOSYS		680	760	840	960	1080
Evaporator anti-freeze heater power per box	kW	0,13				
Evaporator anti-freeze heater Maximum current per box	A	0,32				
Hydraulic anti-freeze heater power per box	kW	0,48				
Hydraulic anti-freeze heater Maximum current per box	A	1,20				

OPTIONS (single main power connection as an option)

NEOSYS		680	760	840	960	1080
Evaporator anti-freeze heater power	kW	0,26				
Evaporator anti-freeze heater Maximum current	A	0,65				
Hydraulic anti-freeze heater power	kW	0,96				
Hydraulic anti-freeze heater Maximum current	A	2,40				

UNITS
NAH

NEOSYS		200	230	270	300	340	380	420	480
Minimum and maximum voltage	V	380 V / 420 V							
Maximum power	kW	96,7	113,7	138,6	155,6	166,2	195,3	205,9	231,4
Maximum current	A	166,5	195,8	232,6	262,0	277,2	328,9	344,1	388,2
Maximum current (with cos phi 0,95 option)	A	152,6	178,4	218,4	244,2	260,3	306,6	322,8	361,5
Start-up intensity	A	393,9	446,5	483,3	512,7	527,9	579,6	594,8	638,9
Start-up intensity (with cos phi 0,95 option)	A	236,4	288,1	328,1	353,9	370,0	416,3	432,4	471,2
Start-up intensity (with sofstarter option)	A	255,7	314,4	351,2	380,6	395,8	447,5	462,7	517,0
Maximum connectable power section	mm ²	185	185	185	300	300	300	300	300

OPTIONS

NEOSYS		200	230	270	300	340	380	420	480	
Low pressure	Single pump Double pump	kW	2,20	3,00	3,00	4,00	4,00	5,50	5,50	5,50
	Single pump - Double pump Maximum current	A	5,00	6,00	6,00	8,05	8,05	10,50	10,50	10,50
High pressure	Single pump Double pump	kW	4,00	5,50	5,50	7,50	7,50	7,50	7,50	7,50
	Single pump - Double pump Maximum current	A	8,05	10,50	10,50	14,30	14,30	14,30	14,30	14,30
Evaporator anti-freeze heater *		kW	0,32	0,32	0,13	0,32	0,32	0,32	0,32	0,32
Evaporator anti-freeze heater Maximum current		A	0,81	0,81	0,32	0,81	0,81	0,81	0,81	0,81
Hydraulic anti-freeze heater		kW	0,23	0,23	0,23	0,23	0,24	0,24	0,24	0,24
Hydraulic anti-freeze heater Maximum current		A	0,56	0,56	0,56	0,56	0,60	0,60	0,60	0,60

* : Value x 2 if desuperheater

COOLING CAPACITIES

NAC		Outdoor air temperature												
		44				45				46				
		Pf	Pe	Wf	Dp	Pf	Pe	Wf	Dp	Pf	Pe	Wf	Dp	
		kW	kW	m³/h	kPa	kW	kW	m³/h	kPa	kW	kW	m³/h	kPa	
5 °C	200	172,3	83,4	29,6	30,3	169,5	84,9	29,2	29,4	166,6	86,5	28,7	28,5	
	230	194,8	100,0	33,5	38,0	191,5	101,9	32,9	36,8	188,2	103,9	32,4	35,7	
	270	224,4	124,4	38,6	38,8	220,4	126,9	37,9	37,5	216,4	129,4	37,2	36,2	
	300	255,2	124,7	43,9	34,2	251,2	127,1	43,2	33,2	247,1	129,6	42,5	32,2	
	340	290,0	146,1	49,9	24,3	285,1	148,9	49,1	23,6	280,2	151,7	48,2	22,8	
	380	319,0	174,7	54,9	29,0	264,3	138,1	45,5	N/A	259,6	141,0	44,7	N/A	
	420	356,1	177,6	61,3	35,6	350,3	181,0	60,3	34,5	344,5	184,6	59,3	33,4	
	480	410,7	204,4	70,7	35,1	404,5	208,5	69,6	34,1	398,1	212,8	68,5	33,1	
	540	444,0	239,1	76,4	40,6	436,9	244,5	75,2	39,4	363,3	197,7	62,5	N/A	
	600	508,1	259,6	87,4	42,4	500,2	265,4	86,0	41,2	492,0	271,5	84,6	39,9	
	640	526,0	268,0	90,5	41,9	517,7	274,0	89,1	40,7	509,2	280,3	87,6	39,4	
	680	580,0	292,1	99,8	30,2	570,3	297,7	98,1	29,2	560,4	303,5	96,4	28,3	
	760	638,1	349,5	109,8	36,1	528,7	276,3	91,0	N/A	519,3	282,1	89,3	N/A	
	840	712,1	355,2	122,5	45,8	700,6	362,1	120,5	44,4	688,9	369,2	118,5	43,0	
	960	821,4	408,7	141,3	47,7	808,9	417,0	139,2	46,3	796,2	425,5	137,0	45,0	
	1080	888,1	478,2	152,8	55,3	873,7	488,9	150,3	53,6	726,5	395,3	125,0	N/A	
	6 °C	200	177,6	83,9	30,6	32,0	174,7	85,4	30,1	31,1	171,8	86,9	29,5	30,1
		230	200,7	100,6	34,5	40,2	197,3	102,6	33,9	38,9	193,9	104,6	33,4	37,7
270		231,0	125,3	39,7	40,9	226,9	127,8	39,0	39,6	222,7	130,4	38,3	38,2	
300		263,2	125,4	45,3	36,2	259,0	127,8	44,6	35,1	254,8	130,3	43,8	34,1	
340		298,8	147,0	51,4	25,7	293,8	149,8	50,5	24,9	288,7	152,7	49,7	24,1	
380		328,5	176,0	56,5	30,6	272,4	139,0	46,9	N/A	267,6	141,9	46,0	N/A	
420		367,0	178,7	63,1	37,6	361,1	182,1	62,1	36,5	355,1	185,7	61,1	35,4	
480		422,8	205,7	72,7	37,1	416,4	209,9	71,6	36,0	409,8	214,2	70,5	35,0	
540		456,7	241,2	78,6	42,8	449,3	246,6	77,3	41,5	374,2	198,9	64,4	N/A	
600		522,8	261,7	90,0	44,8	514,7	267,6	88,6	43,5	506,4	273,8	87,1	42,2	
640		541,3	270,2	93,1	44,2	532,8	276,3	91,7	42,9	524,2	282,7	90,2	41,6	
680		597,6	294,0	102,8	31,9	587,6	299,6	101,1	30,9	577,4	305,4	99,3	29,9	
760		657,0	352,1	113,0	38,1	544,8	278,0	93,7	N/A	535,1	283,8	92,1	N/A	
840		734,0	357,3	126,3	48,5	722,2	364,3	124,2	47,0	710,2	371,4	122,2	45,6	
960		845,6	411,5	145,5	50,4	832,7	419,8	143,3	48,9	819,7	428,4	141,0	47,5	
1080		913,4	482,4	157,1	58,3	898,6	493,2	154,6	56,5	748,5	397,8	128,8	N/A	
7 °C		200	183,0	84,4	31,5	33,9	180,0	85,9	31,0	32,8	177,0	87,4	30,4	31,8
		230	206,7	101,3	35,6	42,4	203,2	103,2	35,0	41,1	199,7	105,3	34,4	39,8
	270	237,6	126,3	40,9	43,1	233,4	128,8	40,2	41,7	147,7	69,1	25,4	N/A	
	300	271,2	126,2	46,7	38,2	266,9	128,6	45,9	37,1	262,6	131,1	45,2	36,0	
	340	307,7	148,0	52,9	27,1	302,6	150,8	52,1	26,3	297,4	153,7	51,2	25,5	
	380	285,6	137,1	49,1	N/A	280,6	139,9	48,3	N/A	275,6	142,8	47,4	N/A	
	420	378,1	179,8	65,1	39,7	372,0	183,3	64,0	38,6	365,9	186,8	62,9	37,4	
	480	434,9	207,2	74,8	39,1	428,3	211,3	73,7	38,0	421,6	215,6	72,5	36,9	
	540	469,3	243,3	80,7	45,1	280,6	139,9	48,3	N/A	385,3	200,1	66,3	N/A	
	600	537,5	263,9	92,5	47,2	529,2	269,9	91,0	45,8	520,7	276,1	89,6	44,5	
	640	556,5	272,4	95,7	46,6	547,9	278,6	94,3	45,3	539,1	285,1	92,7	43,9	
	680	615,5	296,0	105,9	33,7	605,2	301,6	104,1	32,7	594,7	307,4	102,3	31,6	
	760	571,1	274,2	98,3	N/A	561,2	279,8	96,6	N/A	551,3	285,6	94,8	N/A	
	840	756,3	359,6	130,1	51,2	744,1	366,5	128,0	49,7	731,7	373,6	125,9	48,2	
	960	869,8	414,3	149,6	53,1	856,6	422,7	147,4	51,6	843,1	431,3	145,1	50,1	
	1080	938,6	486,7	161,5	61,3	784,6	392,3	135,0	N/A	770,6	400,2	132,6	N/A	

Performance data are available up to 52°C on request

Values in grey cells : derating capacity, compressor(s) unload due to high discharge temperature
 N/A : Pressure drop of derating capacity need to be calculated thanks to page 15

Pf :
 Net cooling capacity in kW

Pe :
 Effective absorbed power in cooling mode

Wf :
 Water flow in m³ per hour

Dp :
 Water pressure drop in KPa

COOLING CAPACITIES

NAC		Outdoor air temperature												
		44				45				46				
		Pf	Pe	Wf	Dp	Pf	Pe	Wf	Dp	Pf	Pe	Wf	Dp	
		kW	kW	m³/h	kPa	kW	kW	m³/h	kPa	kW	kW	m³/h	kPa	
Water outlet temperature	8 °C	200	188,5	84,9	32,4	35,8	185,4	86,4	31,9	34,7	182,3	88,0	31,4	33,6
		230	212,7	102,0	36,6	44,7	209,1	103,9	36,0	43,4	205,5	105,9	35,4	42,0
		270	244,3	127,3	42,0	45,5	240,0	129,8	41,3	44,0	152,3	69,5	26,2	N/A
		300	279,4	126,9	48,1	40,3	275,0	129,4	47,3	39,2	270,5	131,9	46,5	38,0
		340	316,8	149,0	54,5	28,6	311,5	151,8	53,6	27,8	306,1	154,7	52,7	26,9
		380	294,1	138,0	50,6	N/A	289,0	140,8	49,7	N/A	283,9	143,8	48,8	N/A
		420	389,4	180,9	67,0	42,0	383,1	184,4	65,9	40,7	376,8	188,0	64,8	39,5
		480	447,0	208,6	76,9	41,1	440,2	212,8	75,7	40,0	433,3	217,1	74,5	38,8
		540	481,8	245,5	82,9	47,3	403,6	197,4	69,4	N/A	396,5	201,3	68,2	N/A
		600	552,1	266,1	95,0	49,7	543,6	272,1	93,5	48,2	535,0	278,4	92,0	46,8
		640	571,7	274,7	98,4	49,1	562,9	281,0	96,8	47,6	553,9	287,5	95,3	46,2
		680	633,6	298,0	109,0	35,6	623,0	303,7	107,2	34,5	612,2	309,4	105,3	33,4
	760	588,1	276,0	101,2	N/A	578,0	281,7	99,4	N/A	567,7	287,5	97,7	N/A	
	840	778,8	361,9	134,0	54,1	766,3	368,8	131,8	52,5	753,6	375,9	129,6	50,9	
	960	893,9	417,2	153,8	56,0	880,3	425,6	151,5	54,4	866,6	434,2	149,1	52,8	
	1080	963,7	491,0	165,8	64,5	807,3	394,7	138,9	N/A	793,0	402,7	136,4	N/A	
	9 °C	200	194,0	85,4	33,4	37,7	190,9	86,9	32,8	36,6	187,7	88,5	32,3	35,5
		230	218,8	102,7	37,6	47,1	215,1	104,6	37,0	45,7	211,5	106,6	36,4	44,3
		270	251,1	128,3	43,2	47,9	246,7	130,8	42,4	46,3	157,0	69,9	27,0	N/A
		300	287,6	127,7	49,5	42,6	283,1	130,2	48,7	41,3	278,5	132,7	47,9	40,1
		340	326,0	150,0	56,1	30,2	320,5	152,9	55,1	29,3	315,0	155,8	54,2	28,3
		380	302,7	139,0	52,1	N/A	297,5	141,8	51,2	N/A	292,2	144,7	50,3	N/A
		420	400,8	182,1	69,0	44,3	394,4	185,6	67,9	43,0	387,9	189,2	66,7	41,7
		480	459,0	210,1	79,0	43,2	452,0	214,3	77,8	42,0	445,0	218,6	76,6	40,8
		540	422,3	194,8	72,7	N/A	415,1	198,6	71,4	N/A	407,8	202,6	70,2	N/A
		600	566,6	268,3	97,5	52,2	558,0	274,4	96,0	50,7	549,2	280,7	94,5	49,2
		640	586,8	277,0	101,0	51,5	577,8	283,3	99,4	50,1	568,7	289,9	97,8	48,6
		680	651,9	300,1	112,2	37,5	641,0	305,8	110,3	36,4	630,0	311,5	108,4	35,2
	760	605,4	278,0	104,2	N/A	595,0	283,6	102,4	N/A	584,4	289,4	100,5	N/A	
	840	801,6	364,2	137,9	57,1	788,8	371,2	135,7	55,4	775,7	378,3	133,5	53,7	
	960	918,0	420,2	157,9	58,8	904,1	428,6	155,5	57,2	890,0	437,3	153,1	55,5	
	1080	844,7	389,6	145,3	N/A	830,2	397,3	142,8	N/A	815,6	405,2	140,3	N/A	
	10 °C	200	199,6	85,9	34,3	39,8	196,4	87,4	33,8	38,6	193,1	89,0	33,2	37,4
		230	225,0	103,4	38,7	49,6	221,2	105,4	38,1	48,1	217,4	107,4	37,4	46,6
		270	258,0	129,3	44,4	50,3	164,5	69,0	28,3	N/A	161,8	70,3	27,8	N/A
		300	296,0	128,6	50,9	44,9	291,4	131,0	50,1	43,6	286,7	133,5	49,3	42,3
340		335,3	151,1	57,7	31,8	329,7	154,0	56,7	30,8	324,0	156,9	55,7	29,9	
380		311,5	140,0	53,6	N/A	306,1	142,8	52,7	N/A	300,7	145,7	51,7	N/A	
420		412,4	183,3	71,0	46,7	405,8	186,8	69,8	45,3	399,1	190,4	68,7	43,9	
480		471,0	211,6	81,0	45,4	463,9	215,9	79,8	44,1	456,7	220,2	78,6	42,8	
540		434,0	196,1	74,7	N/A	426,6	199,9	73,4	N/A	419,1	203,9	72,1	N/A	
600		581,1	270,5	100,0	54,7	572,3	276,6	98,5	53,2	563,4	283,0	96,9	51,6	
640		601,8	279,3	103,5	54,1	592,7	285,7	102,0	52,5	583,4	292,3	100,4	51,0	
680		670,5	302,2	115,4	39,6	659,4	307,9	113,4	38,3	648,0	313,7	111,5	37,1	
760	623,0	279,9	107,2	N/A	612,2	285,6	105,3	N/A	601,4	291,4	103,5	N/A		
840	824,8	366,7	141,9	60,3	811,6	373,6	139,6	58,5	798,2	380,8	137,3	56,7		
960	942,1	423,3	162,1	61,8	927,8	431,7	159,6	60,0	913,4	440,4	157,1	58,3		
1080	868,1	392,1	149,3	N/A	853,3	399,8	146,8	N/A	838,3	407,7	144,2	N/A		

Performance data are available up 52°C on request

 Values in grey cells : derating capacity, compressor(s) unload due to high discharge temperature
 N/A : Pressure drop of derating capacity need to be calculated thanks to page 15

Pf :
 Net cooling capacity in kW

Pe :
 Effective absorbed power in cooling mode

Wf :
 Water flow in m³ per hour

Dp :
 Water pressure drop in KPa

COOLING CAPACITIES

NAC		Outdoor air temperature												
		44				45				46				
		Pf	Pe	Wf	Dp	Pf	Pe	Wf	Dp	Pf	Pe	Wf	Dp	
		kW	kW	m³/h	kPa	kW	kW	m³/h	kPa	kW	kW	m³/h	kPa	
11 °C	200	205,4	86,4	35,3	41,9	202,0	88,0	34,8	40,7	198,7	89,5	34,2	39,4	
	230	231,2	104,1	39,8	52,2	227,4	106,1	39,1	50,6	223,5	108,1	38,4	49,0	
	270	264,9	130,4	45,6	52,9	169,5	69,4	29,2	N/A	166,7	70,8	28,7	N/A	
	300	304,6	129,4	52,4	47,3	299,8	131,9	51,6	45,9	294,9	134,4	50,7	44,6	
	340	344,7	152,2	59,3	33,5	339,0	155,1	58,3	32,5	333,2	158,0	57,3	31,4	
	380	320,4	141,0	55,1	N/A	314,9	143,8	54,2	N/A	309,3	146,7	53,2	N/A	
	420	424,1	184,6	73,0	49,2	417,4	188,1	71,8	47,7	410,5	191,7	70,6	46,3	
	480	483,1	213,2	83,1	47,6	475,8	217,5	81,9	46,2	468,4	221,8	80,6	44,9	
	540	445,8	197,4	76,7	N/A	438,2	201,2	75,4	N/A	430,5	205,2	74,1	N/A	
	600	595,5	272,7	102,5	57,3	586,6	278,9	100,9	55,7	577,5	285,4	99,4	54,1	
	640	616,8	281,6	106,1	56,7	607,5	288,0	104,5	55,1	598,1	294,7	102,9	53,4	
	680	689,4	304,4	118,6	41,7	677,9	310,1	116,6	40,4	666,3	315,9	114,6	39,1	
	760	640,8	282,0	110,2	N/A	629,7	287,6	108,3	N/A	618,6	293,5	106,4	N/A	
	840	848,3	369,2	145,9	63,5	834,7	376,2	143,6	61,6	821,0	383,3	141,3	59,8	
	960	966,1	426,4	166,2	64,8	951,5	434,9	163,7	62,9	936,7	443,6	161,2	61,1	
	1080	891,6	394,7	153,4	N/A	876,5	402,4	150,8	N/A	861,1	410,3	148,1	N/A	
	12 °C	200	211,2	87,0	36,3	44,1	207,7	88,5	35,7	42,8	204,3	90,1	35,1	41,5
		230	237,5	104,9	40,9	54,9	233,6	106,9	40,2	53,2	229,6	108,9	39,5	51,5
270		177,4	68,6	30,5	N/A	174,6	69,9	30,0	N/A	171,6	71,2	29,5	N/A	
300		313,2	130,3	53,9	49,7	308,3	132,8	53,0	48,3	303,3	135,3	52,2	46,9	
340		354,2	153,3	60,9	35,2	348,4	156,2	59,9	34,1	342,4	159,1	58,9	33,1	
380		329,4	142,1	56,7	N/A	323,7	144,9	55,7	N/A	318,0	147,8	54,7	N/A	
420		436,0	185,9	75,0	51,7	429,1	189,4	73,8	50,2	422,1	193,0	72,6	48,7	
480		495,1	214,8	85,2	49,8	487,6	219,1	83,9	48,4	480,0	223,4	82,6	47,0	
540		457,6	198,7	78,7	N/A	449,9	202,5	77,4	N/A	442,0	206,5	76,0	N/A	
600		609,9	274,9	104,9	59,9	600,8	281,2	103,4	58,3	591,6	287,7	101,8	56,6	
640		631,7	283,9	108,7	59,3	622,3	290,4	107,1	57,6	612,7	297,2	105,4	55,9	
680		708,5	306,7	121,9	43,8	696,8	312,4	119,9	42,5	684,9	318,2	117,8	41,2	
760		658,8	284,1	113,3	N/A	647,5	289,8	111,4	N/A	636,0	295,6	109,4	N/A	
840		872,1	371,7	150,0	66,9	858,2	378,7	147,6	64,9	844,1	385,9	145,2	62,9	
960		990,2	429,7	170,4	67,9	975,2	438,2	167,8	65,9	960,0	446,9	165,2	64,0	
1080		915,3	397,4	157,5	N/A	899,7	405,1	154,8	N/A	884,0	412,9	152,1	N/A	
13 °C		200	217,0	87,5	37,3	46,4	213,5	89,1	36,7	45,1	210,0	90,6	36,1	43,7
		230	243,9	105,7	42,0	57,6	239,9	107,6	41,3	55,9	235,8	109,7	40,6	54,1
	270	182,7	69,0	31,4	N/A	179,7	70,3	30,9	N/A	176,7	71,7	30,4	N/A	
	300	321,9	131,2	55,4	52,3	316,9	133,7	54,5	50,8	311,8	136,2	53,6	49,3	
	340	363,9	154,5	62,6	37,0	357,9	157,3	61,6	35,9	349,9	160,0	60,4	34,7	
	380	338,5	143,2	58,2	N/A	332,7	146,0	57,2	N/A	326,8	148,9	56,2	N/A	
	420	448,1	187,2	77,1	54,4	441,0	190,7	75,9	52,8	433,8	194,3	74,6	51,2	
	480	507,1	216,5	87,2	52,1	499,4	220,7	85,9	50,6	491,2	224,1	84,6	49,6	
	540	469,5	200,0	80,8	N/A	461,5	203,9	79,4	N/A	453,6	207,3	78,4	N/A	
	600	624,2	277,1	107,4	62,6	614,9	283,5	105,8	60,9	605,6	290,1	104,2	59,1	
	640	646,6	286,2	111,2	62,0	637,0	292,8	109,6	60,2	627,2	299,6	107,9	58,5	
	680	727,9	309,0	125,2	46,1	715,8	314,7	123,2	44,7	697,8	321,1	121,6	43,9	
	760	677,1	286,3	116,5	N/A	665,4	292,0	114,5	N/A	653,6	297,8	112,4	N/A	
	840	896,2	374,4	154,2	70,4	882,0	381,4	151,7	68,3	867,6	388,6	149,3	66,2	
	960	1014	433,0	174,5	71,0	998,9	441,5	171,8	69,0	977,5	448,3	170,6	69,6	
	1080	938,9	400,1	161,5	N/A	923,1	407,8	158,8	N/A	911,3	414,6	155,6	N/A	

Performance data are available up to 52°C on request

Values in grey cells : derating capacity, compressor(s) unload due to high discharge temperature
 N/A : Pressure drop of derating capacity need to be calculated thanks to page 15

Pf :
 Net cooling capacity in kW

Pe :
 Effective absorbed power in cooling mode

Wf :
 Water flow in m³ per hour

Dp :
 Water pressure drop in kPa

COOLING CAPACITIES

NAC		Outdoor air temperature																				
		28				30				32				35				37				
		Pf	Pe	Wf	Dp	Pf	Pe	Wf	Dp	Pf	Pe	Wf	Dp	Pf	Pe	Wf	Dp	Pf	Pe	Wf	Dp	
		kW	kW	m ³ /h	kPa	kW	kW	m ³ /h	kPa	kW	kW	m ³ /h	kPa	kW	kW	m ³ /h	kPa	kW	kW	m ³ /h	kPa	
Water outlet temperature	14 °C	200	274,5	67,8	47,2	71,8	268,6	69,9	46,2	68,9	262,6	72,1	45,2	66,1	253,3	75,7	43,6	61,8	246,8	78,2	42,5	58,9
		230	310,4	81,4	53,4	90,1	303,5	83,9	52,2	86,4	296,4	86,5	51,0	82,7	285,5	90,9	49,1	77,2	278,0	94,0	47,8	73,4
		270	358,4	101,7	61,7	93,1	350,2	104,8	60,3	89,1	341,7	108,2	58,8	85,1	328,6	113,7	56,5	79,1	319,6	117,8	55,0	75,1
		300	406,2	100,8	69,9	80,1	397,5	103,9	68,4	77,0	388,6	107,2	66,8	73,9	374,8	112,6	64,5	69,1	365,4	116,5	62,9	66,0
		340	463,5	118,9	79,7	57,9	453,1	122,6	78,0	55,6	442,6	126,5	76,1	53,2	426,2	132,9	73,3	49,6	415,0	137,5	71,4	47,2
		380	509,5	142,3	87,7	69,0	497,8	146,7	85,6	66,1	485,8	151,4	83,6	63,2	467,3	159,2	80,4	58,8	454,5	164,9	78,2	55,9
		420	566,5	143,6	97,5	84,0	554,3	148,1	95,4	80,7	541,8	152,8	93,2	77,3	522,4	160,6	89,9	72,3	509,2	166,2	87,6	68,9
		480	631,0	164,3	108,6	78,3	618,4	169,6	106,4	75,4	605,4	175,2	104,2	72,5	585,1	184,5	100,7	68,0	571,1	191,3	98,3	65,0
		540	677,8	189,6	116,6	89,5	664,6	195,9	114,3	86,3	650,8	202,8	112,0	83,0	629,1	214,6	108,2	77,9	613,9	223,2	105,6	74,4
		600	767,1	204,0	132,0	92,5	753,2	210,6	129,6	89,4	738,7	218,0	127,1	86,1	715,8	230,6	123,1	81,2	699,7	240,0	120,4	77,7
	640	795,4	210,5	136,8	91,7	781,0	217,3	134,4	88,6	765,9	225,0	131,8	85,4	742,0	238,0	127,7	80,4	725,2	247,8	124,8	77,0	
	680	926,9	237,9	159,5	72,4	906,3	245,2	155,9	69,4	885,2	253,1	152,3	66,4	852,5	265,8	146,7	61,9	830,1	275,0	142,8	58,9	
	760	1019	284,7	175,3	86,4	995,6	293,4	171,3	82,7	971,6	302,8	167,2	79,0	934,5	318,4	160,8	73,5	909,1	329,8	156,4	69,8	
	840	1132	287,2	194,9	109,1	1108	296,1	190,7	104,8	1083	305,7	186,4	100,4	1044	321,3	179,8	93,8	1018	332,5	175,2	89,4	
	960	1261	328,7	217,1	107,2	1236	339,2	212,8	103,2	1210	350,5	208,3	99,2	1170	369,1	201,3	93,0	1142	382,5	196,5	88,8	
	1080	1355	379,2	233,2	122,7	1329	391,8	228,7	118,2	1301	405,7	223,9	113,7	1258	429,1	216,5	106,6	1227	446,5	211,2	101,8	
	15 °C	200	281,9	68,4	48,5	75,3	275,8	70,5	47,5	72,4	269,6	72,7	46,4	69,4	260,0	76,3	44,7	64,9	253,4	78,8	43,6	61,9
		230	318,5	82,2	54,8	94,5	311,4	84,7	53,6	90,6	304,1	87,4	52,3	86,7	292,9	91,7	50,4	80,9	285,2	94,8	49,1	77,0
		270	367,5	102,7	63,2	97,5	359,0	105,9	61,8	93,3	350,3	109,3	60,3	89,2	336,9	114,9	58,0	82,9	327,6	118,9	56,4	78,6
		300	417,1	101,7	71,8	84,1	408,2	104,7	70,2	80,8	399,0	108,1	68,6	77,5	384,9	113,5	66,2	72,6	375,2	117,5	64,6	69,3
340		475,7	120,0	81,8	60,8	465,1	123,7	80,0	58,3	454,2	127,7	78,1	55,8	437,5	134,1	75,3	52,0	426,0	138,7	73,3	49,5	
380		522,4	143,9	89,9	72,3	510,4	148,3	87,8	69,2	498,1	153,0	85,7	66,2	479,0	160,8	82,4	61,6	466,0	166,5	80,2	58,5	
420		581,6	144,9	100,1	88,2	569,0	149,3	97,9	84,7	556,2	154,1	95,7	81,2	536,3	161,9	92,3	75,9	522,7	167,6	89,9	72,4	
480		645,7	165,9	111,1	81,8	632,8	171,1	108,9	78,7	619,4	176,8	106,6	75,7	598,7	186,1	103,0	71,0	584,3	192,9	100,5	67,8	
540		692,9	191,2	119,2	93,3	679,3	197,6	116,9	89,9	665,2	204,6	114,4	86,4	643,0	216,5	110,6	81,1	627,5	225,2	108,0	77,5	
600		783,8	205,3	134,8	96,4	769,6	212,0	132,4	93,1	754,8	219,5	129,9	89,7	731,4	232,3	125,8	84,5	715,0	241,8	123,0	81,0	
640	812,7	211,8	139,8	95,6	798,0	218,7	137,3	92,3	782,6	226,5	134,6	89,0	758,2	239,8	130,4	83,8	741,1	249,7	127,5	80,2		
680	951,3	240,1	163,7	76,0	930,1	247,4	160,0	72,9	908,4	255,3	156,3	69,7	874,9	268,1	150,5	65,0	851,9	277,4	146,6	61,8		
760	1044	287,8	179,8	90,5	1020	296,5	175,6	86,7	996,2	306,0	171,4	82,8	958,1	321,7	164,8	77,0	932,0	333,0	160,3	73,1		
840	1163	289,8	200,1	114,6	1138	298,7	195,8	110,0	1112	308,3	191,4	105,4	1072	323,9	184,5	98,5	1045	335,1	179,9	93,9		
960	1291	331,7	222,2	112,0	1265	342,2	217,7	107,8	1238	353,6	213,1	103,5	1197	372,3	206,0	97,1	1168	385,8	201,1	92,8		
1080	1385	382,4	238,4	127,9	1358	395,1	233,8	123,2	1330	409,2	228,9	118,4	1286	432,9	221,2	111,1	1255	450,5	215,9	106,1		

Performance data are available up 52°C on request.

Pf :
 Net cooling capacity in kW

Pe :
 Effective absorbed power in cooling mode

Wf :
 Water flow in m³ per hour

Dp :
 Water pressure drop in KPa

COOLING CAPACITIES

NAC		Outdoor air temperature																				
		39				40				41				42				43				
		Pf	Pe	Wf	Dp	Pf	Pe	Wf	Dp	Pf	Pe	Wf	Dp	Pf	Pe	Wf	Dp	Pf	Pe	Wf	Dp	
		kW	kW	m³/h	kPa	kW	kW	m³/h	kPa	kW	kW	m³/h	kPa	kW	kW	m³/h	kPa	kW	kW	m³/h	kPa	
Water outlet temperature	14 °C	200	240,2	80,9	41,3	56,0	236,9	82,3	40,7	54,6	233,4	83,7	40,2	53,2	230,0	85,1	39,6	51,7	226,5	86,6	39,0	50,3
		230	270,3	97,3	46,5	69,7	266,4	99,1	45,8	67,9	262,5	100,9	45,2	66,0	258,5	102,7	44,5	64,2	254,4	104,6	43,8	62,3
		270	310,3	122,0	53,4	71,1	305,6	124,2	52,6	69,1	300,8	126,5	51,8	67,1	296,0	128,8	50,9	65,1	291,1	131,2	50,1	63,1
		300	355,7	120,7	61,2	62,8	350,9	122,9	60,4	61,3	345,9	125,1	59,5	59,7	340,9	127,4	58,7	58,1	335,9	129,7	57,8	56,5
		340	403,6	142,4	69,4	44,8	397,7	144,9	68,4	43,6	391,8	147,5	67,4	42,4	385,9	150,2	66,4	41,3	379,8	152,9	65,3	40,1
		380	441,5	171,0	76,0	52,9	434,9	174,1	74,8	51,5	428,2	177,4	73,7	50,0	421,4	180,8	72,5	48,6	353,7	141,6	60,9	N/A
		420	495,6	172,2	85,3	65,6	488,7	175,3	84,1	63,9	481,7	178,5	82,9	62,2	474,6	181,7	81,7	60,5	467,5	185,1	80,4	58,9
		480	556,8	198,4	95,8	62,0	549,4	202,1	94,5	60,5	542,0	206,0	93,2	59,0	534,4	209,9	91,9	57,4	526,8	214,0	90,6	55,9
		540	598,2	232,6	102,9	70,9	590,2	237,5	101,5	69,1	582,0	242,6	100,1	67,3	573,6	247,9	98,7	65,5	489,3	197,7	84,2	N/A
		600	683,0	250,2	117,5	74,3	674,4	255,7	116,0	72,5	665,6	261,3	114,5	70,7	656,7	267,1	113,0	69,0	647,7	273,2	111,4	67,2
	640	707,8	258,4	121,8	73,6	698,9	264,0	120,2	71,8	689,8	269,8	118,7	70,0	680,5	275,9	117,1	68,3	671,1	282,1	115,5	66,5	
	680	807,1	284,7	138,9	55,9	795,4	289,8	136,9	54,4	783,6	295,0	134,8	52,9	771,7	300,3	132,8	51,4	759,7	305,8	130,7	49,9	
	760	883,0	341,9	151,9	66,1	869,8	348,3	149,6	64,3	856,4	354,8	147,3	62,5	842,9	361,6	145,0	60,6	707,4	283,1	121,7	N/A	
	840	991,2	344,4	170,5	85,0	977,4	350,6	168,1	82,8	963,4	356,9	165,7	80,6	949,3	363,5	163,3	78,4	935,0	370,2	160,9	76,2	
	960	1113	396,8	191,6	84,7	1098	404,3	189,0	82,6	1084	412,0	186,5	80,5	1068	419,9	183,9	78,4	1053	428,0	181,3	76,3	
	1080	1196	465,2	205,8	97,0	1180	475,1	203,1	94,5	1164	485,3	200,3	92,0	1147	495,9	197,4	89,6	978,6	395,3	168,4	N/A	
	15 °C	200	246,7	81,5	42,4	58,9	243,2	82,8	41,8	57,3	239,7	84,3	41,2	55,8	236,2	85,7	40,6	54,3	232,6	87,2	40,0	52,8
		230	277,3	98,2	47,7	73,1	273,3	99,9	47,0	71,2	269,3	101,7	46,3	69,2	265,2	103,5	45,6	67,3	261,0	105,4	44,9	65,4
		270	318,1	123,1	54,7	74,4	313,3	125,4	53,9	72,3	308,4	127,7	53,1	70,2	303,5	130,0	52,2	68,2	196,5	68,7	33,8	N/A
		300	365,3	121,6	62,9	66,0	360,3	123,8	62,0	64,3	355,3	126,0	61,1	62,7	350,2	128,3	60,2	61,0	345,0	130,7	59,4	59,4
340		414,2	143,6	71,3	47,0	408,2	146,1	70,2	45,8	402,2	148,7	69,2	44,5	396,1	151,4	68,1	43,3	389,9	154,1	67,1	42,1	
380		452,6	172,6	77,9	55,4	445,9	175,8	76,7	53,9	439,0	179,1	75,5	52,4	432,1	182,4	74,3	50,9	363,2	142,7	62,5	N/A	
420		508,8	173,5	87,5	68,8	501,7	176,6	86,3	67,1	494,6	179,8	85,1	65,3	487,3	183,1	83,8	63,6	480,0	186,5	82,6	61,8	
480		569,6	200,1	98,0	64,7	562,1	203,8	96,7	63,1	554,5	207,7	95,4	61,5	546,8	211,6	94,1	59,9	539,0	215,7	92,7	58,3	
540		611,4	234,7	105,2	73,8	603,2	239,7	103,8	72,0	594,8	244,8	102,3	70,1	586,3	250,2	100,9	68,3	501,3	199,1	86,2	N/A	
600		698,0	252,2	120,1	77,4	689,2	257,7	118,6	75,5	680,3	263,4	117,0	73,7	671,2	269,3	115,5	71,9	662,0	275,4	113,9	70,0	
640	723,4	260,4	124,5	76,6	714,3	266,1	122,9	74,8	705,0	272,0	121,3	73,0	695,6	278,1	119,7	71,2	686,0	284,4	118,0	69,3		
680	828,4	287,1	142,5	58,7	816,4	292,2	140,5	57,1	804,4	297,4	138,4	55,6	792,2	302,7	136,3	54,0	726,3	285,5	125,0	N/A		
760	905,3	345,2	155,7	69,3	891,7	351,6	153,4	67,3	878,0	358,1	151,1	65,4	864,1	364,9	148,7	63,5	850,1	371,8	146,3	61,6		
840	1017	347,1	175,1	89,3	1003	353,3	172,6	87,0	989,1	359,7	170,2	84,7	974,7	366,2	167,7	82,4	960,1	372,9	165,2	80,1		
960	1139	400,1	196,0	88,4	1124	407,6	193,4	86,2	1109	415,4	190,8	84,0	1093	423,3	188,1	81,8	1077	431,4	185,4	79,6		
1080	1222	469,4	210,4	101,0	1206	479,4	207,6	98,5	1189	489,7	204,7	95,9	1172	500,4	201,7	93,4	1002	398,1	172,5	N/A		

Performance data are available up 52°C on request

Values in grey cells : derating capacity, compressor(s) unload due to high discharge temperature
 N/A : Pressure drop of derating capacity need to be calculated thanks to page 15

Pf :
 Net cooling capacity in kW

Pe :
 Effective absorbed power in cooling mode

Wf :
 Water flow in m³ per hour

Dp :
 Water pressure drop in kPa

COOLING CAPACITIES

NAC		Outdoor air temperature												
		44				45				46				
		Pf	Pe	Wf	Dp	Pf	Pe	Wf	Dp	Pf	Pe	Wf	Dp	
		kW	kW	m³/h	kPa	kW	kW	m³/h	kPa	kW	kW	m³/h	kPa	
Water outlet temperature	14 °C	200	223,0	88,1	38,4	48,8	219,4	89,6	37,8	47,4	215,8	91,2	37,1	46,0
		230	250,3	106,5	43,1	60,5	246,2	108,4	42,4	58,7	242,0	110,5	41,6	56,8
		270	188,0	69,5	32,3	N/A	184,9	70,8	31,8	N/A	181,8	72,2	31,3	N/A
		300	330,8	132,1	56,9	55,0	325,7	134,6	56,0	53,4	320,5	137,1	55,1	51,9
		340	373,7	155,7	64,3	38,9	367,6	158,5	63,2	37,7	307,3	130,9	52,9	N/A
		380	347,7	144,3	59,8	N/A	341,7	147,2	58,8	N/A	335,6	150,1	57,7	N/A
		420	460,3	188,5	79,2	57,2	453,0	192,0	77,9	55,5	445,7	195,6	76,7	53,9
		480	519,1	218,2	89,3	54,4	511,2	222,4	88,0	52,9	373,7	145,2	64,3	N/A
		540	481,3	201,4	82,8	N/A	473,2	205,3	81,4	N/A	406,2	165,9	69,9	N/A
		600	638,4	279,4	109,8	65,4	629,0	285,8	108,2	63,6	463,0	181,6	79,7	N/A
	640	661,4	288,6	113,8	64,7	651,7	295,2	112,1	62,9	479,5	187,3	82,5	N/A	
	680	747,5	311,4	128,6	48,4	735,2	317,1	126,5	47,0	614,5	261,9	105,7	N/A	
	760	695,5	288,6	119,7	N/A	683,5	294,3	117,6	N/A	671,3	300,1	115,5	N/A	
	840	920,6	377,1	158,4	74,0	906,0	384,1	155,9	71,8	891,3	391,3	153,3	69,7	
	960	1038,1	436,3	178,6	74,2	1022,5	444,9	175,9	72,1	747,4	290,3	128,6	N/A	
	1080	962,6	402,8	165,6	N/A	946,4	410,5	162,8	N/A	812,4	331,9	139,8	N/A	
	15 °C	200	229,0	88,7	39,4	51,3	225,4	90,2	38,8	49,8	221,7	91,8	38,1	48,3
		230	256,8	107,3	44,2	63,4	252,6	109,3	43,5	61,5	184,9	72,4	31,8	N/A
		270	193,3	70,0	33,3	N/A	190,2	71,3	32,7	N/A	187,0	72,7	32,2	N/A
		300	339,8	133,1	58,5	57,8	334,5	135,6	57,6	56,1	329,2	138,1	56,6	54,5
340		383,7	156,9	66,0	40,8	321,3	129,4	55,3	N/A	315,7	131,9	54,3	N/A	
380		357,0	145,5	61,4	N/A	350,8	148,4	60,4	N/A	344,6	151,3	59,3	N/A	
420		472,7	189,9	81,3	60,1	465,2	193,4	80,0	58,3	387,9	157,3	66,7	N/A	
480		531,0	219,9	91,4	56,8	523,0	224,2	90,0	55,2	383,7	146,2	66,0	N/A	
540		493,1	202,8	84,8	N/A	484,8	206,7	83,4	N/A	416,8	166,9	71,7	N/A	
600		652,6	281,7	112,3	68,1	643,1	288,2	110,6	66,3	475,2	182,4	81,8	N/A	
640	676,2	290,9	116,3	67,4	666,3	297,6	114,6	65,6	492,1	188,1	84,7	N/A		
680	714,0	291,0	122,8	N/A	642,6	258,8	110,6	N/A	631,4	263,7	108,6	N/A		
760	836,0	379,0	143,8	59,7	701,6	296,7	120,7	N/A	689,1	302,6	118,6	N/A		
840	945,3	379,8	162,6	77,8	930,4	386,9	160,1	75,5	775,8	314,7	133,5	N/A		
960	1062	439,8	182,7	77,4	1046,1	448,4	180,0	75,3	767,4	292,4	132,0	N/A		
1080	986,2	405,6	169,7	N/A	969,6	413,4	166,8	N/A	833,6	333,8	143,4	N/A		

Performance data are available up 52°C on request

 Values in grey cells : derating capacity, compressor(s) unload due to high discharge temperature
 N/A : Pressure drop of derating capacity need to be calculated thanks to page 15

Pf :
 Net cooling capacity in kW

Pe :
 Effective absorbed power in cooling mode

Wf :
 Water flow in m³ per hour

Dp :
 Water pressure drop in KPa

COOLING MODE

NAH		Outdoor air temperature																
		28°C				30°C				32°C				35°C				
		Pf	Pe	Wf	Dp	Pf	Pe	Wf	Dp	Pf	Pe	Wf	Dp	Pf	Pe	Wf	Dp	
		kW	kW	m³/h	kPa	kW	kW	m³/h	kPa	kW	kW	m³/h	kPa	kW	kW	m³/h	kPa	
Water outlet temperature	5°C	200	196,0	64,0	33,7	38,4	191,5	66,3	32,9	36,8	186,9	68,6	32,2	35,2	179,9	72,4	30,9	32,8
		230	223,3	75,0	38,4	48,9	218,0	77,7	37,5	46,8	212,6	80,6	36,6	44,7	204,5	85,2	35,2	41,6
		270	277,0	92,9	47,7	57,5	270,9	96,2	46,6	55,1	264,6	99,7	45,5	52,7	254,9	105,2	43,9	49,2
		300	303,2	101,4	52,2	46,9	296,1	105,1	50,9	44,9	289,0	109,0	49,7	42,9	278,1	115,3	47,9	40,0
		340	334,0	111,4	57,5	31,6	325,8	115,5	56,1	30,2	317,5	119,8	54,6	28,8	305,0	126,4	52,5	26,7
		380	370,3	115,8	63,7	38,2	361,8	120,0	62,2	36,6	353,1	124,4	60,8	35,0	339,8	131,3	58,5	32,6
		420	408,7	134,3	70,3	45,9	399,0	139,3	68,6	43,9	389,2	144,6	67,0	41,9	374,3	152,8	64,4	39,0
		480	465,5	154,5	80,1	44,4	455,0	160,5	78,3	42,5	444,5	166,7	76,5	40,7	428,5	176,5	73,7	38,0
	6°C	200	201,9	64,6	34,7	40,6	197,3	66,9	33,9	38,9	192,6	69,2	33,1	37,2	185,4	73,0	31,9	34,7
		230	229,9	75,8	39,6	51,7	224,5	78,5	38,6	49,4	219,0	81,4	37,7	47,2	210,7	85,9	36,2	44,0
		270	285,6	93,7	49,1	60,9	279,3	97,0	48,0	58,4	272,8	100,4	46,9	55,9	262,9	106,0	45,2	52,1
		300	312,3	102,4	53,7	49,5	305,1	106,1	52,5	47,4	297,8	109,9	51,2	45,4	286,7	116,1	49,3	42,3
		340	344,0	112,4	59,2	33,4	335,5	116,5	57,7	31,9	327,1	120,8	56,3	30,4	314,3	127,4	54,1	28,2
		380	381,6	116,7	65,7	40,4	372,9	120,9	64,1	38,7	363,9	125,3	62,6	37,0	350,3	132,2	60,3	34,5
		420	421,1	135,5	72,5	48,5	411,1	140,5	70,7	46,4	401,1	145,7	69,0	44,3	385,8	153,9	66,4	41,2
		480	478,9	156,0	82,4	46,8	468,2	162,0	80,5	44,9	457,4	168,2	78,7	42,9	441,1	177,9	75,9	40,1
	7°C	200	207,9	65,2	35,8	42,9	203,2	67,5	35,0	41,1	198,4	69,8	34,1	39,3	191,0	73,5	32,9	36,7
		230	236,6	76,7	40,7	54,5	231,1	79,4	39,8	52,2	225,5	82,2	38,8	49,9	217,0	86,7	37,3	46,4
		270	294,4	94,5	50,6	64,4	287,8	97,8	49,5	61,7	281,2	101,2	48,4	59,1	271,0	106,7	46,6	55,2
		300	321,6	103,4	55,3	52,2	314,2	107,0	54,1	50,0	306,7	110,9	52,8	47,9	295,4	117,0	50,8	44,7
		340	354,0	113,5	60,9	35,2	345,4	117,6	59,4	33,6	336,7	121,8	57,9	32,1	323,6	128,4	55,7	29,8
		380	393,1	117,7	67,6	42,7	384,1	121,8	66,1	40,9	374,9	126,2	64,5	39,1	360,9	133,1	62,1	36,5
		420	433,6	136,7	74,6	51,2	423,4	141,7	72,8	49,0	413,1	146,9	71,1	46,8	397,5	155,1	68,4	43,6
		480	492,2	157,6	84,7	49,2	481,3	163,5	82,8	47,2	470,3	169,7	80,9	45,2	453,7	179,4	78,1	42,3

Pf : Net cooling capacity in kW	Pe : Effective absorbed power in cooling mode	Wf : Water flow in m³ per hour	Dp : Water pressure drop in KPa
---	---	--	---

HEATING MODE

NAH		Water outlet temperature																
		30°C				35°C				40°C				45°C				
		Ph	Pe	Wf	Dp	Ph	Pe	Wf	Dp	Ph	Pe	Wf	Dp	Ph	Pe	Wf	Dp	
		kW	kW	m³/h	kPa	kW	kW	m³/h	kPa	kW	kW	m³/h	kPa	kW	kW	m³/h	kPa	
Outdoor air temperature	20°C	200	322,6	55,8	55,5	96,8	315,9	61,0	54,4	93,1	308,7	66,8	53,1	89,2	301,1	73,2	51,8	85,1
		230	369,2	65,4	63,5	124,2	362,0	71,9	62,3	119,8	354,3	79,0	61,0	115,1	346,0	86,7	59,5	110,1
		270	464,7	82,7	79,9	151,2	452,6	90,3	77,9	143,9	441,0	98,9	75,9	137,1	429,8	108,6	74,0	130,7
		300	511,3	90,7	88,0	122,2	498,6	99,3	85,8	116,7	486,5	108,9	83,7	111,5	474,8	119,5	81,7	106,7
		340	546,8	96,7	94,1	78,7	534,3	105,3	91,9	75,4	522,2	115,1	89,8	72,2	510,6	126,3	87,8	69,3
		380	609,2	107,6	104,8	96,1	594,1	116,9	102,2	91,7	579,3	127,7	99,7	87,5	565,0	139,9	97,2	83,6
		420	680,1	122,0	117,0	117,8	663,6	132,8	114,2	112,6	647,7	145,3	111,4	107,6	632,3	159,3	108,8	102,9
		480	753,4	134,5	129,6	109,0	735,8	146,4	126,6	104,3	718,9	160,1	123,7	99,9	702,7	175,6	120,9	95,7
	15°C	200	284,5	54,6	48,9	76,7	279,1	59,8	48,0	74,0	273,1	65,6	47,0	71,1	266,7	72,0	45,9	68,0
		230	324,9	63,6	55,9	98,0	319,3	70,2	54,9	94,9	313,2	77,4	53,9	91,6	306,4	85,1	52,7	88,0
		270	409,2	80,9	70,4	119,2	399,3	88,4	68,7	113,9	389,8	97,1	67,1	108,8	380,7	106,8	65,5	104,2
		300	449,7	88,3	77,4	96,6	439,5	97,0	75,6	92,6	429,7	106,6	73,9	88,8	420,5	117,3	72,3	85,4
		340	480,4	94,6	82,7	61,9	470,2	103,2	80,9	59,5	460,5	113,1	79,2	57,2	451,1	124,4	77,6	55,1
		380	536,3	105,6	92,3	75,9	523,7	115,0	90,1	72,6	511,5	125,7	88,0	69,5	499,6	137,9	86,0	66,6
		420	597,6	119,1	102,8	92,7	584,2	130,0	100,5	88,9	571,4	142,6	98,3	85,3	559,1	156,7	96,2	82,0
		480	661,0	130,7	113,7	85,4	646,9	142,9	111,3	82,0	633,5	156,9	109,0	78,9	620,9	172,7	106,8	76,0
	10°C	200	249,9	53,5	43,0	60,3	245,7	58,7	42,3	58,4	241,0	64,5	41,5	56,4	235,8	71,0	40,6	54,2
		230	284,9	62,1	49,0	76,8	280,9	68,8	48,3	74,9	276,3	76,0	47,5	72,6	271,1	83,8	46,6	70,1
		270	359,1	79,3	61,8	93,4	351,2	86,8	60,4	89,6	343,8	95,5	59,1	86,1	336,8	105,2	57,9	82,8
		300	394,1	86,3	67,8	75,8	386,3	95,0	66,5	73,1	378,9	104,8	65,2	70,5	372,2	115,5	64,0	68,2
		340	420,6	92,7	72,4	48,4	412,7	101,3	71,0	46,7	405,3	111,3	69,7	45,2	398,2	122,6	68,5	43,7
		380	470,4	103,8	80,9	59,5	460,3	113,1	79,2	57,2	450,6	123,8	77,5	55,0	441,2	135,9	75,9	52,9
		420	523,2	116,6	90,0	72,5	512,9	127,6	88,2	69,9	503,2	140,2	86,6	67,4	494,0	154,5	85,0	65,2
		480	577,9	127,5	99,4	66,5	567,3	140,0	97,6	64,2	557,5	154,2	95,9	62,1	548,4	170,3	94,3	60,3
	7°C	200	230,8	52,9	39,7	52,1	227,4	58,1	39,1	50,6	223,5	63,9	38,4	49,0	219,0	70,4	37,68	47,2
		230	262,9	61,3	45,2	66,2	259,8	68,0	44,7	64,8	256,2	75,3	44,1	63,1	252,0	83,2	43,35	61,2
		270	331,5	78,4	57,0	80,4	324,9	86,0	55,9	77,4	318,7	94,6	54,8	74,7	313,0	104,3	53,84	72,2
		300	363,6	85,3	62,6	65,4	357,2	94,0	61,5	63,3	351,3	103,8	60,4	61,4	346,0	114,6	59,53	59,7
		340	387,9	91,6	66,7	41,7	381,4	100,3	65,6	40,4	375,3	110,3	64,6	39,2	369,7	121,7	63,60	38,1
		380	434,2	102,7	74,7	51,3	425,6	112,0	73,2	49,5	417,4	122,7	71,8	47,7	409,5	134,8	70,45	46,1
		420	482,6	115,2	83,0	62,4	474,1	126,3	81,6	60,4	466,2	139,0	80,2	58,6	458,9	153,3	78,94	56,9
		480	532,5	125,9	91,6	57,0	524,0	138,5	90,2	55,4	516,3	153,0	88,8	53,9	509,3	169,2	87,63	52,5
	5°C	200	218,8	52,5	37,6	47,2	215,9	57,7	37,1	46,0	212,4	63,5	36,6	44,6	208,5	70,0	35,9	43,1
		230	249,1	60,8	42,9	59,9	246,7	67,6	42,4	58,9	243,7	74,9	41,9	57,5	240,1	82,8	41,3	56,0
		270	314,1	77,9	54,0	72,7	308,3	85,4	53,0	70,2	303,0	94,1	52,1	68,0	298,1	103,8	51,3	65,9
		300	344,4	84,7	59,3	59,2	339,0	93,5	58,3	57,5	334,1	103,3	57,5	56,0	329,7	114,1	56,7	54,7
		340	367,4	91,0	63,2	37,7	361,8	99,7	62,2	36,6	356,7	109,7	61,4	35,7	351,9	121,1	60,5	34,8
		380	411,5	102,1	70,8	46,5	403,9	111,3	69,5	44,9	396,6	121,9	68,2	43,4	389,8	134,0	67,1	42,0
		420	457,1	114,4	78,6	56,4	449,9	125,5	77,4	54,8	443,2	138,2	76,2	53,3	437,1	152,6	75,2	52,0
		480	504,1	125,0	86,7	51,5	497,0	137,7	85,5	50,2	490,7	152,2	84,4	49,0	485,2	168,5	83,5	47,9
	0°C	200	191,3	51,5	32,9	36,8	189,6	56,8	32,6	36,2	187,4	62,6	32,2	35,4	184,7	69,1	31,8	34,4
		230	217,6	59,8	37,4	46,7	216,7	66,7	37,3	46,3	215,3	74,1	37,0	45,8	213,3	82,1	36,7	45,0
		270	274,4	76,7	47,2	56,4	270,7	84,3	46,6	55,1	267,5	92,9	46,0	53,8	264,7	102,6	45,5	52,8
		300	300,7	83,5	51,7	46,2	297,7	92,4	51,2	45,3	295,3	102,2	50,8	44,6	293,3	113,1	50,5	44,1
		340	320,7	89,5	55,2	29,3	317,5	98,3	54,6	28,8	314,6	108,4	54,1	28,3	312,2	119,8	53,7	27,9
		380	359,5	100,4	61,9	36,2	354,4	109,6	61,0	35,3	349,7	120,2	60,2	34,4	345,3	132,2	59,4	33,6
		420	399,1	112,6	68,7	43,9	395,0	123,8	68,0	43,1	391,4	136,6	67,3	42,4	388,3	151,1	66,8	41,7
		480	439,6	123,0	75,6	39,9	436,0	136,0	75,0	39,3	433,3	150,8	74,5	38,8	431,2	167,3	74,2	38,5

Ph :
Net heating capacity in kW - Instantaneous heating capacity (this does not take into account the formation of frost on the coil and the defrost cycles).

Pe :
Effective absorbed power in heating mode

Wf :
Water flow in m³ per hour

Dp :
Water pressure drop in KPa

HEATING MODE

NAH		Water outlet temperature																
		30°C				35°C				40°C				45°C				
		Ph	Pe	Wf	Dp	Ph	Pe	Wf	Dp	Ph	Pe	Wf	Dp	Ph	Pe	Wf	Dp	
		kW	kW	m³/h	kPa	kW	kW	m³/h	kPa	kW	kW	m³/h	kPa	kW	kW	m³/h	kPa	
Outdoor air temperature	-2 °C	200	181,2	51,2	31,2	33,3	180,1	56,4	31,0	32,9	178,4	62,3	30,7	32,3	176,1	68,8	30,3	31,6
		230	206,2	59,5	35,5	42,2	206,0	66,4	35,4	42,2	205,2	73,9	35,3	41,9	203,8	81,8	35,1	41,3
		270	259,9	76,3	44,7	51,0	257,1	83,8	44,2	50,0	254,7	92,5	43,8	49,1	252,7	102,2	43,5	48,4
		300	284,9	83,1	49,0	41,8	282,9	92,0	48,7	41,3	281,4	101,9	48,4	40,9	280,4	112,8	48,2	40,6
		340	303,9	89,0	52,3	26,5	301,6	97,8	51,9	26,1	299,6	107,9	51,6	25,8	298,1	119,4	51,3	25,6
		380	340,7	99,8	58,6	32,8	336,6	108,9	57,9	32,0	332,8	119,5	57,3	31,4	329,5	131,5	56,7	30,8
		420	378,2	111,9	65,1	39,8	375,3	123,2	64,6	39,2	372,9	136,1	64,2	38,7	371,1	150,6	63,8	38,4
		480	416,3	122,4	71,6	36,0	414,2	135,4	71,3	35,7	412,9	150,3	71,0	35,5	412,2	167,0	70,9	35,4
	-4 °C	200	171,8	50,8	29,6	30,1	171,1	56,1	29,4	29,9	169,9	62,0	29,2	29,5	168,2	68,4	28,9	29,0
		230	195,5	59,3	33,6	38,3	195,9	66,2	33,7	38,4	195,7	73,7	33,7	38,4	-	-	-	-
		270	246,3	75,9	42,4	46,1	244,3	83,5	42,0	45,5	242,8	92,1	41,8	44,9	-	-	-	-
		300	270,1	82,9	46,5	37,9	269,0	91,8	46,3	37,6	268,5	101,7	46,2	37,5	-	-	-	-
		340	288,1	88,5	49,6	24,0	286,7	97,3	49,3	23,8	285,7	107,5	49,2	23,7	-	-	-	-
		380	323,0	99,1	55,6	29,7	319,9	108,3	55,0	29,2	317,1	118,9	54,6	28,7	314,7	130,9	54,1	28,3
		420	358,6	111,3	61,7	36,0	356,9	122,6	61,4	35,7	355,8	135,6	61,2	35,5	-	-	-	-
		480	394,6	121,8	67,9	32,6	393,9	135,0	67,8	32,5	394,0	150,0	67,8	32,5	-	-	-	-
	-6 °C	200	162,9	50,5	28,0	27,3	162,7	55,8	28,0	27,2	162,0	61,7	27,9	27,0	-	-	-	-
		230	185,4	59,1	31,9	34,7	186,5	66,0	32,1	35,1	186,9	73,5	32,2	35,2	-	-	-	-
		270	233,5	75,6	40,2	41,8	232,4	83,1	40,0	41,4	231,7	91,8	39,9	41,2	-	-	-	-
		300	256,2	82,6	44,1	34,4	256,1	91,6	44,1	34,4	256,5	101,5	44,1	34,5	-	-	-	-
		340	273,4	88,0	47,0	21,8	272,9	96,9	47,0	21,7	272,8	107,1	46,9	21,7	-	-	-	-
		380	306,4	98,5	52,7	26,9	304,3	107,6	52,3	26,6	302,5	118,2	52,0	26,3	-	-	-	-
		420	340,3	110,8	58,5	32,7	339,9	122,2	58,5	32,6	340,0	135,1	58,5	32,6	-	-	-	-
		480	374,4	121,4	64,4	29,5	375,1	134,7	64,5	29,7	376,5	149,8	64,8	29,9	-	-	-	-
	-8 °C	200	154,5	50,2	26,6	24,8	154,8	55,5	26,6	24,8	154,6	61,4	26,6	24,8	-	-	-	-
		230	176,1	58,9	30,3	31,5	177,7	65,9	30,6	32,1	-	-	-	-	-	-	-	-
		270	221,6	75,3	38,1	37,9	221,3	82,8	38,1	37,8	221,4	91,5	38,1	37,8	-	-	-	-
		300	243,2	82,5	41,8	31,3	244,1	91,5	42,0	31,5	-	-	-	-	-	-	-	-
		340	259,7	87,6	44,7	19,8	260,2	96,5	44,8	19,9	261,0	106,7	44,9	20,0	-	-	-	-
		380	290,9	97,9	50,1	24,5	289,8	107,0	49,9	24,3	289,0	117,6	49,7	24,2	-	-	-	-
		420	323,3	110,4	55,6	29,7	324,1	121,7	55,8	29,9	325,5	134,7	56,0	30,1	-	-	-	-
		480	355,6	121,0	61,2	26,8	357,8	134,4	61,5	27,1	360,6	149,6	62,0	27,6	-	-	-	-
	-10 °C	200	146,7	49,9	25,2	22,5	147,5	55,2	25,4	22,7	-	-	-	-	-	-	-	-
		230	167,4	58,8	28,8	28,7	169,7	65,8	29,2	29,5	-	-	-	-	-	-	-	-
		270	210,5	75,0	36,2	34,4	211,1	82,6	36,3	34,6	-	-	-	-	-	-	-	-
		300	231,2	82,4	39,8	28,5	233,0	91,4	40,1	28,9	-	-	-	-	-	-	-	-
340		247,1	87,2	42,5	18,1	248,5	96,1	42,7	18,3	-	-	-	-	-	-	-	-	
380		276,5	97,3	47,6	22,3	276,4	106,4	47,6	22,2	276,6	117,0	47,6	22,3	-	-	-	-	
420		307,7	109,9	52,9	27,1	309,7	121,4	53,3	27,5	-	-	-	-	-	-	-	-	
480		338,4	120,8	58,2	24,5	341,9	134,3	58,8	24,9	-	-	-	-	-	-	-	-	

Ph : <i>Net heating capacity in kW - Instantaneous heating capacity (this does not take into account the formation of frost on the coil and the defrost cycles).</i>	Pe : <i>Effective absorbed power in heating mode</i>	Wf : <i>Water flow in m³ per hour</i>	Dp : <i>Water pressure drop in KPa</i>
--	--	---	--

NAC 200 / 230 / 270
NAH 200 / 230

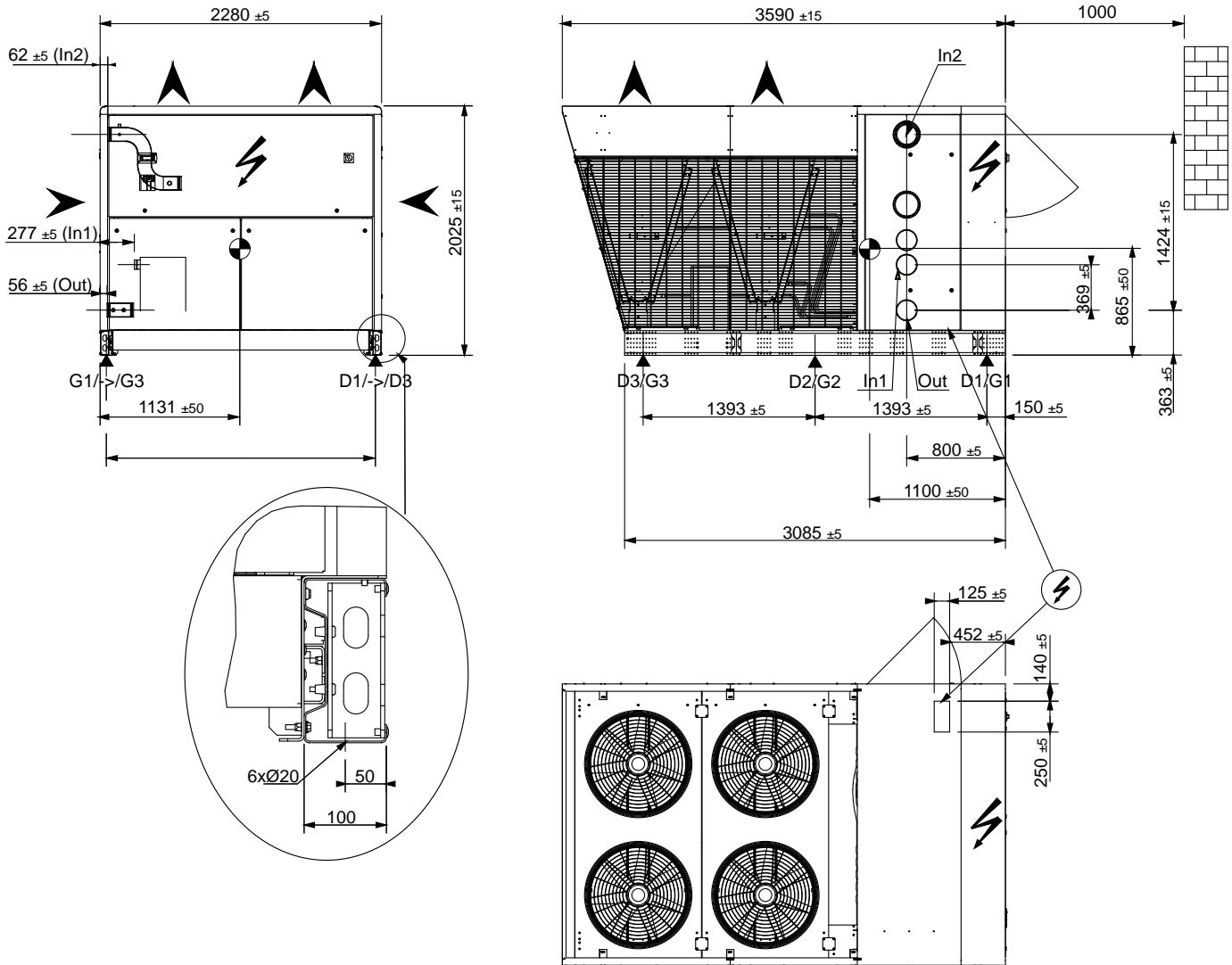

LEGEND:

	Gravity center	Ø
In 1	Chilled water inlet - Unit without hydraulic module	Ø 4" Victaulic
In 2 :	Chilled water inlet - Unit with hydraulic module	
Out :	Chilled water outlet	

LOAD DISTRIBUTION

(Kg - Lennox recommend load distribution as detailed below.)
More detailed load distributions available on page xxx

		G1/D1	G2/D2	G3/D3	G4/D4	G5/G5
NAC 200	Without hydraulic module	350	428	214	-	-
	With high pressure double pump	396	484	242	-	-
NAC 230	Without hydraulic module	355	434	217	-	-
	With high pressure double pump	414	506	253	-	-
NAC 270	Without hydraulic module	402	491	246	-	-
	With high pressure double pump	463	565	283	-	-
NAH 200	Without hydraulic module	384	469	235	-	-
	With high pressure double pump	430	526	263	-	-
NAH 230	Without hydraulic module	384	469	235	-	-
	With high pressure double pump	442	541	270	-	-

NAH 270

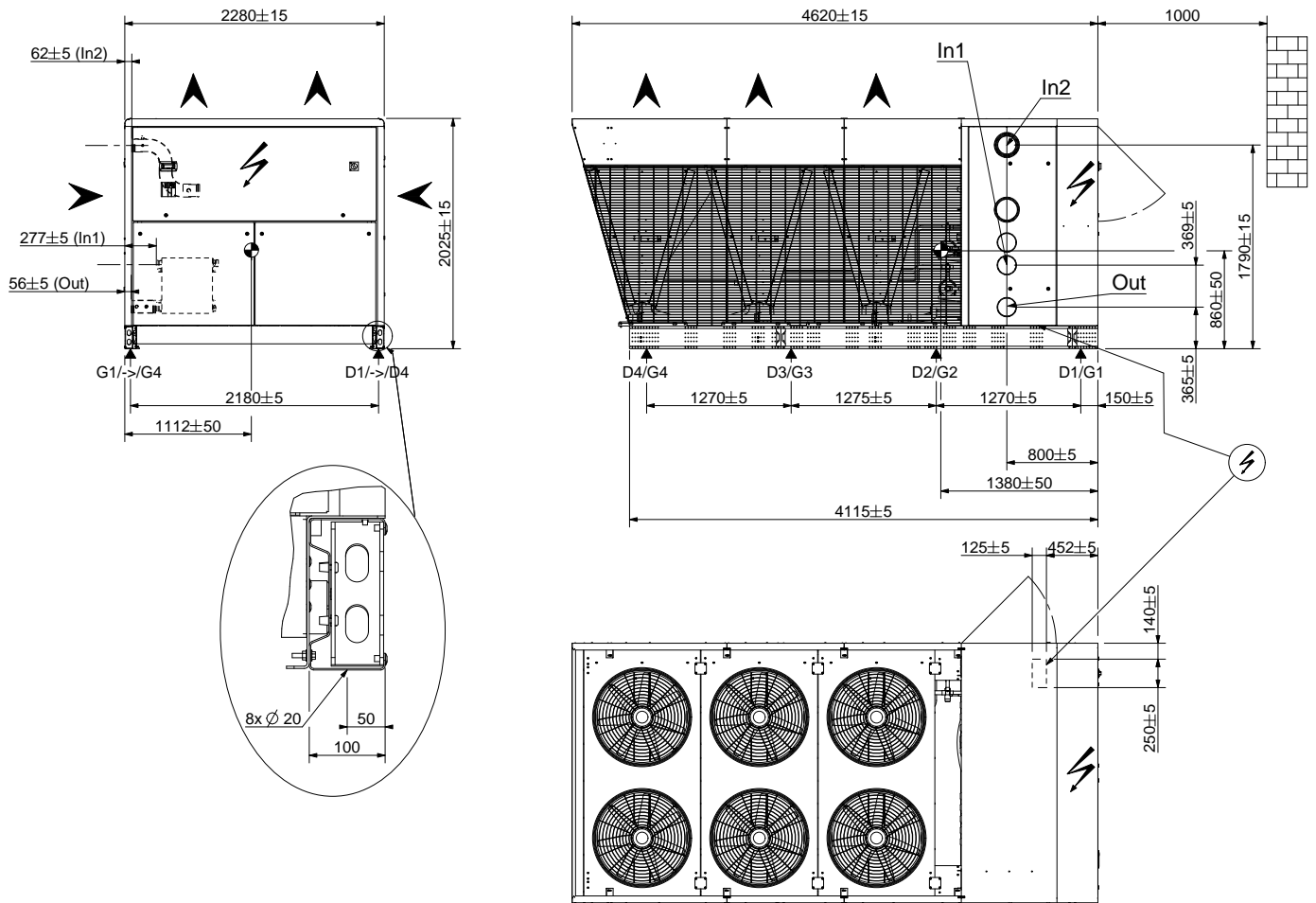

LEGEND:		Ø
	Gravity center	
In 1	Chilled water inlet - Unit without hydraulic module	Ø 4" Victaulic
In 2 :	Chilled water inlet - Unit with hydraulic module	
Out :	Chilled water outlet	

LOAD DITRIBUTION

(Kg - Lennox recommend load distribution as detailed below.)
 More detailed load distributions available on page xxx

		G1/D1	G2/D2	G3/D3	G4/D4	G5/G5
NAH 270	Without hydraulic module	369	481	361	242	0
	With high pressure double pump	413	537	404	271	0

NAC 300
NAH 300

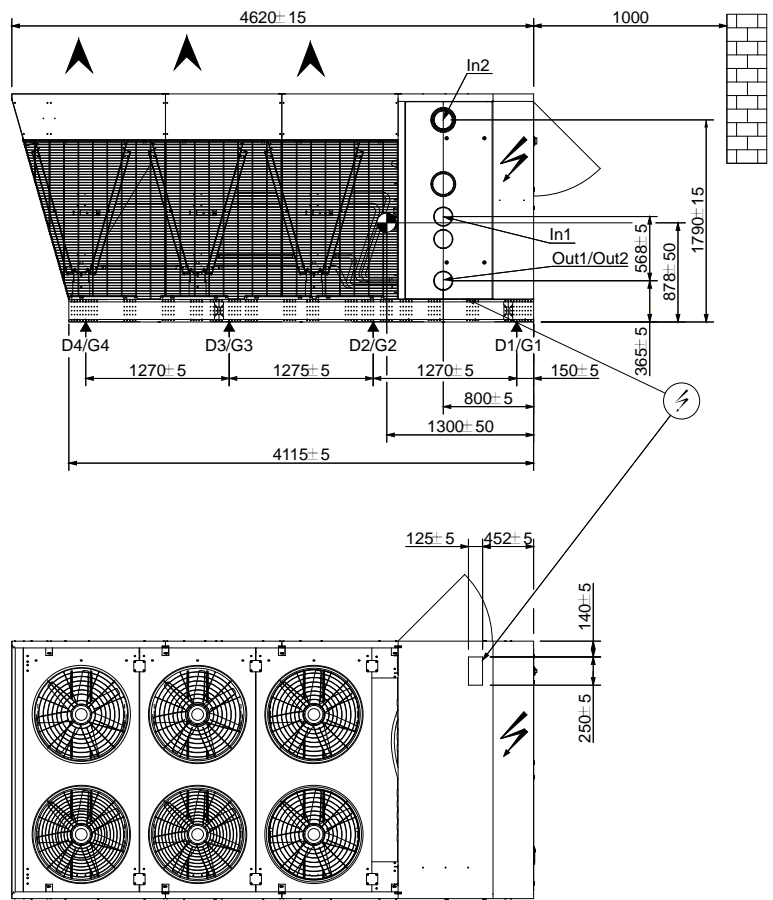
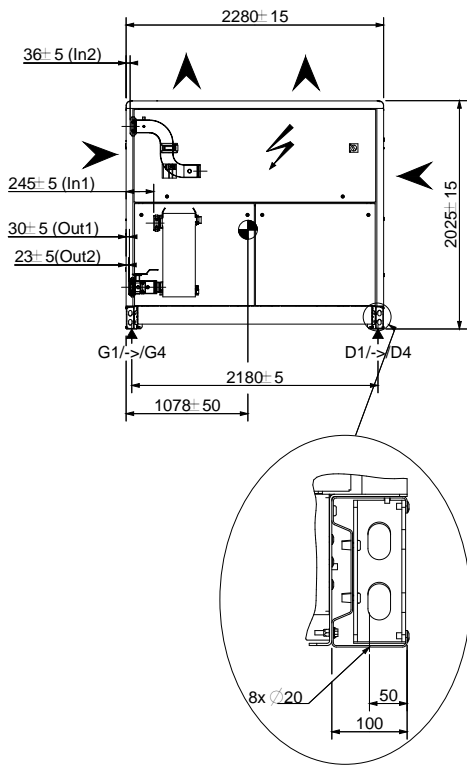

LEGEND:		Ø
	Gravity center	
In 1	Chilled water inlet - Unit without hydraulic module	Ø 4" Victaulic
In 2 :	Chilled water inlet - Unit with hydraulic module	
Out :	Chilled water outlet	

LOAD DITRIBUTION

(Kg - Lennox recommend load distribution as detailed below.)
More detailed load distributions available on page xxx

		G1/D1	G2/D2	G3/D3	G4/D4	G5/G5
NAC 300	Without hydraulic module	350	436	319	223	-
	With high pressure double pump	397	495	374	253	-
NAH 300	Without hydraulic module	442	551	416	282	-
	With high pressure double pump	489	609	460	312	-

**NAC 340 / 380
NAH 340**

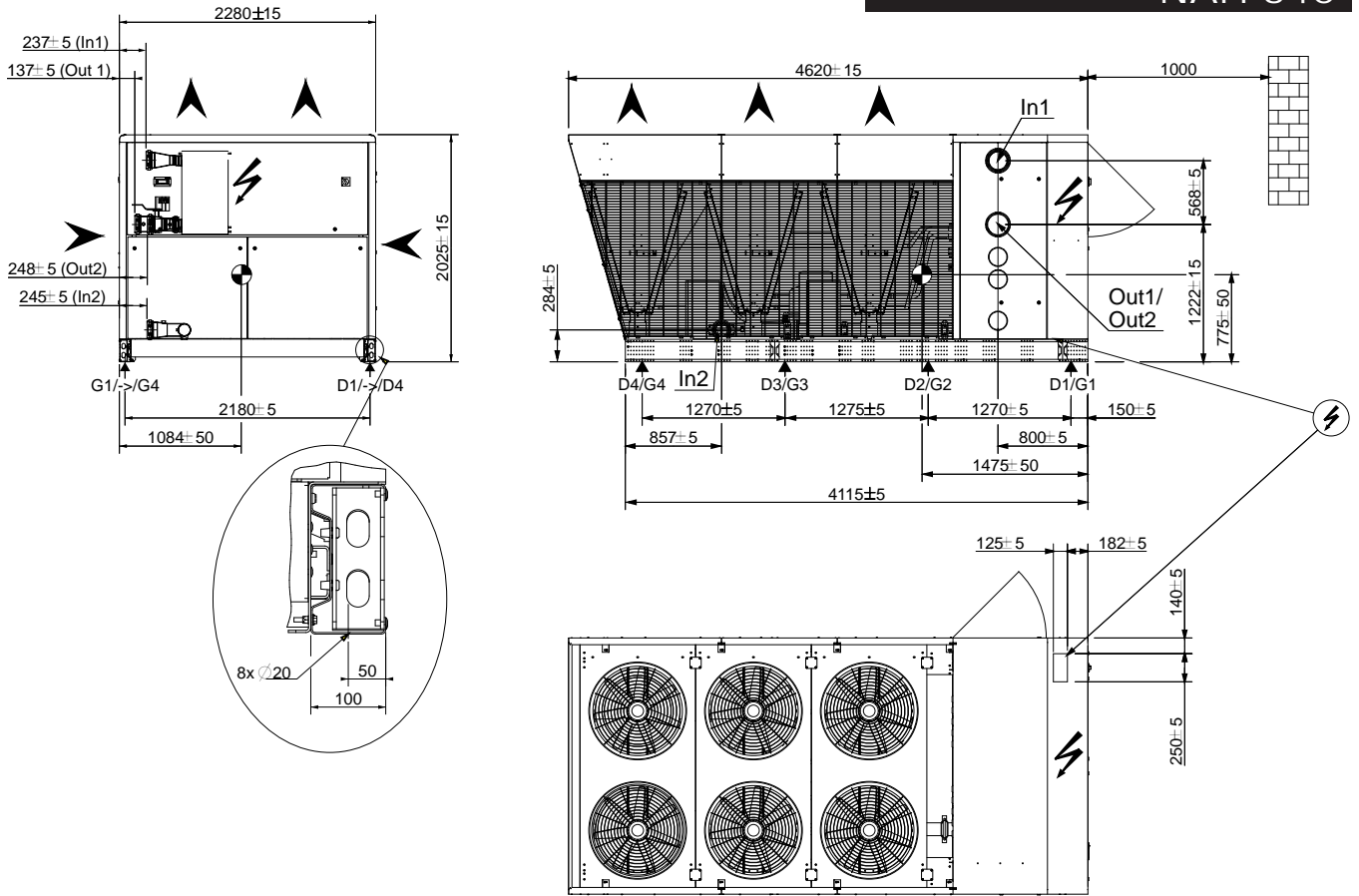

LEGEND:		Ø
	Gravity center	
In 1	Chilled water inlet - Unit without hydraulic module	Ø 5" Victaulic
In 2 :	Chilled water inlet - Unit with all hydraulic module	
Out 1 :	Chilled water outlet - Unit without hydraulic module / with variable water flow hydraulic module (eDrive)	
Out 2 :	Chilled water outlet - Unit with hydraulic module	

LOAD DITRIBUTION

(Kg - Lennox recommend load distribution as detailed below.)
More detailed load distributions available on page xxx

		G1/D1	G2/D2	G3/D3	G4/D4	G5/G5
NAC 340	Without hydraulic module	370	495	381	256	-
	With high pressure double pump	417	557	428	288	-
NAC 380	Without hydraulic module	375	502	386	259	-
	With high pressure double pump	422	564	433	291	-
NAH 340	Without hydraulic module	413	552	424	285	-
	With high pressure double pump	459	614	472	317	-

NAC 420 / 480
NAH 380 / 420 / 480

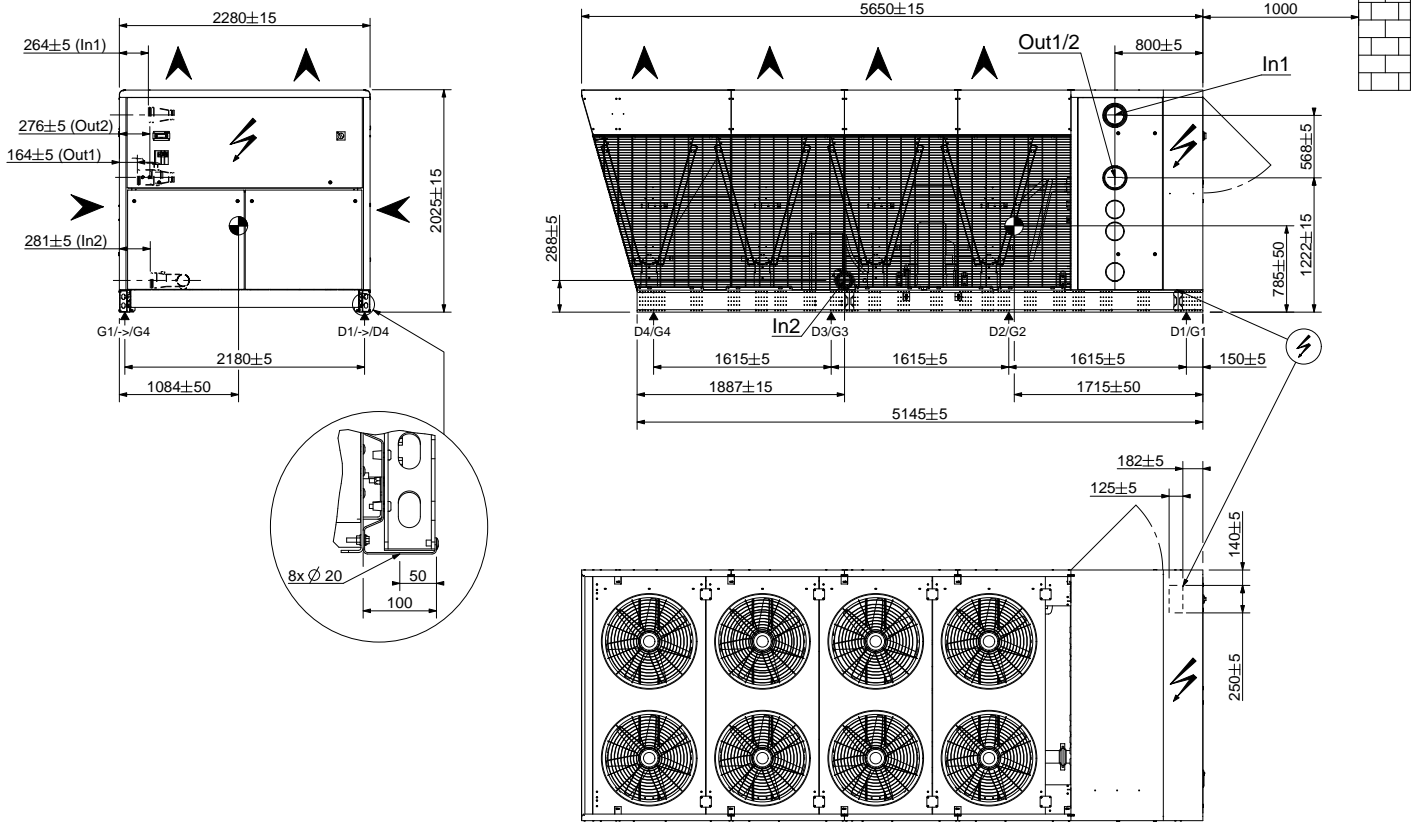

LEGEND:		Ø
	Gravity center	
In 1	Chilled water inlet - Unit without hydraulic module	Ø 5" Victaulic
In 2 :	Chilled water inlet - Unit with all hydraulic module	
Out 1 :	Chilled water outlet - Unit without hydraulic module / with variable water flow hydraulic module (eDrive)	
Out 2 :	Chilled water outlet - Unit with hydraulic module	

LOAD DITRIBUTION

(Kg - Lennox recommend load distribution as detailed below.)
More detailed load distributions available on page xxx

		G1/D1	G2/D2	G3/D3	G4/D4	G5/G5
NAC 420	Without hydraulic module	454	592	445	298	-
	With high pressure double pump	504	657	494	331	-
NAC 480	Without hydraulic module	465	606	455	305	-
	With high pressure double pump	514	670	504	338	-
NAH 380	Without hydraulic module	510	665	500	335	-
	With high pressure double pump	558	772	547	366	-
NAH 420	Without hydraulic module	516	672	506	339	-
	With high pressure double pump	566	737	554	371	-
NAH 480	Without hydraulic module	526	686	516	346	-
	With high pressure double pump	576	751	565	378	-

NAC 540

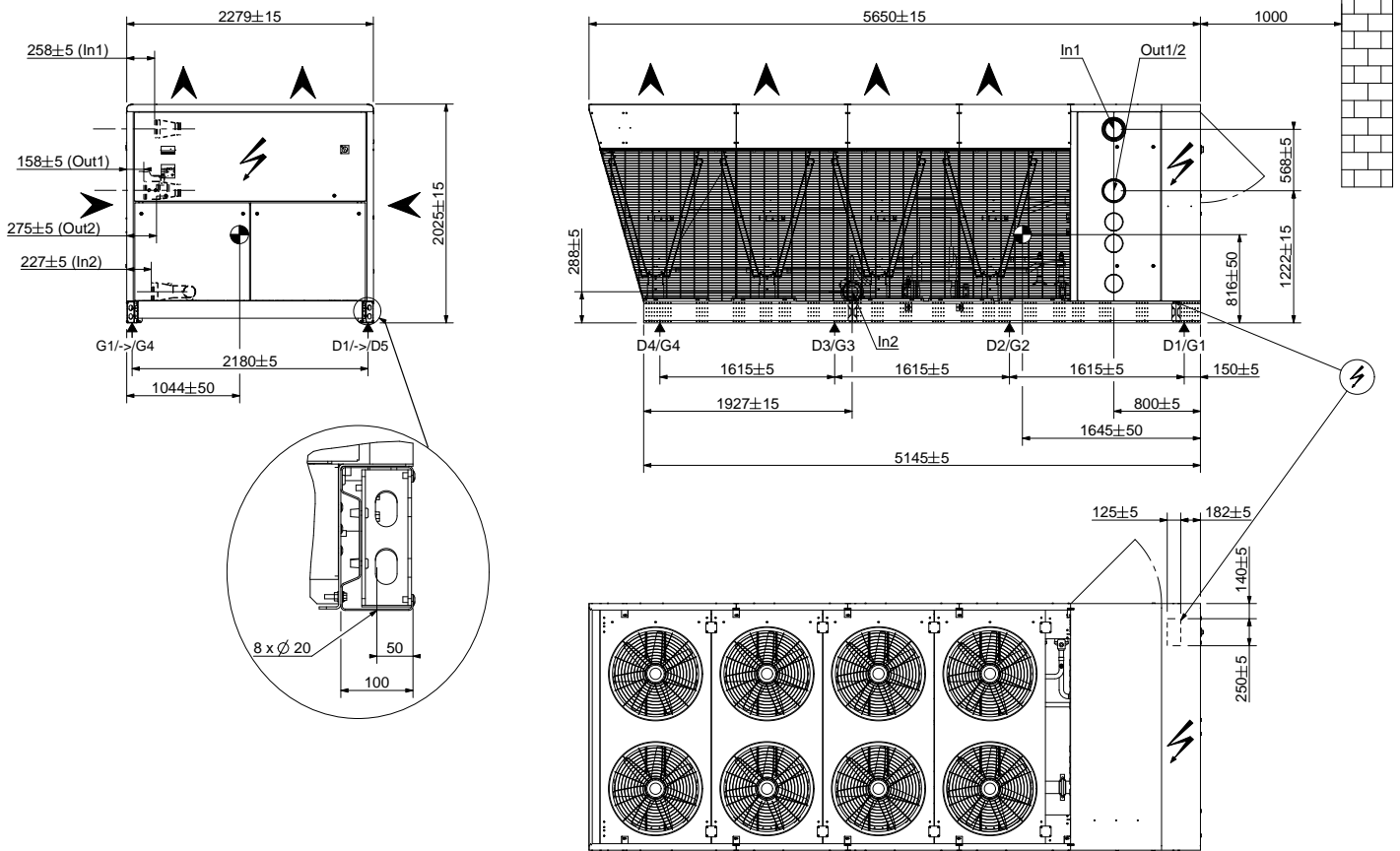

LEGEND:		Ø
	Gravity center	
In 1	Chilled water inlet - Unit without hydraulic module	Ø 6" Victaulic
In 2 :	Chilled water inlet - Unit with all hydraulic module	
Out 1 :	Chilled water outlet - Unit without hydraulic module / with variable water flow hydraulic module (eDrive)	
Out 2 :	Chilled water outlet - Unit with hydraulic module	

LOAD DITRIBUTION

(Kg - Lennox recommend load distribution as detailed below.)
 More detailed load distributions available on page xxx

		G1/D1	G2/D2	G3/D3	G4/D4	G5/G5
NAH 540	Without hydraulic module	481	608	458	309	-
	With high pressure double pump	548	693	523	353	-

NAC 600 / 640

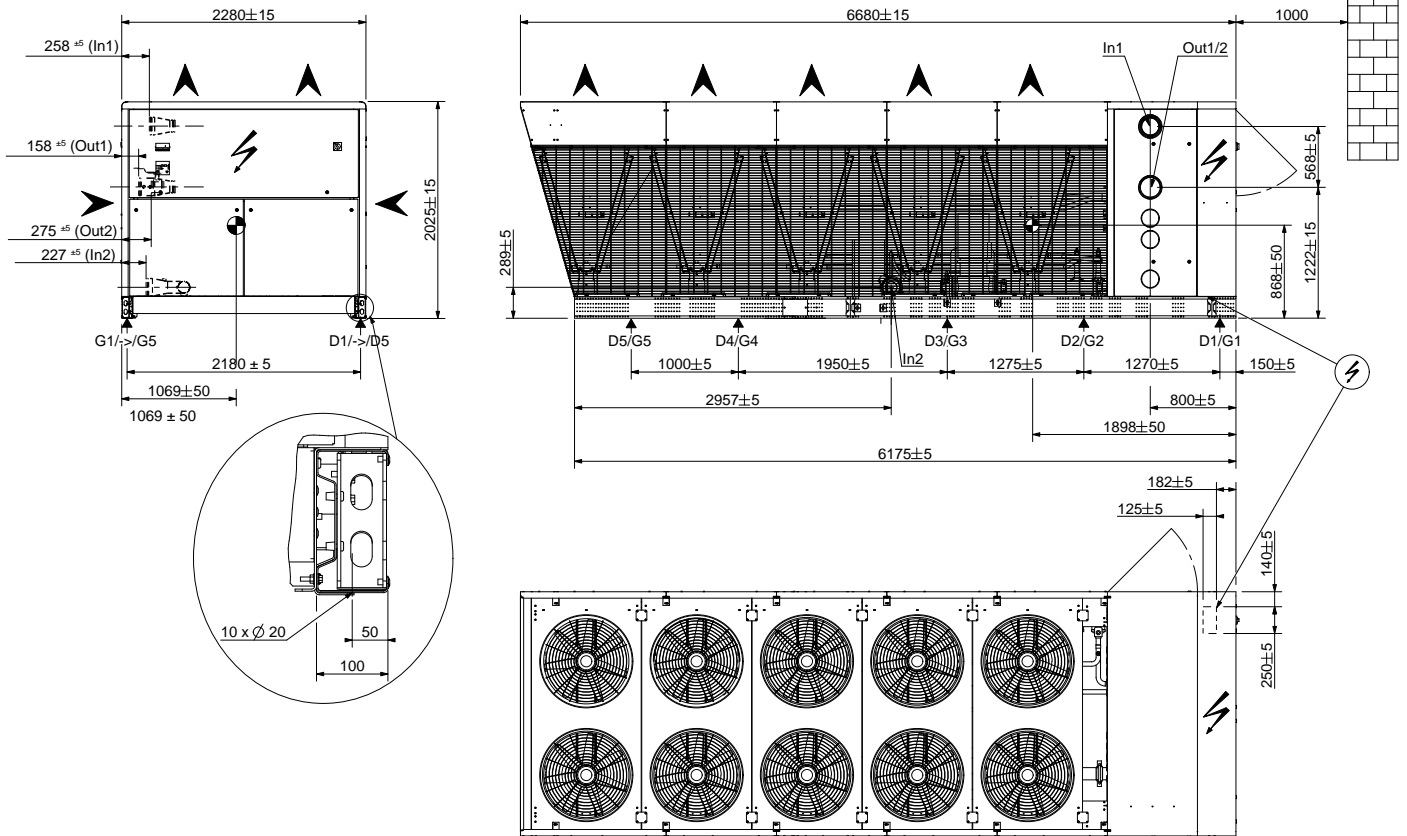

LEGEND:		Ø
	Gravity center	
In 1	Chilled water inlet - Unit without hydraulic module	Ø 6" Victaulic
In 2 :	Chilled water inlet - Unit with all hydraulic module	
Out 1 :	Chilled water outlet - Unit without hydraulic module / with variable water flow hydraulic module (eDrive)	
Out 2 :	Chilled water outlet - Unit with hydraulic module	

LOAD DITRIBUTION

(Kg - Lennox recommends load distribution as detailed below.)
 More detailed load distributions available on page xxx

		G1/D1	G2/D2	G3/D3	G4/D4	G5/G5
NAC 600	Without hydraulic module	424	493	476	369	315
	With high pressure double pump	477	555	535	416	354
NAC 640	Without hydraulic module	426	496	478	371	316
	With high pressure double pump	479	558	538	418	356

NAC 680 / 760

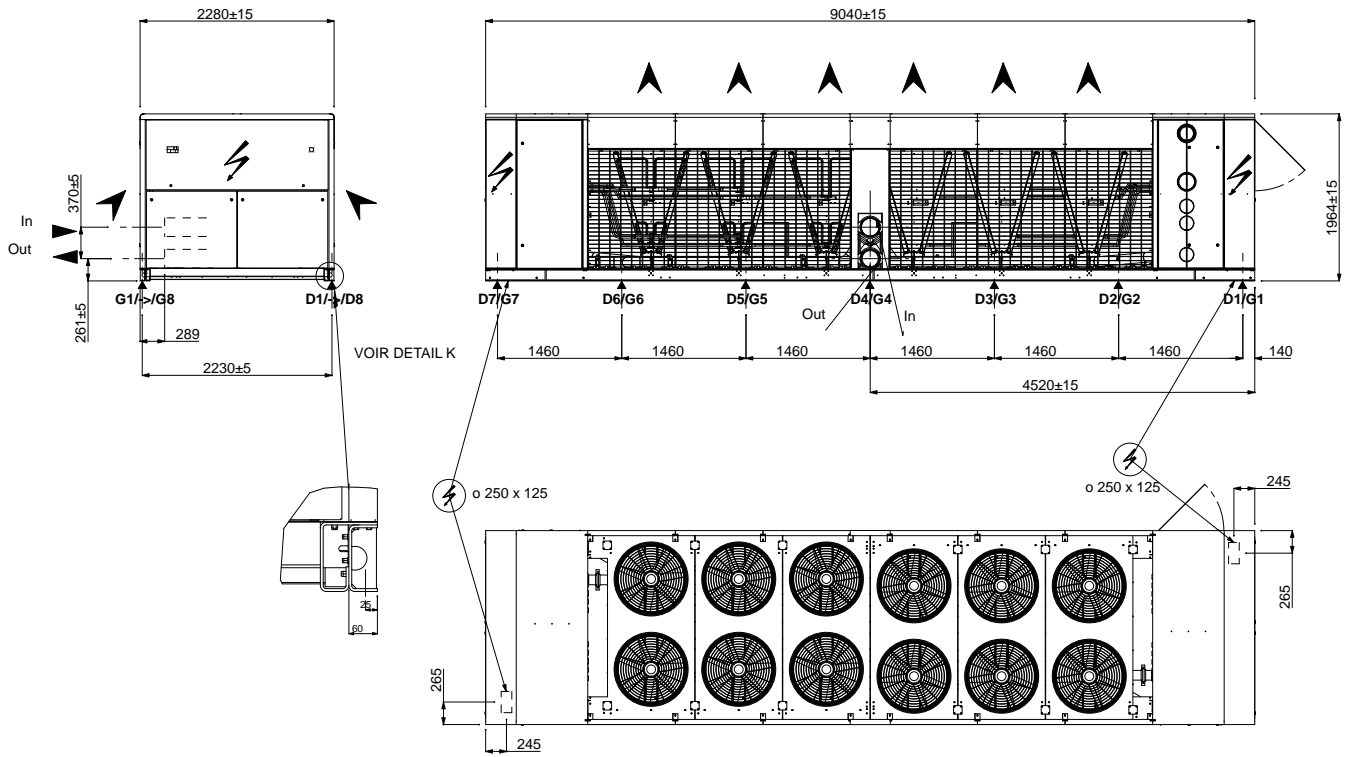

LEGENDE:

- IN** Water inlet
- OUT:** Water outlet

Note: In case of single main power connection (option), main power supply and disconnect switch are located at the right side of the unit.

LOAD DITRIBUTION

(Kg - Operating weights with dual pump hydraulic module)
 Lennox recommends load distribution as detailed below

	G1	G2	G3	G4	G5	G6	G7	D1	D2	D3	D4	D5	D6	D7
NAC 680	480	480	480	480	480	480	480	480	480	480	480	480	480	480
NAC 760	490	490	490	490	490	490	490	490	490	490	490	490	490	490

NAC 840 / 960 / 1080

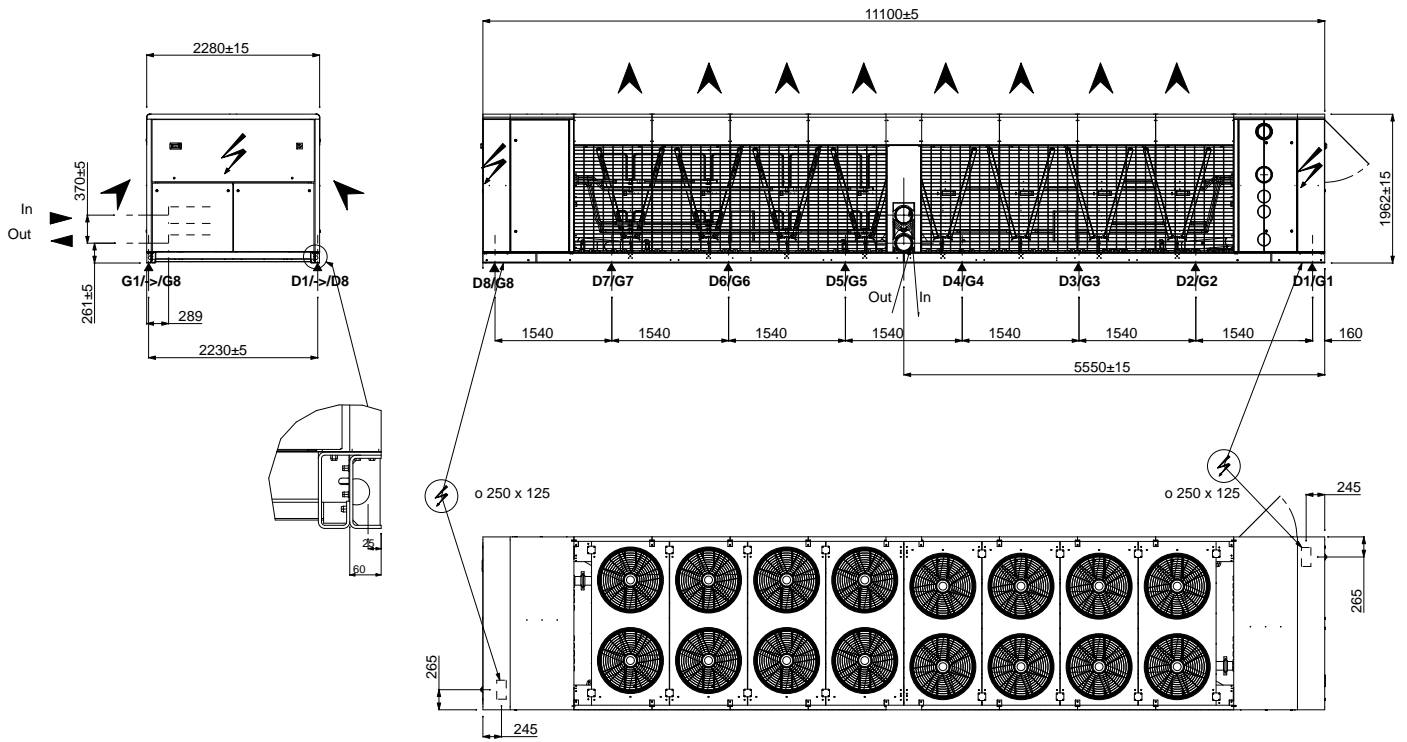

LEGENDE:

IN Water inlet

OUT: Water outlet

Note: In case of single main power connection (option), main power supply and disconnect switch are located at the right side of the unit.

LOAD DITRIBUTION

(Kg - Operating weights with dual pump hydraulic module)

Lennox recommends load distribution as detailed below

	G1	G2	G3	G4	G5	G6	G7	G8	D1	D2	D3	D4	D5	D6	D7	D8
NAC 840	500	500	500	500	500	500	500	500	500	500	500	500	500	500	500	500
NAC 960	510	510	510	510	510	510	510	510	510	510	510	510	510	510	510	510
NAC 1080	510	510	510	510	510	510	510	510	510	510	510	510	510	510	510	510

ANTI-VIBRATION MOUNTS (OPTION)

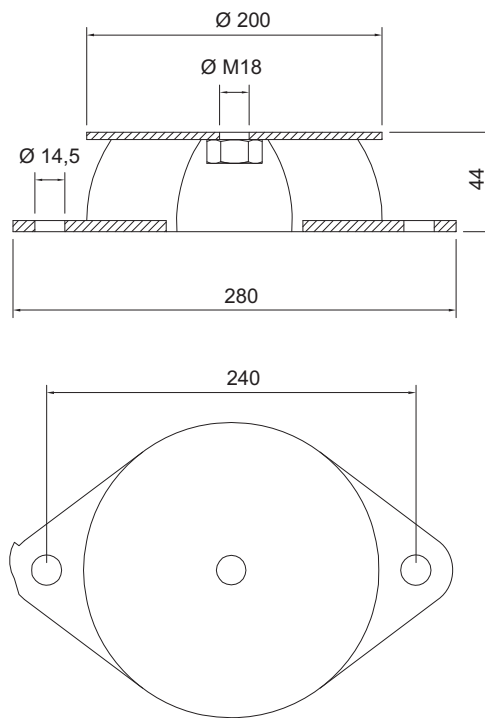

CLEARANCES

Whatever the NEOSYS size, clearances around the unit are the same as indicated below. Overhead obstruction are not permitted

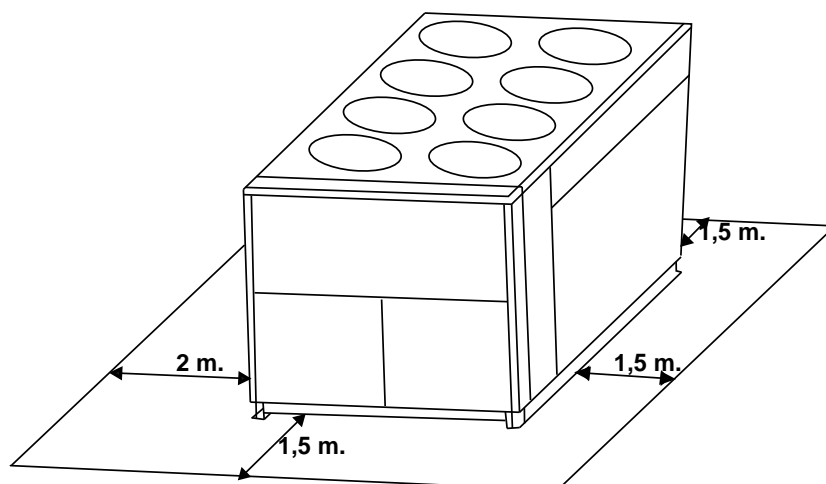

NAC

NAC		200	230	270	300	340	380	420	480
Without hydraulic module									
Operating weight	kg	1983	2011	2278	2676	3003	3045	3580	3661
Shipping weight	kg	1961	1989	2253	2643	2955	2997	3532	3604
With low pressure single pump									
Operating weight	kg	2223	2222	2496	2900	3242	3319	3854	3935
Shipping weight	kg	2188	2187	2459	2854	3176	3253	3788	3861
With low pressure double pump									
Operating weight	kg	2223	2258	2537	2948	3290	3402	3937	4018
Shipping weight	kg	2188	2223	2500	2902	3224	3336	3871	3944
With high pressure single pump									
Operating weight	kg	2200	2264	2538	2944	3286	3328	3866	3947
Shipping weight	kg	2165	2229	2501	2898	3220	3262	3800	3873
With high pressure double pump									
Operating weight	kg	2243	2344	2621	3036	3379	3421	3971	4052
Shipping weight	kg	2208	2309	2584	2990	3313	3355	3905	3978
NAC									
		540	600	640	680	760	840	960	1080
Without hydraulic module									
Operating weight	kg	3712	4152	4175	6770	6854	7981	8141	8229
Shipping weight	kg	3655	4086	4105	6495	6564	7681	7806	7884
With low pressure single pump									
Operating weight	kg	4048	4488	4511	NA				
Shipping weight	kg	3974	4405	4423					
With low pressure double pump									
Operating weight	kg	4155	4595	4618	NA				
Shipping weight	kg	4081	4512	4530					
With high pressure single pump									
Operating weight	kg	4086	4526	4549	NA				
Shipping weight	kg	4012	4443	4461					
With high pressure double pump									
Operating weight	kg	4233	4674	4696	NA				
Shipping weight	kg	4159	4591	4608					

NAH

NAH		200	230	270	300	340	380	420	480
Without hydraulic module									
Operating weight	kg	2176	2175	2906	3380	3349	4020	4066	4148
Shipping weight	kg	2154	2153	2881	3347	3301	3972	4020	4091
With single pump									
Operating weight	kg	2384	2386	3124	3604	3588	4294	4340	4422
Shipping weight	kg	2349	2351	3087	3558	3522	4228	4274	4348
With double pump									
Operating weight	kg	2417	2422	3165	3652	3636	4377	4423	4505
Shipping weight	kg	2382	2387	3128	3606	3570	4311	4357	4431
With high pressure single pump									
Operating weight	kg	2394	2428	3165	3648	3632	4303	4351	4434
Shipping weight	kg	2359	2393	3128	3602	3566	4237	4285	4360
With high pressure double pump									
Operating weight	kg	2436	2508	3249	3740	3725	4395	4457	4539
Shipping weight	kg	2401	2473	3212	3694	3659	4329	4391	4465

LOAD DISTRIBUTION - DETAILED DATA

Lennox recommends load distribution as detailed below

NAC

		G1/D1	G2/D2	G3/D3	G4/D4	G5/G5
NAC 200	Without hydraulic module	350	428	214	0	0
	With low pressure single pump	387	472	236	0	0
	With low pressure double pump	392	480	240	0	0
	With high pressure double pump	388	475	237	0	0
	With high pressure double pump	396	484	242	0	0
NAC 230	Without hydraulic module	355	434	217	0	0
	With low pressure single pump	392	479	240	0	0
	With low pressure double pump	398	487	244	0	0
	With high pressure double pump	400	488	244	0	0
	With high pressure double pump	414	506	253	0	0
NAC 270	Without hydraulic module	402	491	246	0	0
	With low pressure single pump	440	538	269	0	0
	With low pressure double pump	448	547	274	0	0
	With high pressure double pump	448	547	274	0	0
	With high pressure double pump	463	565	283	0	0
NAC 300	Without hydraulic module	350	436	329	223	0
	With low pressure single pump	379	472	357	242	0
	With low pressure double pump	385	480	363	246	0
	With high pressure double pump	385	480	362	245	0
	With high pressure double pump	397	495	374	253	0
NAC 340	Without hydraulic module	370	495	381	256	0
	With low pressure single pump	400	535	411	276	0
	With low pressure double pump	406	542	417	280	0
	With high pressure double pump	405	542	416	280	0
	With high pressure double pump	417	557	428	288	0
NAC 380	Without hydraulic module	375	502	386	259	0
	With low pressure single pump	409	547	421	283	0
	With low pressure double pump	419	561	431	290	0
	With high pressure double pump	410	549	422	283	0
	With high pressure double pump	422	564	433	291	0
NAC 420	Without hydraulic module	454	592	445	298	0
	With low pressure single pump	489	637	479	321	0
	With low pressure double pump	500	651	490	328	0
	With high pressure double pump	491	639	481	322	0
	With high pressure double pump	504	657	494	331	0
NAC 480	Without hydraulic module	465	606	455	305	0
	With low pressure single pump	499	651	489	328	0
	With low pressure double pump	510	665	500	335	0
	With high pressure double pump	501	653	491	329	0
	With high pressure double pump	514	670	504	338	0
NAC 540	Without hydraulic module	481	608	458	309	0
	With low pressure single pump	524	663	500	337	0
	With low pressure double pump	538	680	513	346	0
	With high pressure double pump	529	669	505	340	0
	With high pressure double pump	548	693	523	353	0
NAC 600	Without hydraulic module	424	493	476	369	315
	With low pressure single pump	458	533	514	399	340
	With low pressure double pump	469	546	526	409	348
	With high pressure double pump	462	537	518	402	343
	With high pressure double pump	477	555	535	416	354
NAC 640	Without hydraulic module	426	496	478	371	316
	With low pressure single pump	460	536	517	401	342
	With low pressure double pump	471	548	529	411	350
	With high pressure double pump	464	540	521	404	345
	With high pressure double pump	479	558	538	418	356

LOAD DISTRIBUTION - DETAILED DATA

Lennox recommends load distribution as detailed below

NAH

		G1/D1	G2/D2	G3/D3	G4/D4	G5/G5
NAH 200	Without hydraulic module	384	469	235	0	0
	With low pressure single pump	421	514	257	0	0
	With low pressure double pump	426	521	261	0	0
	With high pressure double pump	422	516	258	0	0
	With high pressure double pump	430	526	263	0	0
NAH 230	Without hydraulic module	384	469	235	0	0
	With low pressure single pump	421	515	257	0	0
	With low pressure double pump	427	522	261	0	0
	With high pressure double pump	428	524	262	0	0
	With high pressure double pump	442	541	270	0	0
NAH 270	Without hydraulic module	369	481	361	242	0
	With low pressure single pump	397	517	388	260	0
	With low pressure double pump	402	523	393	264	0
	With high pressure double pump	402	523	393	264	0
	With high pressure double pump	413	537	404	271	0
NAH 300	Without hydraulic module	442	551	416	282	0
	With low pressure single pump	471	587	443	300	0
	With low pressure double pump	477	595	449	304	0
	With high pressure double pump	477	594	449	304	0
	With high pressure double pump	489	609	460	312	0
NAH 340	Without hydraulic module	413	552	424	285	0
	With low pressure single pump	442	592	455	305	0
	With low pressure double pump	448	600	461	310	0
	With high pressure double pump	448	599	460	309	0
	With high pressure double pump	459	614	472	317	0
NAH 380	Without hydraulic module	510	665	500	335	0
	With low pressure single pump	545	710	534	358	0
	With low pressure double pump	555	724	544	365	0
	With high pressure double pump	546	712	535	359	0
	With high pressure double pump	558	727	547	366	0
NAH 420	Without hydraulic module	516	672	506	339	0
	With low pressure single pump	551	718	540	362	0
	With low pressure double pump	561	731	550	369	0
	With high pressure double pump	552	720	541	363	0
	With high pressure double pump	566	737	554	371	0
NAH 480	Without hydraulic module	526	686	516	346	0
	With low pressure single pump	561	731	550	369	0
	With low pressure double pump	572	745	560	375	0
	With high pressure double pump	563	733	551	369	0
	With high pressure double pump	576	751	565	378	0

lennoxemea.com

Due to LENNOX EMEA ongoing commitment to quality, the specifications, ratings and dimensions are subject to change without notice and without incurring liability.
Improper installation, adjustment, alteration, service or maintenance can cause property damage or personal injury.
Installation and service must be performed by a qualified installer and servicing agency.



NEOSYS-AGU-1801-E

