

APPLICATION GUIDE

HYDROLEAN

SWC - SWH - SWR

Water cooled chillers
Heat pumps

20 > 165 kW



HYDROLEAN-AGU-1308-E

HYDROLEAN

APPLICATION GUIDE

Ref : HYDROLEAN-AGU-1308-E

1. FEATURES AND BENEFITS	
Model number description - General description	2
Description of components	3
Options and Accessories	4
2. TECHNICAL DATA	
General data	6
Pressure drops	12
Seasonal efficiency (ESEER)	14
Correction tables	14
Acoustic data	15
Operating limits	16
3. PERFORMANCES	
Performances data	18
4. ELECTRICAL DATA	
Electrical Tables	26
5. PRINCIPLE SKETCHES	
Hydraulic data	27
Refrigerant drawings	28
7. DIMENSIONS AND WEIGHTS	
Unit general arrangement drawings	34



www.eurovent-certification.com
www.certiflash.com

Our products comply with the European standards.



Product designed and manufactured under quality management systems certified ISO 9001

All the technical and technological information contained in this manual, including any drawing and technical descriptions provided by us, remain the property of Lennox and must not be utilised (except in operation of this product), reproduced, issued to or made available to third parties without the prior written agreement of Lennox.

MODEL NUMBER DESCRIPTION

EXAMPLE : SWC 025 S M 1 M

S	Small
W	Water
C	C : Cooling
	H : Heat pump
	R : Remote condenser
025	Size, approximate cooling capacity at Eurovent conditions
S	S : Single Circuit
	D : Dual Circuit
N	Non ducted
M	R410A
1	Revision number
M	400V/3/50Hz

The HYDROLEAN liquid chillers perfectly combine with our complete range of HVAC system.

The manufacturing of HYDROLEAN chillers complies with the European standards and answers to ISO 9001 control quality system of our company.

In order to meet the final conformity of finished product with the customers' order and the perfect refrigeration and electrical operation of the unit as well, the HYDROLEAN chillers are systematically tested in the test station before sending.

With low dimensions and quiet operation, the HYDROLEAN chillers make use of the finest in technology to satisfy the strictest reliability and safety requirements.

The HYDROLEAN range has been specially designed and developed for operation with refrigerant R410A refrigerant, thus taking account of environment-related factors. Design takes care of noise levels, pollution affecting the ozone layer, energy consumption and recycling of materials used.

The HYDROLEAN range benefits from the latest technological innovations such as Scroll compressors, microprocessor control and brazed plate exchanger. The HYDROLEAN liquid chiller is compact and easy to install in small spaces. Since it is fully enclosed, it does not need a dedicated machine room. One unit can be placed on top of another for better use of space, if required (up to size 080).

The original design of this range makes service easy : no tools are required to remove panels and optimal access to the various components.

The HYDROLEAN range is available in three versions:

- Cooling only : SWC
- Heat pump : SWH
- Remote condenser : SWR

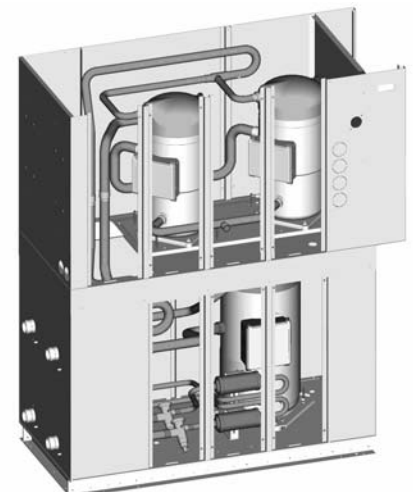
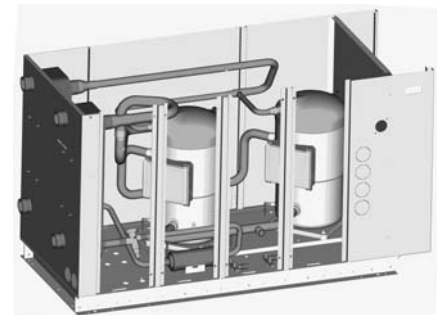
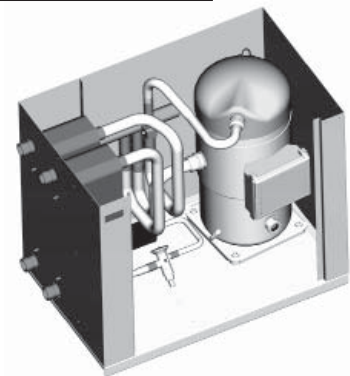

CONSTRUCTION

FRAME AND CASING

Frame and casing made of galvanised sheet metal steel. Painted in over-baked epoxy powder paint in white color (RAL 9002).

Removable side and rear panels.

Front access via dismantable doors.

Unit lifting and handling via the base frame.

The HYDROLEAN range is made up on the basis of three cases:

- A box from 025 to 035,
- B box from 050 to 080
- C box from 100 to 160.

COMPRESSOR

Scroll compressors are comprised of two identical scrolls mated together to form concentric spiral shapes. Note the absence of seals between the two scrolls. The Scroll design maintains consistent volumetric output even without seals. Absence of dead space, resulting in a volumetric efficiency approaching 100% for the compressor. Fewer moving parts, leading to lower failure rate. The scroll compressors are simple, efficient, durable and quiet. When used in tandems the compressing unit is assembled on an independent plate separated of the frame by rubber pads. The HYDROLEAN range is made of :

- one compressor from size 025 to 035,
- two compressors from size 050 to 080,
- three compressors from size 100 to 160.

Crankcase heater.

Direct on line start.

EVAPORATOR

AISI 304 stainless steel plate copper brazed heat exchanger.

Thermal insulation by top grade plastic foam and steam resistant glue.

Paddle flow switch supplied loose on evaporator.

Threaded male connection.

Water filter (option).

CONDENSER (EXCEPT SWR REMOTE CONDENSER)

AISI 304 stainless steel plate copper brazed heat exchanger.

Threaded male connection.

Water filter (option).

REFRIGERANT CIRCUIT

It is composed of the following main components :

SWC version (cooling only) :

- R410A refrigerant,
- Brazed filter dryer,
- Thermostatic expansion valve,
- HP and LP pressure switches.

SWH version (heat pump):

- R410A refrigerant,
- Brazed filter dryer,
- Thermostatic expansion valve,
- HP and LP pressure switches and 4 way valve.

SWR version (remote condenser) :

- Refrigerant circuit is delivered with pressurized nitrogen
- Replaceable cartridge filter dryer,
- Suction and discharge valves by circuit.
- The main components of the refrigerant circuit are brazed.

CONTROL AND POWER CIRCUIT CONTROL BOX

Control and protection panel according to EN 60 204-1

The electrical box is accessible via a dismantable door.

It includes a main on/off switch and circuit breakers, contactors for the compressors.

The CLIMATIC 40 controller is an electronic device allowing the following operations:

- Unit ON/OFF.
- Select system operating mode.
- Setpoint adjustment.
- Alarm signal relay.
- Display temperature, status of unit and pending alarms.
- Programming of time bands.
- BMS communications (option).
- Possibility of remote ON/OFF (option).

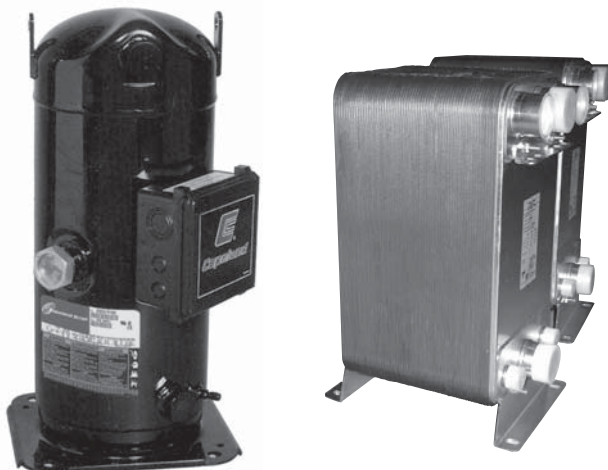

AVAILABLE OPTIONS

	SWC	SWH	SWR
HP / LP pressure gauge	x	x	x
Electrical equipment of outside fan 1, 2, 3 or 4	x	x	x
Electrical equipment of outside pump 1	x	x	x
Electrical equipment of outside pump 2	x	x	NA
ModBus communication interface RS485	x	x	x
Remote display	x	x	x
Dynamic setpoint	x	x	x
Hot water control	x	NA	NA
Low Noise with compressor jackets	x	x	x
Anti-vibration mounts (rubber type)	x	x	x
Low water leaving temperature operation	x	NA	x
Pressure regulated water valve	x	NA	NA
Water filters for evaporator	x	x	x
Water filters for condenser	x	x	NA
Compressor acoustic jacket	x	x	x

HP&LP pressure gauges

Liquid filled gauges that measure the evaporating Low pressure (LP) and condensing high pressure (HP) on each refrigerant circuit. Gauges are «glycerin» filled to damp gas pulsation and are mounted externally. The gauges are compound gauges that display the saturated refrigerant temperature for the refrigerant R410A.

Anti-vibration rubber mounts

Rubber reduce the transmission of vibration to the ground and the general sound level. They are fixed under the unit at the points specified by our technical drawing. Supplied loose.

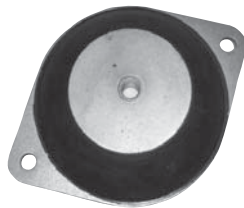
Low noise with compressor jacket

This option consists of a high efficiency jacket especially designed for the scroll compressors. It allows an increased output of the acoustic performances and gives good access to the compressors for maintenance.

Water filter

Water strainers is to be installed upstream on the water inlet to protect the evaporator and condenser from any possible impurities (1 mm efficiency). Supplied loose.

Low water leaving temperature operation

Low water leaving evaporator temperature option is required for water outlet temperatures below 0 °C. This option includes a specific thermostatic expansion, the replacement of the low pressure switch and the intensification of evaporator insulation.

Hot water control

This function allows to regulate the hot water leaving temperature of the condenser, only frost protection remains active on the evaporator.

Pressure regulated water valve

The valve with pressure-controller water allows to control the flow of water to the condenser and to maintain a pressure of condensation minimum. This option is compulsory if the outlet water temperature of the condenser is lower than 20°C. Supplied loose.

Electrical equipment of outside first fan

Electrical protection and control of an external fan via pressure switch.

Electrical equipment of outside second fan

Electrical protection and control of 2 external fans via pressure switch.

Electrical equipment of outside third fan

Electrical protection and control of 3 external fans via pressure switch.

Electrical equipment of outside fourth fan

Electrical protection and control of 4 external fans via pressure switch.

Electrical equipment of outside pump 1

Electrical protection and control of a single pump for evaporator.

Electrical equipment of outside pump 2

Electrical protection of a single pump for the condenser.

Modbus communication interface RS485



Communication card using Modbus protocol. Communication interface with building management system.

Remote display

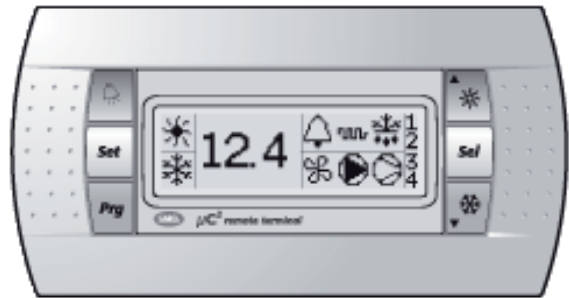

The remote display DC41 controls and shows the unit's operation. It can be installed up to 50 m from the unit. Supplied loose.

Dynamic setpoint

It changes cooling and heating setpoints according to ambient temperature (an extra sensor must be installed).

Cooling only

HYDROLEAN		025	035	050	070	080	100	120	135	160
Cooling mode ⁽¹⁾										
Cooling capacity	kW	25,8	37,9	50,8	71,9	83,6	95,7	117,5	132,7	156,4
Power input		5,9	8,9	11,9	18,5	22,2	22,5	29,1	31,7	39,5
EER		4,37	4,25	4,26	3,89	3,77	4,25	4,04	4,19	3,96
ESEER		4,78	4,59	5,40	5,13	4,80	5,68	5,55	5,33	5,25
EUROVENT energy efficiency class		C	C	C	D	D	C	D	D	D
Heating mode										
Heating capacity	kW	NA								
Power input		NA								
COP		NA								
EUROVENT energy efficiency class		NA								
Compressor						Scroll				
Number of compressor		1	1	2	2	2	3	3	3	3
Number of capacity steps		1	1	2	2	2	3	3	3	3
Oil charge per compressor	l	3,25	3,25	3,25+ 3,25	3,25+ 3,25	3,38+ 3,38	3,25+ 3,25+ 3,38	3,25+ 3,25+ 3,38	3,25 +3,25+ 4,67	3,38+ 3,38+ 6,8
Oil type		MOBIL EAL Arctic 22CC or ICI EMKARATE RL32CF								
Refrigerant						R410A				
Type of expansion valve		Thermostatic expansion valve								
Number of circuit		1	1	1	1	1	2	2	2	2
Charge per circuit	kg	3,5	4,5	6,6	7	7,2	6,3/5,7	6,4/5,7	7,6/7,5	7,5/8,0
Evaporator						AISI 304 stainless steel plate brazed with copper heat exchanger				
Water flow ⁽¹⁾	m ³ /h	4,4	6,5	8,6	12,6	14,4	16,5	20,6	22,7	28,0
Water volume	l	3,0	4,0	5,2	5,7	5,7	10,0	10,0	12,8	12,8
Pressure drop ⁽¹⁾	kPa	16,5	20,5	25,4	41,4	52,9	24,7	34,5	31,6	41,7
Maxi. water operating pressure	kPa	600	600	600	600	600	600	600	600	600
Condenser						AISI 304 stainless steel plate brazed with copper heat exchanger				
Water flow ⁽¹⁾	m ³ /h	5,3	7,8	10,4	15,0	17,0	19,5	24,9	27,8	32,8
Water volume	l	3,0	4,0	5,2	5,7	5,7	10,0	10,0	12,8	12,8
Pressure drop ⁽¹⁾	kPa	21,6	26,9	33,6	56,9	71,4	30,3	48,1	42,7	58,6
Water operating pressure	kPa	600	600	600	600	600	600	600	600	600
Hydraulic connections						Threaded male				
Water inlet / outlet		1"1/2 / DN40					2"/DN50			

(1) All data are at Eurovent condition.

Cooling mode :

Water temperature = 12/7 °C
Condenser water 30/35 °C

Heating mode :

Water temperature = 40/45 °C
Evaporator water inlet 30/35 °C
Evaporator water outlet temperature calculated with the same water flow as in cooling mode

(2) At maximum compressor load.

HYDROLEAN		025	035	050	070	080	100	120	135	160
Acoustic										
Global sound power level	dB(A)	69,0	71,0	72,0	74,0	75,0	75,0	76,1	78,8	81,2
Global sound power level with acoustic jacket (option)		60,6	61,5	63,6	64,5	64,9	65,9	66,4	70,7	72,5
Sound pressure level 10 meters from the unit		41,3	43,3	44,3	46,3	47,5	47,4	48,5	51,2	53,7
Sound pressure level 10 meters from the unit with acoustic jacket (option)		31,2	32,6	34,2	35,6	36,4	36,8	37,7	41,6	44,1
Electrical data 400V/III/50Hz										
Nominal current ⁽¹⁾	A	11,1	15,3	22,2	30,9	41,0	42,8	51,6	54,8	71,4
Start-up current ⁽²⁾		111,2	140,2	127,8	164,7	204,3	207,8	223,6	274,6	332,3
Maximum current ⁽²⁾		16,8	24,6	33,4	49,2	60,3	63,8	79,6	86,0	105,3
Maximum power	kW	10,3	14,8	20,5	29,6	33,9	37,6	46,7	52,3	61,7
Short circuit unit capacity	kA	10,0	10,0	10,0	10,0	10,0	10,0	10,0	10,0	10,0
Max supply cable size (with plug)	mm ²	6	16	35	35	95	95	95	95	95
Dimensions										
Length	mm	802	802	1470	1470	1470	1470	1470	1470	1470
Width	mm	502	502	645	645	645	645	645	645	645
Height	mm	815	815	854	854	854	1705	1705	1705	1705
Footprint	m ²	0,4	0,4	0,9	0,9	0,9	0,9	0,9	0,9	0,9
Shipping Weight	kg	166	236	316	360	377	574	585	698	719
Operating Weight	kg	176	249	333	378	396	606	617	739	760
Construction										
Frame	Galvanised steel frame									
Casing	Galvanised steel									
Painting	Polyester - RAL 9002									
Insulation class	M1									

(1) All data are at Eurovent condition.

Cooling mode :

Water temperature = 12/7 °C
Condenser water 30/35 °C

Heating mode :

Water temperature = 40/45 °C
Evaporator water inlet 30/35 °C
Evaporator water outlet temperature calculated with the same water flow as in cooling mode

(2) At maximum compressor load.

Heat pump

HYDROLEAN		025	035	050	070	080	100	120	135	160
Cooling mode ⁽¹⁾										
Cooling capacity	kW	25,5	37,6	50,3	71,6	81,8	95	116,5	131,9	155,8
Power input		6,0	9,1	12,1	18,7	21,0	22,8	29,5	32,1	39,7
EER		4,25	4,14	4,15	3,83	3,90	4,17	3,95	4,11	3,92
ESEER		4,57	4,48	5,48	4,72	4,62	5,26	5,33	5,14	5,12
EUROVENT energy efficiency class		C	D	D	E	D	D	D	D	D
Heating mode										
Heating capacity	kW	28,0	41,4	55,5	79,6	91,7	104,6	129,30	145,10	173,00
Power input		7,5	11,1	15,1	22,7	25,3	28,3	35,80	39,20	48,00
COP		3,73	3,73	3,68	3,51	3,62	3,70	3,61	3,70	3,60
EUROVENT energy efficiency class		D	D	D	E	D	D	D	D	D
Compressor Scroll										
Number of compressor		1	1	2	2	2	3	3	3	3
Number of capacity steps		1	1	2	2	2	3	3	3	3
Oil charge per compressor	l	3,25	3,25	3,25 + 3,25	3,25 + 3,25	3,38 + 3,38	3,25 + 3,25 + 3,38	3,25 + 3,25 + 3,38	3,25 + 3,25 + 4,67	3,38 + 3,38 + 6,8
Oil type		MOBIL EAL Arctic 22CC or ICI EMKARATE RL32CF								
Refrigerant R410A										
Type of expansion valve		Thermostatic expansion valve								
Number of circuit		1	1	1	1	1	2	2	2	2
Charge per circuit	kg	3,5	4,5	6,9	7,4	7,6	6,5/5,8	6,5/5,8	7,8/7,7	7,7/8,2
Evaporator AISI 304 stainless steel plate brazed with copper heat exchanger										
Water flow ⁽¹⁾	m ³ /h	4,4	6,5	8,9	12,5	14,0	16,6	19,8	22,7	27,2
Water volume	l	3,0	4,0	5,2	5,7	5,7	10,0	10,0	12,8	12,8
Pressure drop ⁽¹⁾	kPa	13,0	17,6	23,5	40,5	50,5	22,6	31,3	29,0	40,9
Maxi. water operating pressure	kPa	600	600	600	600	600	600	600	600	600
Condenser AISI 304 stainless steel plate brazed with copper heat exchanger										
Water flow ⁽¹⁾	m ³ /h	5,1	7,9	10,4	15,3	17,1	19,5	24,1	26,9	32,8
Water volume	l	3,0	4,0	5,2	5,7	5,7	10,0	10,0	12,8	12,8
Pressure drop ⁽¹⁾	kPa	17,6	25,0	31,3	59,0	73,6	30,3	45,3	39,8	58,6
Water operating pressure	kPa	600	600	600	600	600	600	600	600	600
Hydraulic connections Threaded male										
Water inlet / outlet		1"1/2 / DN40					2"/DN50			

(1) All data are at Eurovent condition.

Cooling mode :

Water temperature = 12/7 °C
 Condenser water 30/35 °C

Heating mode :

Water temperature = 40/45 °C
 Evaporator water inlet 30/35 °C
 Evaporator water outlet temperature calculated with the same water flow as in cooling mode

(2) At maximum compressor load.

SWH

Heat pump

HYDROLEAN		025	035	050	070	080	100	120	135	160
Acoustic										
Global sound power level	dB(A)	69,0	71,0	72,0	74,0	75,0	75,0	76,1	78,8	81,2
Global sound power level with acoustic jacket (option)		60,6	61,5	63,6	64,5	64,9	65,9	66,4	70,7	72,5
Sound pressure level 10 meters from the unit		41,3	43,3	44,3	46,3	47,5	47,4	48,5	51,2	53,7
Sound pressure level 10 meters from the unit with acoustic jacket in option		31,2	32,6	34,2	35,6	36,4	36,8	37,7	41,6	44,1
Electrical data 400V/III/50Hz										
Nominal current - Cooling mode ⁽¹⁾	A	11,2	15,5	22,5	31,1	41,2	43,4	52,2	55,4	71,8
Nominal current - Heating mode ⁽¹⁾		12,8	18,1	25,5	36,4	47,0	49,3	60,2	64,1	81,6
Start-up current ⁽²⁾		111,2	140,2	127,8	164,7	204,3	207,8	223,6	274,6	332,3
Maximum current ⁽²⁾		16,8	24,6	33,4	49,2	60,3	63,8	79,6	86,0	105,3
Maximum power	kW	10,3	14,8	20,5	29,6	33,9	37,6	46,7	52,3	61,7
Short circuit unit capacity	kA	10,0	10,0	10,0	10,0	10,0	10,0	10,0	10,0	10,0
Max supply cable size (with plug)	mm ²	6	16	35	35	95	95	95	95	95
Dimensions										
Length	mm	802	802	1470	1470	1470	1470	1470	1470	1470
Width	mm	502	502	645	645	645	645	645	645	645
Height	mm	815	815	854	854	854	1705	1705	1705	1705
Footprint	m ²	0,4	0,4	0,9	0,9	0,9	0,9	0,9	0,9	0,9
Shipping Weight	kg	168	238	321	366	385	582	593	706	729
Operating Weight	kg	178	251	338	385	404	614	625	747	771
Construction										
Frame	Galvanised steel frame									
Casing	Galvanised steel									
Painting	Polyester - RAL 9002									
Insulation class	M1									

(1) All data are at Eurovent condition.

Cooling mode :

Water temperature = 12/7 °C

Condenser water 30/35 °C

Heating mode :

Water temperature = 40/45 °C

Evaporator water inlet 30/35 °C

Evaporator water outlet temperature calculated with the same water flow as in cooling mode

(2) At maximum compressor load.

Unit with remote condenser

HYDROLEAN		025	035	050	070	080	100	120	135	160
Cooling mode ⁽¹⁾										
Cooling capacity	kW	23,9	35,3	47,3	68,2	80,1	89,4	110,9	124,2	148,2
Power input		6,8	10,1	13,7	20,5	24,7	25,4	32,3	35,9	43,7
EER		3,51	3,50	3,45	3,33	3,24	3,52	3,43	3,46	3,39
Heating mode										
Heating capacity	kW	NA								
Power input		NA								
COP		NA								
EUROVENT energy efficiency class		NA								
Compressor						Scroll				
Number of compressor		1	1	2	2	2	3	3	3	3
Number of capacity steps		1	1	2	2	2	3	3	3	3
Oil charge per compressor	l	3.25	3.25	3.25 +3.25	3.25 +3.25	3.38 +3.38	3.25 + 3.25 + 3.38	3.25 + 3.25 +3.38	3.25 + 3.25 + 4.67	3.38 + 3.38 + 6.8
Oil type		MOBIL EAL Arctic 22CC or ICI EMKARATE RL32CF								
Refrigerant						R410A				
Type of expansion valve		Thermostatic expansion valve								
Number of circuit		1	1	1	1	1	2	2	2	2
Charge per circuit	kg									
Evaporator						AISI 304 stainless steel plate brazed with copper heat exchanger				
Water flow ⁽¹⁾	m ³ /h	4,1	6,1	8,2	11,8	13,8	15,4	19,1	21,4	25,6
Water volume	l	3,0	4,0	5,2	5,7	5,7	10,0	10,0	12,8	12,8
Pressure drop ⁽¹⁾	kPa	12,0	16,0	20,0	37,0	48,3	20,0	29,3	25,8	36,3
Maxi. water operating pressure	kPa	600	600	600	600	600	600	600	600	600
Refrigerant connections										
Discharge line Circuit 1		7/8"	7/8"	1"1/8"	1"1/8"	1"3/8"	1"1/8"	1"1/8"	1"1/8"	1"3/8"
Discharge line Circuit 2		-	-	-	-	-	7/8"	7/8"	1"1/8"	1"1/8"
Liquid line Circuit 1		5/8"	5/8"	7/8"	7/8"	7/8"	7/8"	7/8"	7/8"	7/8"
Liquid line Circuit 2		-	-	-	-	-	5/8"	5/8"	7/8"	7/8"
Hydraulic connections						Threaded male				
Water inlet / outlet		1"1/2 / DN40					2"/DN50			

(1) All data are at Eurovent condition.

Cooling mode :

Water temperature = 12/7 °C

Condensing temperature = 45 °C

(2) At maximum compressor load.

SWR

Unit with remote condenser

HYDROLEAN		025	035	050	070	080	100	120	135	160
Acoustic										
Global sound power level	dB(A)	69,0	71,0	72,0	74,0	75,0	75,0	76,1	78,8	81,2
Global sound power level with acoustic jacket (option)		60,6	61,5	63,6	64,5	64,9	65,9	66,4	70,7	72,5
Sound pressure level 10 meters from the unit		41,3	43,3	44,3	46,3	47,5	47,4	48,5	51,2	53,7
Sound pressure level 10 meters from the unit with accoustic jacket in option		31,2	32,6	34,2	35,6	36,4	36,8	37,7	41,6	44,1
Electrical data 400V/III/50Hz										
Nominal current - Cooling mode ⁽¹⁾	A	12,0	16,8	24,0	33,5	43,5	46,0	55,6	59,6	76,1
Start-up current ⁽²⁾		111,2	140,2	127,8	164,7	204,3	207,8	223,6	274,6	332,3
Maximum current ⁽²⁾		16,8	24,6	33,4	49,2	60,3	63,8	79,6	86,0	105,3
Maximum power	kW	10,3	14,8	20,5	29,6	33,9	37,6	46,7	52,3	61,7
Short circuit unit capacity	kA	10,0	10,0	10,0	10,0	10,0	10,0	10,0	10,0	10,0
Max supply cable size (with plug)	mm ²	6	16	35	35	95	95	95	95	95
Dimensions										
Length	mm	802	802	1470	1470	1470	1470	1470	1470	1470
Width	mm	502	502	645	645	645	645	645	645	645
Height	mm	815	815	854	854	854	1705	1705	1705	1705
Footprint	m ²	0,4	0,4	0,9	0,9	0,9	0,9	0,9	0,9	0,9
Shipping Weight	kg	148	187	281	301	308	477	488	572	593
Operating Weight	kg	155	196	293	314	321	499	510	600	621
Construction										
Frame	Galvanised steel frame									
Casing	Galvanised steel									
Painting	Polyester - RAL 9002									
Insulation class	M1									

(1) All data are at Eurovent condition.

Cooling mode :

Water temperature = 12/7 °C

Condensing temperature = 45 °C

(2) At maximum compressor load.

HYDROLEAN	025	035	050	070	080	100	120	135	160
Evaporator/Condenser curve	A1	A2	B1	B2	B2	C1	C1	C2	C2

PLATE HEAT EXCHANGERS WITH PURE WATER

<i>Pressure Drop = a x (Flow Rate)^b</i>		
	a	b
A1	1,0120	1,7667
A2	0,6157	1,7983
B1	0,4345	1,8313
B2	0,3867	1,8448
C1	0,1230	1,8570
C2	0,0834	1,8751

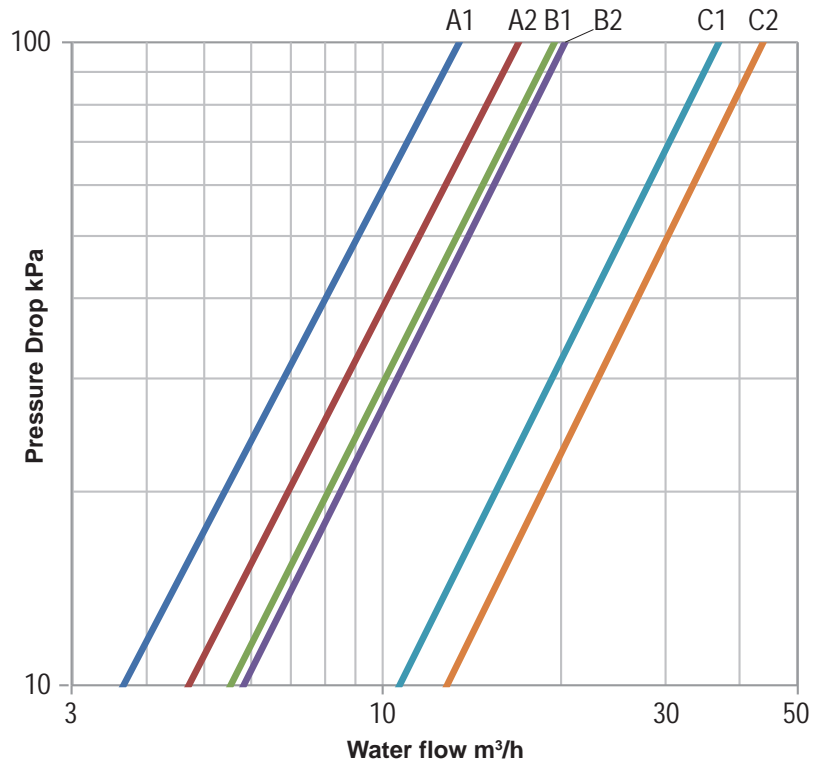
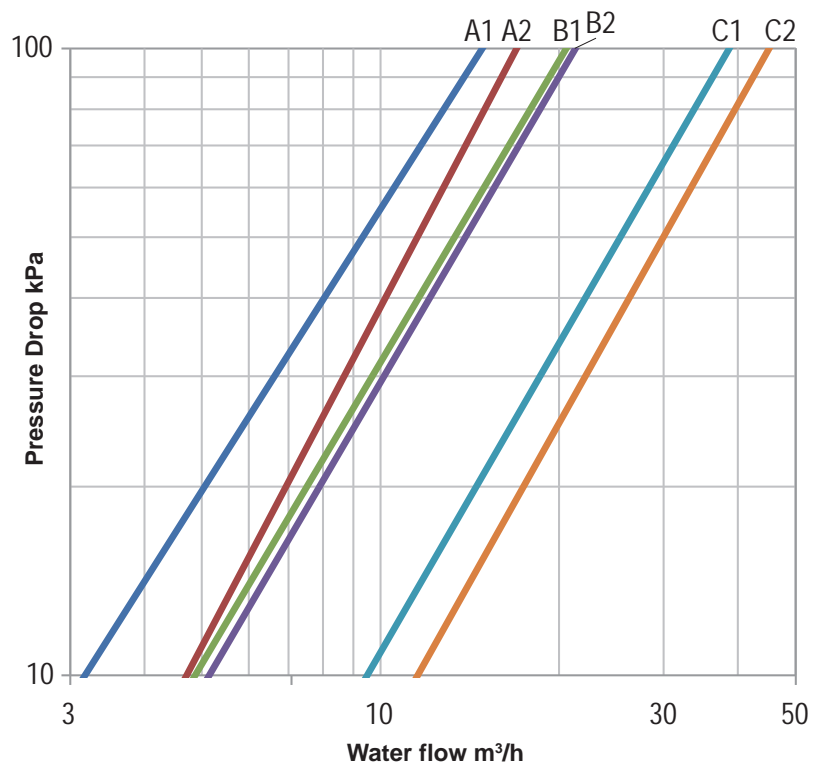

PLATE HEAT EXCHANGERS WITH WATER AND ETHYLENE GLYCOL 30%

<i>Pressure Drop = a x (Flow Rate)^b</i>		
	a	b
A1	1,7793	1,4938
A2	0,6157	1,7983
B1	0,7952	1,5990
B2	0,7044	1,6200
C1	0,2503	1,6386
C2	0,1608	1,6882



FILTERS

Pressure Drop = a x (Flow Rate)^b		
	a	b
W	2,5040	1,4570
X	0,8703	1,4907
Y	0,0051	2,6996
Z	0,0158	2,1394

Water filter diameter

W = 1" 1/2
 X = 2"
 Y = 2" 1/2
 Z = 3"

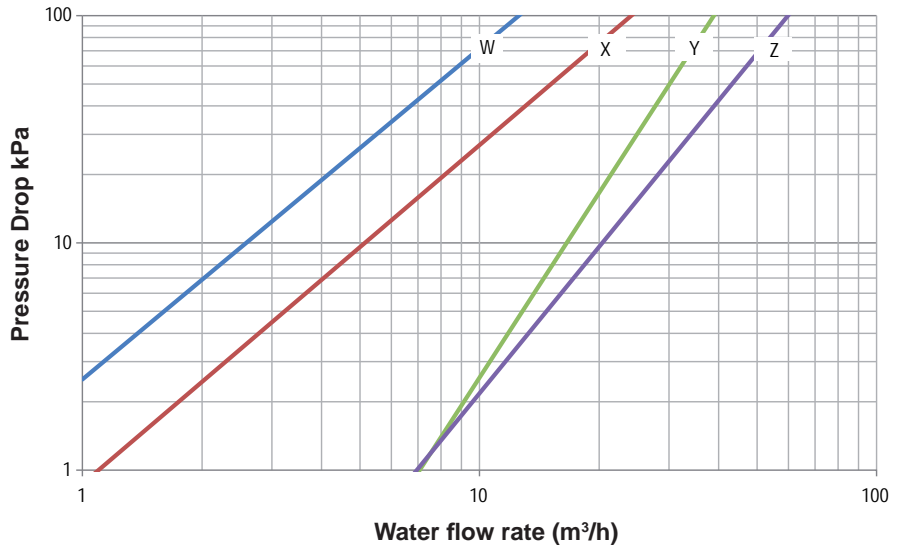

HYDROLEAN	025	035	050	070	080	100	120	135	160
Filter curve	W	X	X	Y	Y	Y	Y	Z	Z

"FULLY OPEN" PRESSOSTATIC CONTROL WATER VALVE

Pressure Drop = a x (Flow Rate)^b		
	a	b
WVFX25	5,8000	2,0000
WVS32	0,5095	2,1812
WVS40	0,2113	2,1423

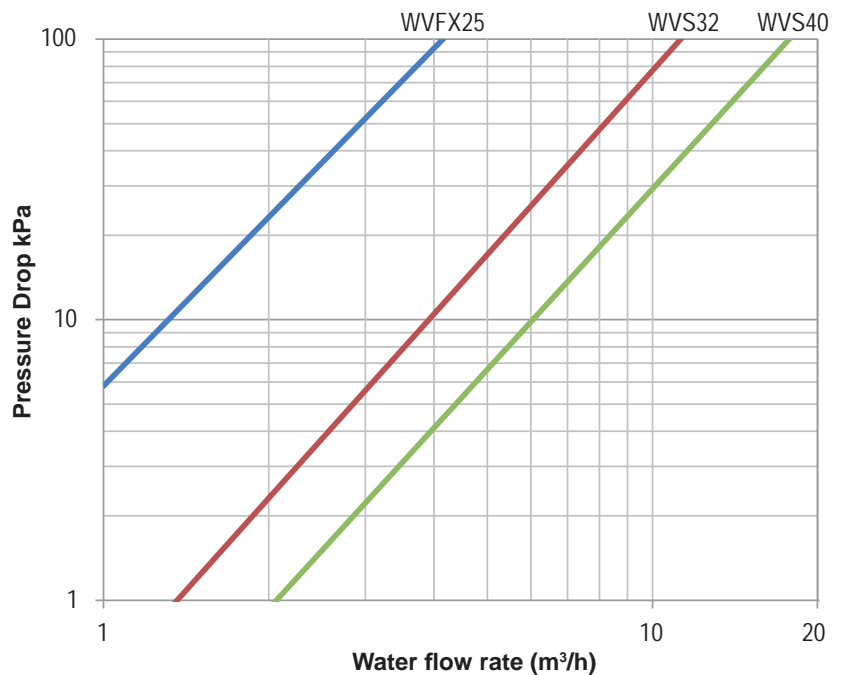

HYDROLEAN	025	035	050	070	080	100	120	135	160
Pressure regulated valve	WVFX25	WVFX25	WVS32	WVS32	WVS32	WVS32	WVS40	WVS40	WVS40

SEASONAL EFFICIENCY

ESEER (European Seasonal Energy Efficiency Ratio)- CALCULATIONS

SWC	ESEER	EER			
		Capacity load			
		100%	75%	50%	25%
025	4,78	4,36	4,73	4,95	4,63
035	4,59	4,25	4,58	4,75	4,36
050	5,40	4,25	4,93	5,69	5,71
070	5,13	3,90	4,67	5,47	5,36
080	4,80	3,86	4,43	5,06	5,00
100	5,68	4,25	5,29	5,87	6,11
120	5,55	4,04	5,00	5,86	5,97
135	5,33	4,16	4,96	5,53	5,64
160	5,25	3,97	4,72	5,71	5,37

SWH	ESEER	EER			
		Capacity load			
		100%	75%	50%	25%
025	4,57	4,16	4,51	4,73	4,41
035	4,48	4,14	4,47	4,64	4,26
050	5,48	4,14	4,92	5,81	5,86
070	4,72	3,72	4,41	5,00	4,80
080	4,62	3,66	4,30	4,86	4,78
100	5,26	4,20	4,91	5,65	5,22
120	5,33	3,93	4,75	5,54	5,96
135	5,14	4,08	4,90	5,44	5,07
160	5,12	3,93	4,70	5,42	5,37

Water cooled chillers		
Part load ratio	Condenser water inlet temperature	Part load rate
100%	30°C	3%
75%	26°C	33%
50%	22°C	41%
25%	18°C	23%

For evaporator side, the water is 12°C entry, 7°C leaving.
 For water cooled unit, consider 5° delta T on the condenser.
 Fouling factor = 0,000044 m²C/W".
 For water keep the flow defined at full load as constant at all capacity reduction.

CORRECTION TABLES

GLYCOL CORRECTION FACTOR

Minimum ambient temperature or water outlet temperature	Ethylene glycol	Pressure drop	Water flow	CAPACITIES	
				Cooling	Heating
From +5°C to 0°C	10%	1,05	1,02	0,99	0,994
From 0°C to -5°C	20%	1,10	1,05	0,98	0,993
From -5°C to -10°C	30%	1,15	1,08	0,97	0,99
From -10°C to -15°C	35%	1,18	1,10	0,96	0,987

Example : 10% glycol
 Minimum flow : 1,19 m³/h x 1,02
 Pressure drop x 1,07
 System capacity x 0,99

STANDARD UNITS

Spectrum per octave band (dBa)									Global sound power ⁽¹⁾ Lw dB(A)	Sound pressure 10 meters from the unit ⁽²⁾ Pw dB(A)	Sound pressure 10 meters from the unit ⁽³⁾ Pw dB(A)
SWC SWH SWR	63 Hz	125 Hz	250 Hz	500 Hz	1000 Hz	2000 Hz	4000 Hz	8000 Hz			
025	30,1	30,1	45,8	60,4	62,9	65,0	61,8	53,6	69,0	41,3	38,1
035	33,8	33,8	44,4	61,3	65,5	67,0	63,4	55,9	71,0	43,3	40,1
050	33,1	33,1	48,9	63,4	65,9	68,0	64,8	56,7	72,0	44,3	41,0
070	36,8	36,8	47,4	64,3	68,5	70,0	66,4	58,9	74,0	46,3	43,0
080	36,2	36,2	46,0	63,6	69,1	71,7	67,3	60,4	75,0	47,5	44,2
100	36,2	36,2	49,9	65,2	69,0	71,4	67,6	60,1	75,0	47,4	43,7
120	38,3	38,3	48,8	65,8	70,5	72,4	68,5	61,2	76,1	48,5	44,8
135	42,7	42,7	60,2	68,4	72,1	76,2	69,4	60,0	78,8	51,2	47,5
160	39,6	39,6	60,6	68,4	75,4	78,4	72,2	64,3	81,2	53,7	50,0

UNITS WITH ACOUSTIC JACKET ON COMPRESSOR(S) (OPTION)

Spectrum per octave band (dBa)									Global sound power ⁽¹⁾ Lw dB(A)	Sound pressure 10 meters from the unit ⁽²⁾ Pw dB(A)	Sound pressure 10 meters from the unit ⁽³⁾ Pw dB(A)
SWC SWH SWR	63 Hz	125 Hz	250 Hz	500 Hz	1000 Hz	2000 Hz	4000 Hz	8000 Hz			
025	40,8	40,8	50,9	57,2	52,6	52,4	50,5	43,9	60,6	31,2	28,0
035	42,3	42,3	48,2	57,2	54,5	54,3	52,6	46,1	61,5	32,6	29,4
050	43,8	43,8	53,9	60,2	55,6	55,4	53,5	46,9	63,6	34,2	30,9
070	45,3	45,3	51,2	60,2	57,5	57,3	55,6	49,2	64,5	35,6	32,3
080	45,9	45,9	51,3	59,4	58,0	59,0	56,5	50,6	64,9	36,4	33,1
100	46,4	46,4	54,9	61,7	58,3	58,7	56,5	50,3	65,9	36,8	33,1
120	47,2	47,2	53,0	61,7	59,5	59,7	57,7	51,5	66,4	37,7	34,0
135	46,6	46,6	62,9	65,3	62,4	65,5	59,0	49,8	70,7	41,6	37,9
160	46,4	46,4	63,4	65,5	66,1	67,9	62,0	53,3	72,5	44,1	40,4

(1) **SWC and SWH** : Global sound power data are valid for all evaporator temperature ranges and outlet condenser water temperatures equal or below 45°C

SWR : Global sound power data are valid for all evaporator temperature ranges and saturated condensing temperatures equal or below 55°C

(2) : Data are calculated by semi spheric method in free open field,

(3) : Data are calculated by enveloping surface method in free open field,

SWC / SWH

HYDROLEAN - SWC/SWH	025	035	050	070	080	100	120	135	160
Min. evaporator water outlet temperature	5 °C								
Min. evaporator water outlet temperature 30% glycol water	-10 °C								
Max. evaporator inlet water temperature	25 °C								
Max. evaporator outlet water temperature	20 °C								
Min. condenser inlet water temperature ⁽¹⁾	20 °C								
Min. condenser outlet water temperature	25 °C								
Max. condenser outlet water temperature	55 °C								

(1) Below this value, water pressostatic valve is mandatory (option).

**Operating diagram
SWC and SWH 025-035-070-080-100-120
Cooling and heating modes**

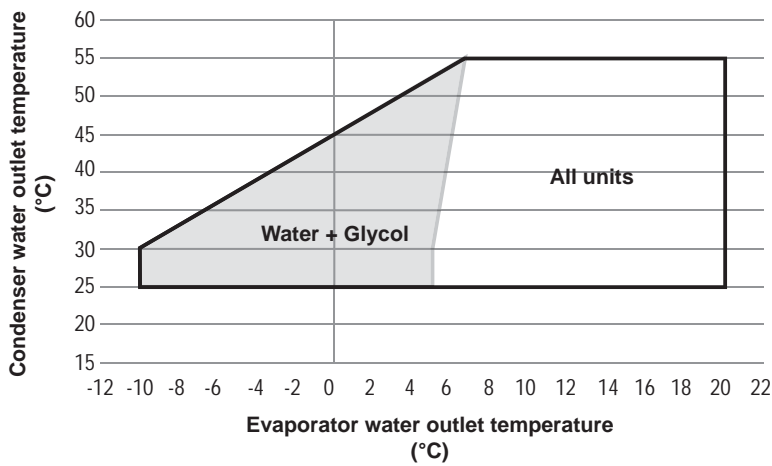

**Operating diagram
SWC and SWH 135-160
Cooling and heating modes**

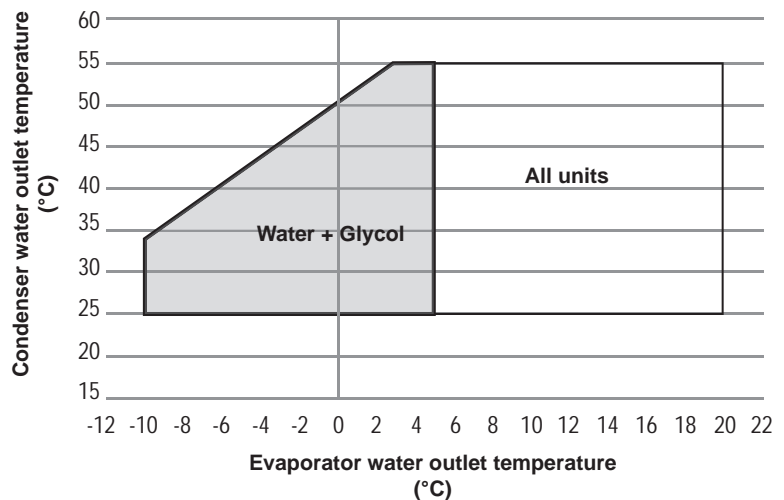

SWR

HYDROLEAN - SWR	025	035	050	070	080	100	120	135	160
Min. evaporator water outlet temperature	5 °C								
Min. evaporator water outlet temperature Eau glycolée 30%	-10 °C								
Max. evaporator inlet water temperature	25 °C								
Max. evaporator outlet water temperature	20 °C								
Min. condensing temperature	25 °C								
Max. condensing temperature	62 °C								

(1) Below this value, water pressostatic valve is mandatory (option).

Operating diagram
SWR 025-035-050-070-080-100-120
Cooling and heating modes

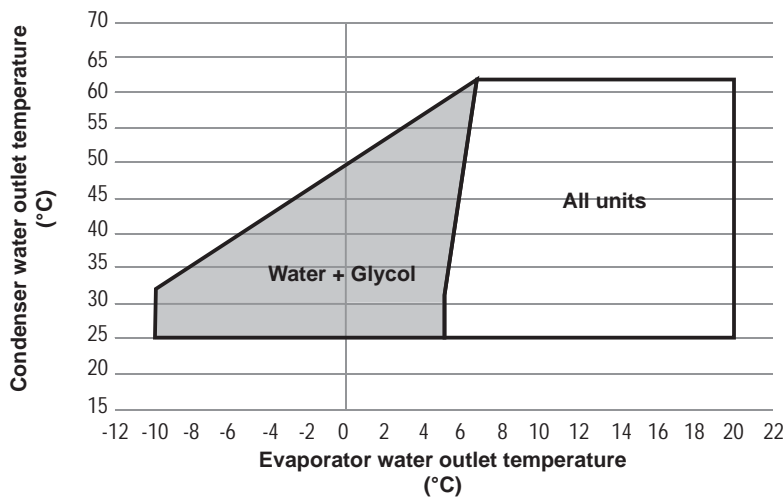

Operating diagram
SWR 135-160
Cooling and heating modes

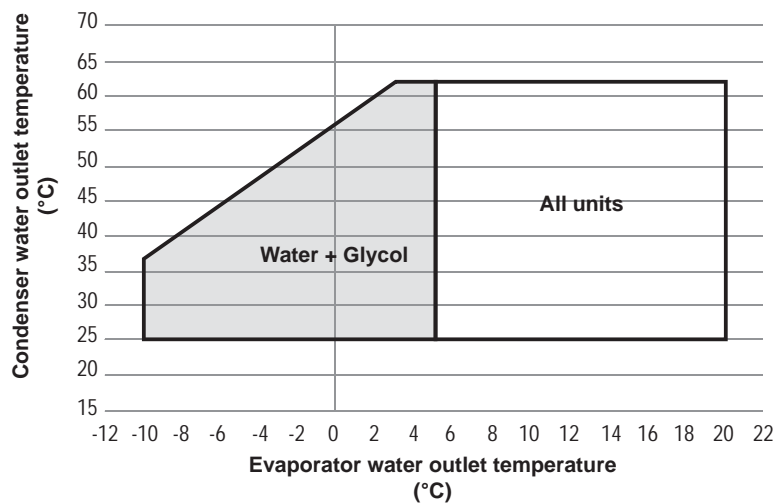

Evaporator outlet water temperature (°C)	SIZE	Condenser outlet water temperature (°C)											
		30°C				35°C				40°C			
		Pc	Pe	Wf	Dp	Pc	Pe	Wf	Dp	Pc	Pe	Wf	Dp
		kW	kW	m³/h	kPa	kW	kW	m³/h	kPa	kW	kW	m³/h	kPa
5°C	025	25,4	5,3	4,4	13,7	24,2	5,8	4,2	12,6	22,9	6,5	3,9	11,4
	035	37,4	8,1	6,4	17,5	35,7	8,8	6,1	16,1	33,8	9,7	5,8	14,6
	050	50,0	10,7	8,6	22,4	47,7	11,8	8,2	20,5	45,1	13,1	7,8	18,5
	070	70,9	16,6	12,2	39,0	68,0	18,3	11,7	36,1	64,6	20,1	11,1	32,9
	080	82,6	19,9	14,2	51,7	79,3	21,8	13,6	48,0	75,3	24,0	13,0	43,6
	100	94,4	20,2	16,2	21,8	89,9	22,3	15,5	19,9	85,0	24,6	14,6	17,9
	120	116,0	26,1	20,0	31,9	110,7	28,7	19,1	29,3	104,9	31,6	18,0	26,5
	135	131,0	28,6	22,5	28,7	124,8	31,3	21,5	26,2	117,8	34,5	20,3	23,5
	160	154,2	35,6	26,5	39,0	147,4	38,9	25,4	35,8	139,6	42,8	24,0	32,4
7°C	025	27,1	5,3	4,7	15,4	25,8	5,9	4,4	14,1	24,4	6,5	4,2	12,8
	035	39,8	8,2	6,9	19,6	38,0	8,9	6,5	18,0	36,0	9,8	6,2	16,3
	050	53,2	10,8	9,2	25,0	50,8	11,9	8,7	23,0	48,1	13,2	8,3	20,8
	070	74,9	16,9	12,9	43,2	71,9	18,5	12,4	40,1	68,4	20,4	11,8	36,5
	080	87,0	20,3	15,0	56,9	83,6	22,2	14,4	52,9	79,7	24,3	13,7	48,5
	100	100,5	20,5	17,3	24,4	95,7	22,5	16,5	22,3	90,5	24,8	15,6	20,1
	120	123,0	26,5	21,2	35,6	117,5	29,1	20,2	32,7	111,3	32,0	19,2	29,6
	135	139,4	29,1	24,0	32,3	132,7	31,7	22,8	29,4	125,5	34,9	21,6	26,5
	160	163,6	36,2	28,2	43,6	156,4	39,5	26,9	40,0	148,3	43,3	25,5	36,2
9°C	025	28,8	5,4	5,0	17,1	27,4	5,9	4,7	15,7	26,0	6,6	4,5	14,3
	035	42,3	8,3	7,3	21,9	40,4	9,0	6,9	20,1	38,2	9,9	6,6	18,2
	050	56,4	10,9	9,7	27,9	53,9	12,0	9,3	25,7	51,1	13,3	8,8	23,3
	070	79,1	17,2	13,6	47,8	76,0	18,8	13,1	44,3	72,3	20,6	12,4	40,5
	080	91,3	20,6	15,7	62,3	88,0	22,5	15,1	58,2	84,1	24,7	14,5	53,5
	100	106,7	20,7	18,4	27,4	101,7	22,7	17,5	25,0	96,3	25,1	16,6	22,6
	120	130,3	27,0	22,4	39,6	124,5	29,5	21,4	36,4	118,1	32,4	20,3	33,0
	135	148,0	29,5	25,5	36,1	141,0	32,2	24,3	33,0	133,4	35,3	23,0	29,7
	160	173,3	36,8	29,8	48,5	165,7	40,1	28,5	44,6	157,3	43,8	27,1	40,5

Pc : Net cooling capacity in kW	Pe(c) : Effective absorbed power in cooling mode	Wf : Water flow in m³ per Hour	Dp : Water pressure drop in KPa
5 °C Δ Water inlet / outlet Temperature		Fouling factor : 0,000044 m² °C / W	

SWC

Cooling only

Evaporator outlet water temperature (°C)	SIZE	Condenser outlet water temperature (°C)											
		45°C				50°C				55°C			
		Pc	Pe	Wf	Dp	Pc	Pe	Wf	Dp	Pc	Pe	Wf	Dp
		kW	kW	m ³ /h	kPa	kW	kW	m ³ /h	kPa	kW	kW	m ³ /h	kPa
5°C	025	21,4	7,3	3,7	10,2	19,9	8,1	3,4	8,9	18,2	9,1	3,1	7,6
	035	31,7	10,8	5,4	13,0	29,3	11,9	5,0	11,3	26,8	13,2	4,6	9,6
	050	42,3	14,7	7,3	16,5	39,3	16,4	6,8	14,4	36,0	18,3	6,2	12,2
	070	60,7	22,2	10,4	29,3	56,4	24,6	9,7	25,6	51,6	27,2	8,9	21,7
	080	70,8	26,3	12,2	38,9	65,6	28,9	11,3	33,9	59,9	31,7	10,3	28,6
	100	79,6	27,4	13,7	15,9	73,8	30,4	12,7	13,8	67,6	33,8	11,6	11,7
	120	98,3	34,9	16,9	23,5	91,1	38,5	15,7	20,4	83,3	42,5	14,3	17,3
	135	110,3	38,2	19,0	20,8	102,2	42,4	17,6	18,0	93,5	47,0	16,1	15,2
	160	131,1	47,1	22,6	28,7	121,7	52,0	20,9	25,0	111,5	57,3	19,2	21,2
7°C	025	22,9	7,3	3,9	11,4	21,3	8,1	3,7	10,0	19,6	9,1	3,4	8,6
	035	33,7	10,9	5,8	14,5	31,3	12,0	5,4	12,7	28,6	13,3	4,9	10,8
	050	45,2	14,7	7,8	18,6	42,0	16,5	7,2	16,2	38,6	18,4	6,6	13,9
	070	64,4	22,5	11,1	32,7	59,9	24,8	10,3	28,6	55,0	27,4	9,5	24,4
	080	75,2	26,7	12,9	43,5	70,1	29,3	12,1	38,2	64,4	32,1	11,1	32,7
	100	84,9	27,5	14,6	17,9	78,8	30,6	13,6	15,6	72,4	33,9	12,4	13,3
	120	104,5	35,2	18,0	26,3	97,1	38,9	16,7	22,9	88,9	42,9	15,3	19,5
	135	117,6	38,6	20,2	23,5	109,2	42,7	18,8	20,4	100,1	47,3	17,2	17,3
	160	139,4	47,6	24,0	32,3	129,7	52,4	22,3	28,2	119,1	57,7	20,5	24,0
9°C	025	24,4	7,3	4,2	12,8	22,7	8,2	3,9	11,3	20,9	9,1	3,6	9,7
	035	35,9	11,0	6,2	16,2	33,3	12,1	5,7	14,2	30,5	13,4	5,3	12,2
	050	48,1	14,8	8,3	20,8	44,8	16,5	7,7	18,3	41,3	18,4	7,1	15,8
	070	68,2	22,7	11,7	36,3	63,6	25,1	10,9	32,0	58,5	27,6	10,1	27,4
	080	79,7	27,0	13,7	48,4	74,6	29,6	12,8	42,8	68,9	32,5	11,8	37,0
	100	90,4	27,7	15,6	20,1	84,1	30,7	14,5	17,6	77,4	34,1	13,3	15,0
	120	111,0	35,6	19,1	29,4	103,2	39,2	17,8	25,7	94,8	43,2	16,3	22,0
	135	125,2	38,9	21,5	26,4	116,4	43,1	20,0	23,0	107,0	47,6	18,4	19,6
	160	148,1	48,1	25,5	36,1	138,0	52,9	23,7	31,7	127,1	58,2	21,9	27,1

Pc :	Net cooling capacity in kW	Pe(c) :	Effective absorbed power in cooling mode	Wf :	Water flow in m ³ per Hour	Dp :	Water pressure drop in KPa
5 °C Δ Water inlet / outlet Temperature				Fouling factor : 0,000044 m ² °C / W			

SWH

Cooling mode

Evaporator outlet water temperature (°C)	SIZE	Condenser outlet water temperature (°C)											
		30°C				35°C				40°C			
		Pc	Pe	Wf	Dp	Pc	Pe	Wf	Dp	Pc	Pe	Wf	Dp
		kW	kW	m ³ /h	kPa	kW	kW	m ³ /h	kPa	kW	kW	m ³ /h	kPa
5°C	025	25,2	5,4	4,3	13,5	24,0	6,0	4,1	12,4	22,6	6,6	3,9	11,2
	035	37,1	8,2	6,4	17,3	35,4	9,0	6,1	15,8	33,4	9,9	5,7	14,3
	050	49,6	10,9	8,5	22,1	47,3	12,0	8,1	20,2	44,7	13,4	7,7	18,2
	070	70,5	16,8	12,1	38,6	67,6	18,5	11,6	35,7	64,2	20,4	11,0	32,5
	080	80,3	19,1	13,8	49,1	76,9	20,8	13,2	45,4	73,0	22,8	12,6	41,2
	100	93,8	20,5	16,1	21,5	89,1	22,6	15,3	19,5	83,9	25,1	14,4	17,5
	120	114,9	26,6	19,8	31,4	109,6	29,2	18,9	28,7	103,6	32,2	17,8	25,9
	135	130,2	28,9	22,4	28,4	123,9	31,7	21,3	25,9	116,9	35,0	20,1	23,2
	160	153,6	35,9	26,4	38,7	146,6	39,3	25,2	35,5	138,8	43,2	23,9	32,0
7°C	025	26,8	5,4	4,6	15,1	25,5	6,0	4,4	13,8	24,1	6,7	4,2	12,5
	035	39,5	8,3	6,8	19,3	37,6	9,1	6,5	17,7	35,6	10,0	6,1	16,0
	050	52,8	11,0	9,1	24,7	50,3	12,1	8,7	22,6	47,6	13,5	8,2	20,4
	070	74,6	17,1	12,8	42,9	71,6	18,7	12,3	39,7	68,0	20,6	11,7	36,1
	080	85,4	19,3	14,7	55,0	81,8	21,0	14,1	50,8	77,7	22,9	13,4	46,2
	100	100,0	20,6	17,2	24,2	95,0	22,8	16,3	22,0	89,6	25,2	15,4	19,8
	120	122,1	27,0	21,0	35,1	116,5	29,5	20,0	32,2	110,2	32,5	19,0	29,0
	135	138,6	29,4	23,8	31,9	131,9	32,1	22,7	29,1	124,6	35,3	21,4	26,1
	160	163,1	36,4	28,1	43,3	155,8	39,7	26,8	39,7	147,6	43,6	25,4	35,9
9°C	025	28,5	5,5	4,9	16,8	27,2	6,1	4,7	15,4	25,7	6,7	4,4	14,0
	035	42,0	8,4	7,2	21,5	40,0	9,2	6,9	19,8	37,8	10,1	6,5	17,9
	050	56,0	11,1	9,6	27,6	53,5	12,2	9,2	25,3	50,6	13,6	8,7	22,9
	070	78,8	17,3	13,6	47,5	75,7	18,9	13,0	44,0	72,0	20,8	12,4	40,1
	080	90,7	19,6	15,6	61,5	86,9	21,2	15,0	56,8	82,6	23,1	14,2	51,7
	100	106,3	20,8	18,3	27,1	101,1	23,0	17,4	24,7	95,5	25,4	16,4	22,3
	120	129,4	27,3	22,3	39,1	123,6	29,9	21,3	35,9	117,1	32,8	20,1	32,5
	135	147,3	29,8	25,3	35,8	140,3	32,5	24,1	32,6	132,6	35,7	22,8	29,4
	160	172,9	37,0	29,7	48,3	165,2	40,3	28,4	44,4	156,7	44,1	27,0	40,2

Pc :	Net cooling capacity in kW	Pe(c) :	Effective absorbed power in cooling mode	Wf :	Water flow in m ³ per Hour	Dp :	Water pressure drop in KPa
5 °C Δ Water inlet / outlet Temperature				Fouling factor : 0,000044 m ² °C / W			

SWH

Cooling mode

Evaporator outlet water temperature (°C)	SIZE	Condenser outlet water temperature (°C)											
		45°C				50°C				55°C			
		Pc	Pe	Wf	Dp	Pc	Pe	Wf	Dp	Pc	Pe	Wf	Dp
		kW	kW	m ³ /h	kPa	kW	kW	m ³ /h	kPa	kW	kW	m ³ /h	kPa
5°C	025	21,1	7,4	3,6	9,9	19,6	8,3	3,4	8,6	17,8	9,3	3,1	7,3
	035	31,2	11,0	5,4	12,7	28,9	12,2	5,0	11,0	26,3	13,5	4,5	9,3
	050	41,8	15,0	7,2	16,1	38,7	16,7	6,7	14,0	35,3	18,7	6,1	11,8
	070	60,2	22,5	10,4	28,9	55,8	24,9	9,6	25,1	50,9	27,5	8,8	21,2
	080	68,5	25,1	11,8	36,6	63,5	27,8	10,9	31,8	57,8	30,9	9,9	26,8
	100	78,3	27,9	13,5	15,4	72,3	31,0	12,4	13,3	65,8	34,4	11,3	11,1
	120	97,0	35,5	16,7	22,9	89,7	39,3	15,4	19,8	81,7	43,4	14,1	16,7
	135	109,3	38,7	18,8	20,4	101,0	42,9	17,4	17,6	92,2	47,7	15,9	14,9
	160	130,2	47,6	22,4	28,4	120,6	52,5	20,8	24,6	110,3	57,9	19,0	20,8
7°C	025	22,6	7,4	3,9	11,1	20,9	8,3	3,6	9,7	19,2	9,3	3,3	8,3
	035	33,3	11,1	5,7	14,2	30,8	12,3	5,3	12,3	28,1	13,6	4,8	10,5
	050	44,6	15,0	7,7	18,2	41,4	16,8	7,1	15,8	38,0	18,7	6,5	13,5
	070	64,0	22,7	11,0	32,3	59,4	25,1	10,2	28,2	54,4	27,7	9,4	23,9
	080	73,0	25,3	12,6	41,2	67,7	27,9	11,6	35,9	61,9	30,9	10,6	30,4
	100	83,8	28,0	14,4	17,5	77,6	31,0	13,3	15,1	70,9	34,4	12,2	12,8
	120	103,3	35,8	17,8	25,7	95,7	39,5	16,5	22,3	87,5	43,6	15,0	18,9
	135	116,6	39,0	20,1	23,1	108,0	43,2	18,6	20,0	98,8	47,9	17,0	16,9
	160	138,6	48,0	23,8	31,9	128,7	52,9	22,1	27,8	118,0	58,3	20,3	23,6
9°C	025	24,1	7,5	4,1	12,5	22,4	8,4	3,9	11,0	20,6	9,3	3,5	9,4
	035	35,4	11,2	6,1	15,9	32,8	12,3	5,6	13,8	30,0	13,7	5,2	11,8
	050	47,6	15,1	8,2	20,4	44,3	16,8	7,6	17,9	40,7	18,8	7,0	15,3
	070	67,8	22,9	11,7	35,9	63,1	25,3	10,9	31,5	58,0	27,9	10,0	26,9
	080	77,7	25,4	13,4	46,2	72,2	28,1	12,4	40,3	66,1	31,1	11,4	34,3
	100	89,5	28,1	15,4	19,7	83,1	31,2	14,3	17,2	76,2	34,5	13,1	14,6
	120	109,9	36,1	18,9	28,9	102,0	39,8	17,6	25,2	93,5	43,8	16,1	21,4
	135	124,3	39,4	21,4	26,0	115,3	43,6	19,8	22,6	105,8	48,2	18,2	19,2
	160	147,4	48,4	25,4	35,8	137,2	53,3	23,6	31,3	126,1	58,6	21,7	26,7

Pc :	Net cooling capacity in kW	Pe(c) :	Effective absorbed power in cooling mode	Wf :	Water flow in m ³ per Hour	Dp :	Water pressure drop in KPa
5 °C Δ Water inlet / outlet Temperature				Fouling factor : 0,000044 m ² °C / W			

SWH

Heating mode

Evaporator outlet water temperature (°C)	SIZE	Condenser outlet water temperature (°C)											
		30°C				35°C				40°C			
		Pc	Pe	Wf	Dp	Pc	Pe	Wf	Dp	Pc	Pe	Wf	Dp
		kW	kW	m ³ /h	kPa	kW	kW	m ³ /h	kPa	kW	kW	m ³ /h	kPa
5°C	025	29,1	5,4	5,0	17,4	28,4	6,0	4,9	16,7	27,8	6,6	4,8	16,1
	035	43,0	8,2	7,4	22,5	42,1	9,0	7,3	21,7	41,2	9,9	7,1	20,8
	050	57,5	10,9	9,9	28,9	56,3	12,0	9,7	27,8	55,1	13,4	9,5	26,7
	070	83,0	16,8	14,3	52,2	81,7	18,5	14,1	50,7	80,3	20,4	13,8	49,1
	080	94,4	19,1	16,2	66,2	92,8	20,8	16,0	64,1	91,0	22,8	15,7	61,8
	100	108,6	20,5	18,7	28,2	106,1	22,6	18,3	27,1	103,6	25,1	17,8	25,9
	120	134,5	26,6	23,1	42,0	131,9	29,2	22,7	40,5	129,0	32,2	22,2	38,9
	135	151,2	28,9	26,0	37,6	147,8	31,7	25,4	36,0	144,3	35,0	24,8	34,4
	160	180,0	35,9	31,0	52,1	176,6	39,3	30,4	50,3	172,9	43,2	29,7	48,3
7°C	025	30,7	5,4	5,3	19,1	30,0	6,0	5,2	18,4	29,3	6,7	5,0	17,6
	035	45,4	8,3	7,8	24,8	44,4	9,1	7,6	23,8	43,3	10,0	7,5	22,8
	050	60,6	11,0	10,4	31,8	59,3	12,1	10,2	30,6	58,0	13,5	10,0	29,4
	070	87,1	17,1	15,0	57,0	85,7	18,7	14,8	55,4	84,2	20,6	14,5	53,5
	080	99,5	19,3	17,1	72,9	97,7	21,0	16,8	70,5	95,6	22,9	16,4	67,7
	100	114,6	20,6	19,7	31,2	111,9	22,8	19,3	29,9	109,1	25,2	18,8	28,5
	120	141,6	27,0	24,4	46,2	138,7	29,5	23,9	44,5	135,6	32,5	23,3	42,6
	135	159,6	29,4	27,5	41,6	155,8	32,1	26,8	39,7	151,9	35,3	26,1	37,9
	160	189,5	36,4	32,6	57,4	185,7	39,7	32,0	55,3	181,6	43,6	31,3	53,0
9°C	025	32,3	5,5	5,6	21,0	31,6	6,1	5,4	20,1	30,8	6,7	5,3	19,3
	035	47,9	8,4	8,2	27,3	46,7	9,2	8,0	26,1	45,5	10,1	7,8	25,0
	050	63,8	11,1	11,0	34,9	62,4	12,2	10,7	33,6	61,0	13,6	10,5	32,2
	070	91,3	17,3	15,7	62,3	89,9	18,9	15,5	60,4	88,1	20,8	15,2	58,3
	080	104,8	19,6	18,0	80,2	102,7	21,2	17,7	77,3	100,4	23,1	17,3	74,2
	100	120,8	20,8	20,8	34,4	117,9	23,0	20,3	32,9	114,9	25,4	19,8	31,4
	120	148,9	27,3	25,6	50,8	145,8	29,9	25,1	48,8	142,4	32,8	24,5	46,7
	135	168,2	29,8	28,9	45,9	164,1	32,5	28,2	43,8	159,9	35,7	27,5	41,7
	160	199,4	37,0	34,3	63,1	195,2	40,3	33,6	60,7	190,8	44,1	32,8	58,1

Pc :	Net cooling capacity in kW	Pe(c) :	Effective absorbed power in cooling mode	Wf :	Water flow in m ³ per Hour	Dp :	Water pressure drop in KPa
5 °C Δ Water inlet / outlet Temperature				Fouling factor : 0,000044 m ² °C / W			

SWH

Heating mode

Evaporator outlet water temperature (°C)	SIZE	Condenser outlet water temperature (°C)											
		45°C				50°C				55°C			
		Pc	Pe	Wf	Dp	Pc	Pe	Wf	Dp	Pc	Pe	Wf	Dp
		kW	kW	m ³ /h	kPa	kW	kW	m ³ /h	kPa	kW	kW	m ³ /h	kPa
5°C	025	27,1	7,4	4,7	15,4	26,5	8,3	4,6	14,7	25,8	9,3	4,4	14,1
	035	40,1	11,0	6,9	19,9	39,0	12,2	6,7	18,9	37,8	13,5	6,5	17,8
	050	53,9	15,0	9,3	25,7	52,7	16,7	9,1	24,6	51,4	18,7	8,8	23,5
	070	78,6	22,5	13,5	47,2	76,7	24,9	13,2	45,1	74,5	27,5	12,8	42,8
	080	88,9	25,1	15,3	59,3	86,7	27,8	14,9	56,6	84,2	30,9	14,5	53,7
	100	100,9	27,9	17,4	24,6	98,1	31,0	16,9	23,4	95,2	34,4	16,4	22,1
	120	125,9	35,5	21,7	37,2	122,5	39,3	21,1	35,3	118,8	43,4	20,4	33,4
	135	140,6	38,7	24,2	32,8	136,8	42,9	23,5	31,1	132,8	47,7	22,9	29,5
	160	168,8	47,6	29,0	46,2	164,5	52,5	28,3	44,0	159,8	57,9	27,5	41,7
7°C	025	28,5	7,4	4,9	16,8	27,8	8,3	4,8	16,1	27,1	9,3	4,7	15,3
	035	42,1	11,1	7,3	21,7	40,9	12,3	7,0	20,6	39,6	13,6	6,8	19,4
	050	56,7	15,0	9,7	28,1	55,3	16,8	9,5	26,9	53,9	18,7	9,3	25,6
	070	82,3	22,7	14,2	51,4	80,3	25,1	13,8	49,1	78,0	27,7	13,4	46,5
	080	93,3	25,3	16,1	64,8	90,9	27,9	15,6	61,7	88,2	30,9	15,2	58,4
	100	106,2	28,0	18,3	27,1	103,2	31,0	17,8	25,7	100,1	34,4	17,2	24,3
	120	132,2	35,8	22,7	40,7	128,5	39,5	22,1	38,6	124,5	43,6	21,4	36,4
	135	147,9	39,0	25,4	36,0	143,7	43,2	24,7	34,2	139,4	47,9	24,0	32,3
	160	177,2	48,0	30,5	50,6	172,5	52,9	29,7	48,1	167,5	58,3	28,8	45,5
9°C	025	30,0	7,5	5,2	18,4	29,2	8,4	5,0	17,5	28,4	9,3	4,9	16,7
	035	44,3	11,2	7,6	23,7	42,9	12,3	7,4	22,4	41,5	13,7	7,1	21,1
	050	59,5	15,1	10,2	30,8	58,0	16,8	10,0	29,4	56,5	18,8	9,7	28,0
	070	86,2	22,9	14,8	56,0	84,0	25,3	14,5	53,4	81,6	27,9	14,0	50,6
	080	97,9	25,4	16,8	70,8	95,2	28,1	16,4	67,3	92,3	31,1	15,9	63,5
	100	111,7	28,1	19,2	29,8	108,5	31,2	18,7	28,2	105,1	34,5	18,1	26,6
	120	138,7	36,1	23,9	44,5	134,7	39,8	23,2	42,1	130,4	43,8	22,4	39,7
	135	155,5	39,4	26,7	39,6	151,0	43,6	26,0	37,5	146,3	48,2	25,2	35,3
	160	186,0	48,4	32,0	55,4	180,9	53,3	31,1	52,6	175,5	58,6	30,2	49,7

Pc :	Net cooling capacity in kW	Pe(c) :	Effective absorbed power in cooling mode	Wf :	Water flow in m ³ per Hour	Dp :	Water pressure drop in KPa
5 °C Δ Water inlet / outlet Temperature				Fouling factor : 0,000044 m ² °C / W			

Unit with remote condenser

Evaporator outlet water temperature (°C)	SIZE	Condenser outlet water temperature (°C)											
		30°C				35°C				40°C			
		Pc	Pe	Wf	Dp	Pc	Pe	Wf	Dp	Pc	Pe	Wf	Dp
		kW	kW	m ³ /h	kPa	kW	kW	m ³ /h	kPa	kW	kW	m ³ /h	kPa
5°C	025	25,1	5,5	4,3	13,4	23,8	6,1	4,1	12,2	22,4	6,8	3,9	11,0
	035	37,0	8,3	6,4	17,1	35,2	9,1	6,1	15,7	33,2	10,1	5,7	14,1
	050	49,4	11,0	8,5	21,9	47,0	12,2	8,1	20,0	44,3	13,6	7,6	17,9
	070	70,7	16,9	12,2	38,8	67,7	18,5	11,6	35,9	64,2	20,4	11,1	32,5
	080	82,7	20,3	14,2	51,8	79,4	22,3	13,7	48,1	75,4	24,5	13,0	43,7
	100	93,5	20,7	16,1	21,4	88,9	22,8	15,3	19,5	83,7	25,3	14,4	17,4
	120	115,5	26,6	19,9	31,7	110,2	29,1	19,0	29,0	104,2	32,1	17,9	26,2
	135	130,0	29,6	22,4	28,3	123,5	32,4	21,3	25,7	116,4	35,7	20,0	23,0
	160	154,1	36,1	26,5	38,9	147,0	39,5	25,3	35,7	139,1	43,5	23,9	32,1
7°C	025	26,7	5,5	4,6	15,0	25,4	6,1	4,4	13,7	23,9	6,8	4,1	12,3
	035	39,4	8,4	6,8	19,2	37,5	9,2	6,4	17,6	35,3	10,1	6,1	15,8
	050	52,6	11,1	9,1	24,6	50,1	12,3	8,6	22,5	47,3	13,7	8,1	20,2
	070	74,9	17,0	12,9	43,1	71,8	18,6	12,4	39,9	68,2	20,5	11,7	36,3
	080	87,2	20,5	15,0	57,2	84,0	22,5	14,5	53,4	80,1	24,7	13,8	48,9
	100	99,7	20,8	17,2	24,1	94,8	22,9	16,3	21,9	89,4	25,4	15,4	19,7
	120	122,9	26,8	21,1	35,5	117,3	29,3	20,2	32,6	110,9	32,3	19,1	29,4
	135	138,6	29,8	23,8	31,9	131,8	32,6	22,7	29,0	124,2	35,9	21,4	26,0
	160	163,9	36,4	28,2	43,7	156,5	39,8	26,9	40,1	148,2	43,7	25,5	36,2
9°C	025	28,4	5,5	4,9	16,7	27,0	6,1	4,7	15,3	25,5	6,8	4,4	13,8
	035	41,9	8,4	7,2	21,5	39,9	9,2	6,9	19,6	37,6	10,2	6,5	17,7
	050	55,9	11,2	9,6	27,5	53,3	12,3	9,2	25,1	50,4	13,7	8,7	22,7
	070	79,2	17,1	13,6	47,9	76,0	18,8	13,1	44,4	72,3	20,7	12,4	40,4
	080	91,8	20,6	15,8	62,9	88,7	22,6	15,3	59,0	84,8	24,9	14,6	54,3
	100	106,2	21,0	18,3	27,1	101,0	23,0	17,4	24,7	95,3	25,5	16,4	22,2
	120	130,5	27,0	22,5	39,7	124,6	29,6	21,4	36,5	118,0	32,5	20,3	32,9
	135	147,5	30,1	25,4	35,9	140,3	32,8	24,1	32,7	132,4	36,1	22,8	29,3
	160	174,1	36,7	29,9	48,9	166,3	40,0	28,6	44,9	157,7	43,9	27,1	40,6

Pc :	Net cooling capacity in kW	Pe(c) :	Effective absorbed power in cooling mode	Wf :	Water flow in m ³ per Hour	Dp :	Water pressure drop in KPa
5 °C Δ Water inlet / outlet Temperature				Fouling factor : 0,000044 m ² °C / W			

SWR
Unit with remote condenser

Evaporator outlet water temperature (°C)	SIZE	Condenser outlet water temperature (°C)											
		45°C				50°C				55°C			
		Pc	Pe	Wf	Dp	Pc	Pe	Wf	Dp	Pc	Pe	Wf	Dp
		kW	kW	m³/h	kPa	kW	kW	m³/h	kPa	kW	kW	m³/h	kPa
5°C	025	20,9	7,6	3,6	9,7	19,3	8,5	3,3	8,4	17,5	9,5	3,0	7,1
	035	30,9	11,2	5,3	12,4	28,5	12,4	4,9	10,7	25,8	13,8	4,4	9,0
	050	41,4	15,3	7,1	15,8	38,2	17,1	6,6	13,7	34,8	19,1	6,0	11,5
	070	60,2	22,6	10,4	28,9	55,7	25,1	9,6	25,0	50,6	27,9	8,7	21,0
	080	70,7	27,0	12,2	38,8	65,3	29,7	11,2	33,5	59,2	32,7	10,2	28,0
	100	78,2	28,1	13,4	15,3	72,1	31,3	12,4	13,2	65,6	34,9	11,3	11,1
	120	97,4	35,5	16,8	23,1	89,9	39,4	15,5	19,9	81,6	43,7	14,0	16,6
	135	108,6	39,6	18,7	20,2	100,1	43,9	17,2	17,3	91,0	48,9	15,7	14,5
	160	130,3	48,0	22,4	28,4	120,6	53,1	20,7	24,6	109,9	58,8	18,9	20,7
7°C	025	22,4	7,6	3,8	10,9	20,7	8,5	3,6	9,5	18,9	9,5	3,2	8,1
	035	33,0	11,2	5,7	14,0	30,4	12,5	5,2	12,1	27,7	13,8	4,8	10,2
	050	44,3	15,3	7,6	17,9	41,0	17,1	7,1	15,6	37,5	19,1	6,4	13,2
	070	64,1	22,7	11,0	32,4	59,4	25,2	10,2	28,2	54,2	27,9	9,3	23,8
	080	75,4	27,2	13,0	43,8	70,1	29,9	12,1	38,2	64,1	32,9	11,0	32,4
	100	83,6	28,2	14,4	17,4	77,2	31,4	13,3	15,0	70,5	35,0	12,1	12,7
	120	103,8	35,7	17,9	26,0	96,0	39,6	16,5	22,5	87,5	43,9	15,0	18,9
	135	116,1	39,7	20,0	22,9	107,2	44,1	18,5	19,7	97,7	49,0	16,8	16,6
	160	139,0	48,2	23,9	32,1	128,9	53,2	22,2	27,9	117,9	58,9	20,3	23,6
9°C	025	23,9	7,6	4,1	12,3	22,1	8,5	3,8	10,7	20,3	9,5	3,5	9,2
	035	35,2	11,3	6,0	15,7	32,5	12,5	5,6	13,6	29,6	13,9	5,1	11,5
	050	47,3	15,3	8,1	20,2	43,9	17,1	7,5	17,6	40,2	19,1	6,9	15,0
	070	68,0	22,8	11,7	36,2	63,3	25,3	10,9	31,6	58,0	28,0	10,0	26,9
	080	80,2	27,4	13,8	49,0	74,9	30,1	12,9	43,2	68,9	33,1	11,9	37,0
	100	89,2	28,3	15,3	19,6	82,6	31,5	14,2	17,0	75,6	35,0	13,0	14,4
	120	110,6	35,9	19,0	29,2	102,5	39,7	17,6	25,4	93,6	44,0	16,1	21,4
	135	123,9	39,9	21,3	25,9	114,7	44,2	19,7	22,4	104,8	49,1	18,0	18,9
	160	148,1	48,4	25,5	36,1	137,6	53,4	23,7	31,5	126,3	59,0	21,7	26,8

Pc :	Net cooling capacity in kW	Pe(c) :	Effective absorbed power in cooling mode	Wf :	Water flow in m³ per Hour	Dp :	Water pressure drop in KPa
5 °C Δ Water inlet / outlet Temperature				Fouling factor : 0,000044 m² °C / W			

HYDROLEAN	SWC	025	035	050	070	080	100	120	135	160	
Units											
Minimum and maximum voltage ⁽¹⁾		380-420V 50Hz									
Options											
First external fan ⁽²⁾	kW	2,00									
Protection range provided	A	2,5 > 4A									
Second external fan ⁽²⁾	kW	2,00									
Protection range provided	A	2,5 > 4A									
Third external fan ⁽²⁾	kW	-	2,00								
Protection range provided	A	-	2,5 > 4A								
Fourth external fan ⁽²⁾	kW	-					2,00				
Protection range provided	A	-					2,5 > 4A				
One external pump for evaporator ⁽²⁾	kW	1,0	1,7				2,6	4,2			
Protection range provided	A	1,6 > 2,5 A	2,5 > 4 A				4 > 6,3 A	6,0 > 10 A			
One external pump for condenser ⁽²⁾	kW	1,0	1,7				2,6	4,2			
Protection range provided	A	1,6 > 2,5 A	2,5 > 4 A				4 > 6,3A	6,0 > 10 A			

(1) Minimum and Maximum Voltage are given for the unit only and can not apply to external components such as Pumps or Fans.

(2) Max kW with 400V and CosPhi = 0,72

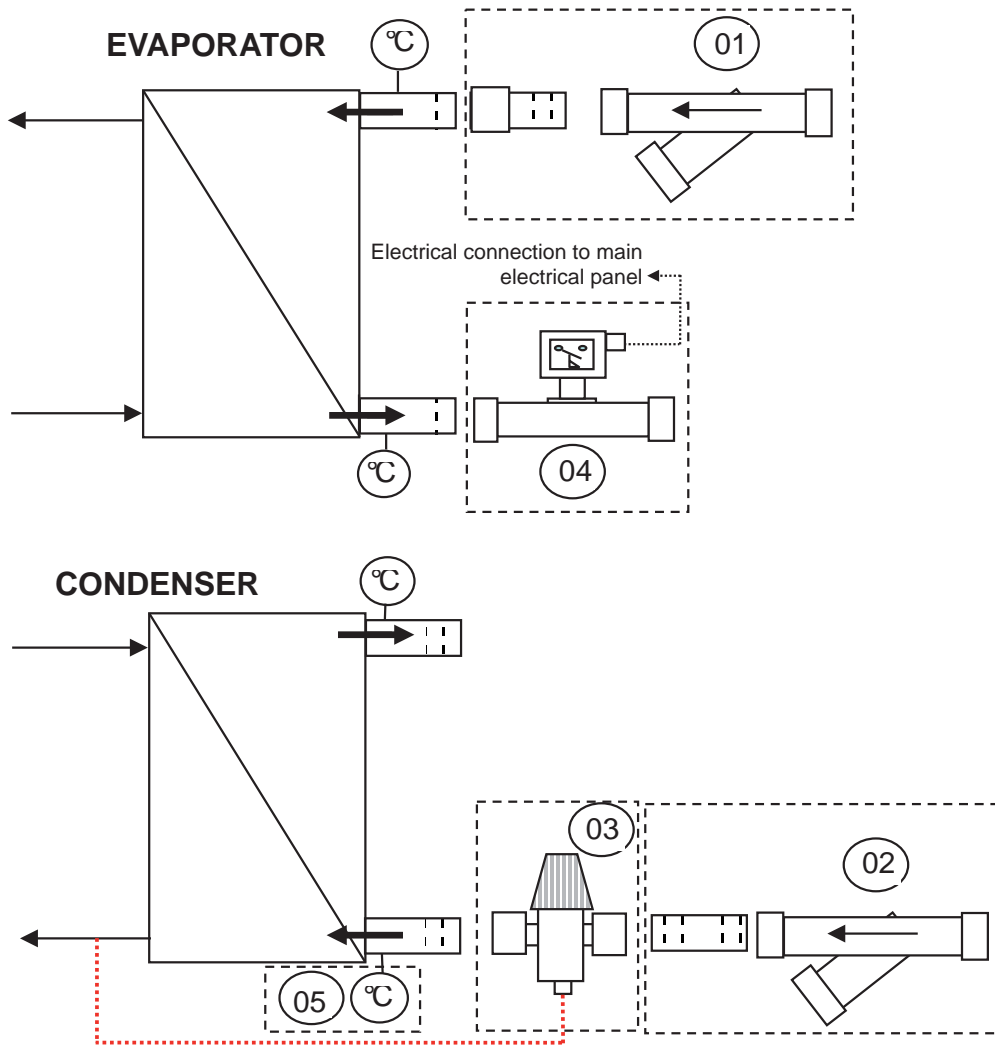

Components supplied «loose" as Option	
01	Evaporator water inlet filter
02	Condenser water inlet filter
03	Pressure regulated water valve
Components supplied «loose" as standard	
04	Paddle flow switch
Components mounted inside the unit, as an option	
05	Outlet water temperature probes for hot water control

025 - 035

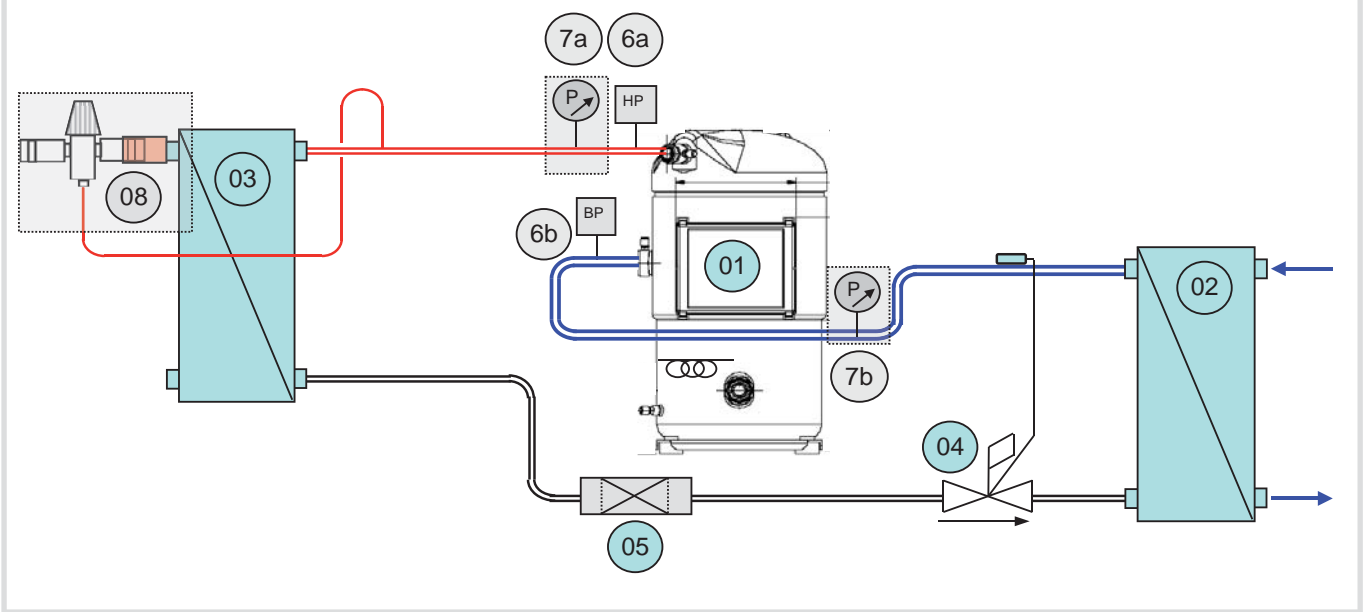

050 - 070 - 080

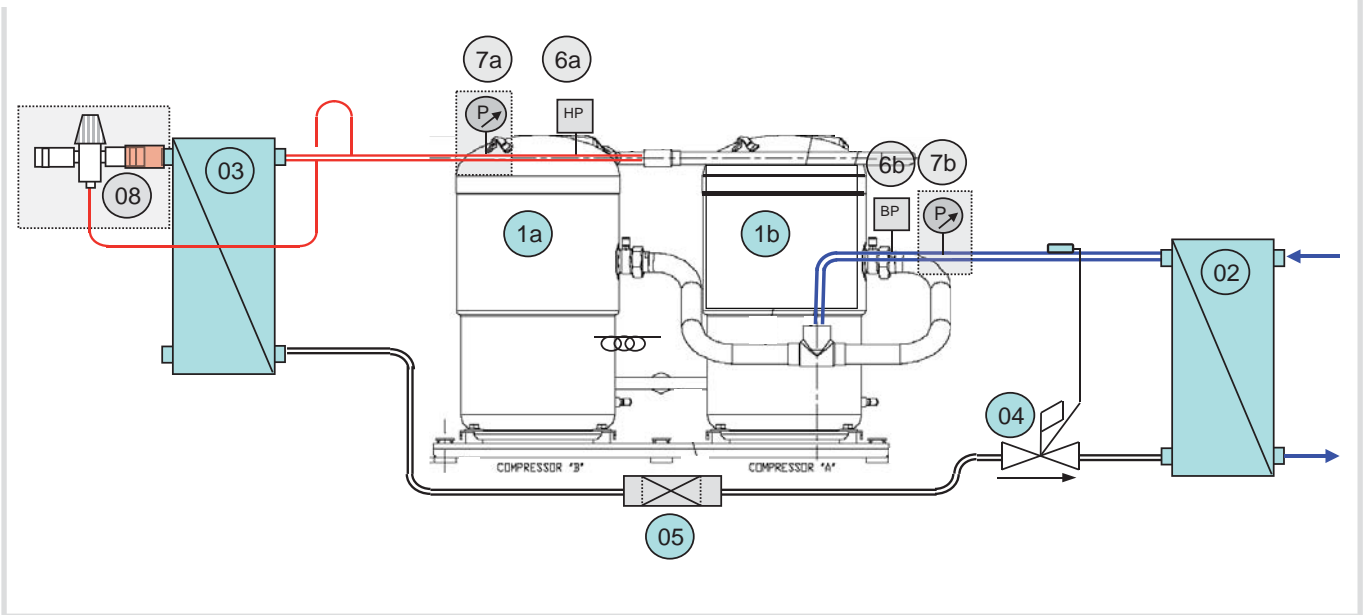

Standard Components	
01.a/ 01.b/ 01.c	Compressors
02	Evaporator
03	Condenser
04	Thermostatic expansion valve
05	Filter drier
06a/ 06b/	Low & high pressure switch

Options	
07a/ 07b/	Low & high pressure gauges
08	Pressure regulated water valve

SWC

Cooling mode

100 - 120 - 135 - 160

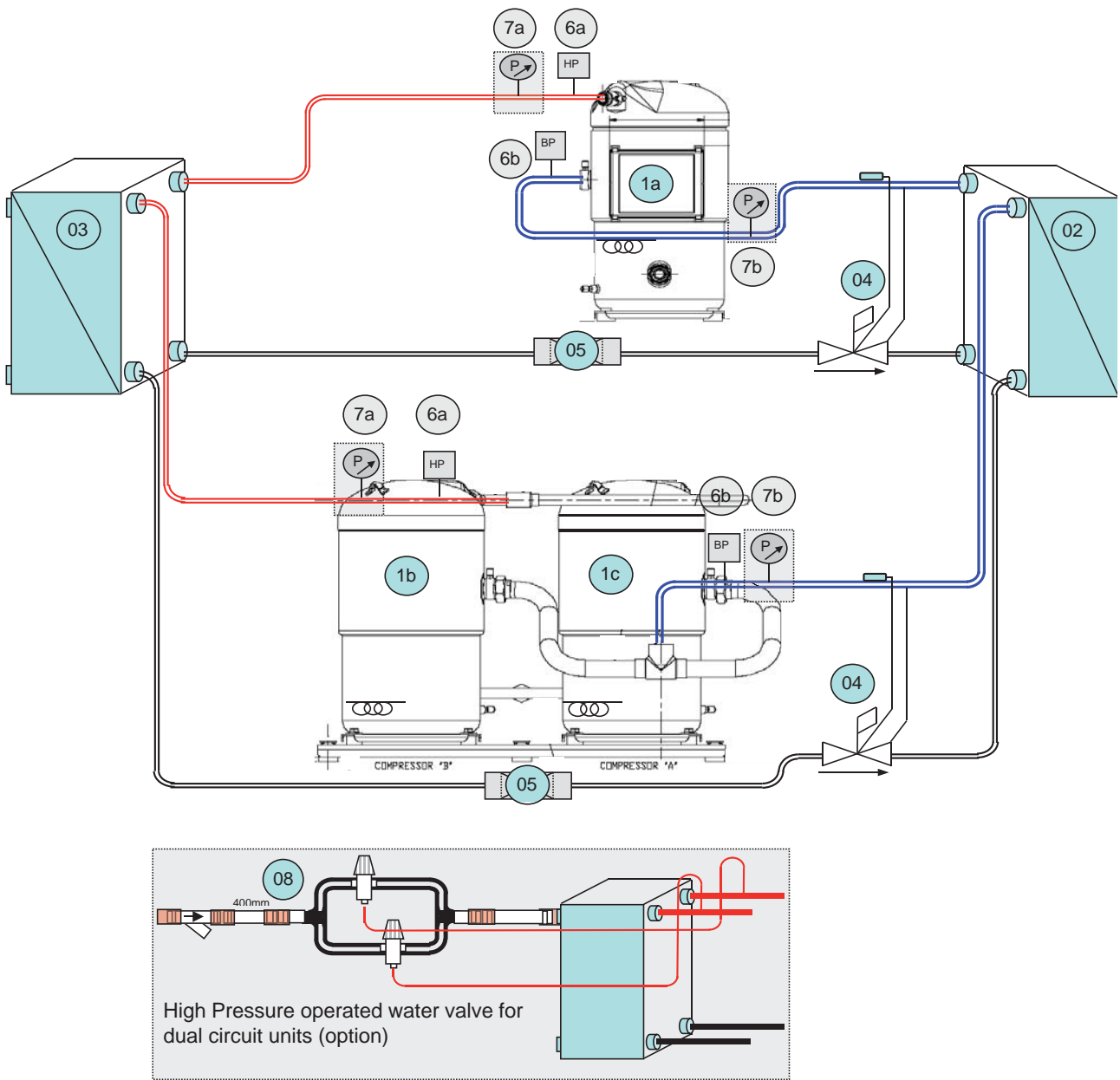

Standard Components	
01.a/ 01.b/ 01.c	Compressors
02	Evaporator
03	Condenser
04	Thermostatic expansion valve
05	Filter drier
06a/ 06b/	Low & high pressure switch

Options	
07a/ 07b/	Low & high pressure gauges
08	Pressure regulated water valve

025 - 035

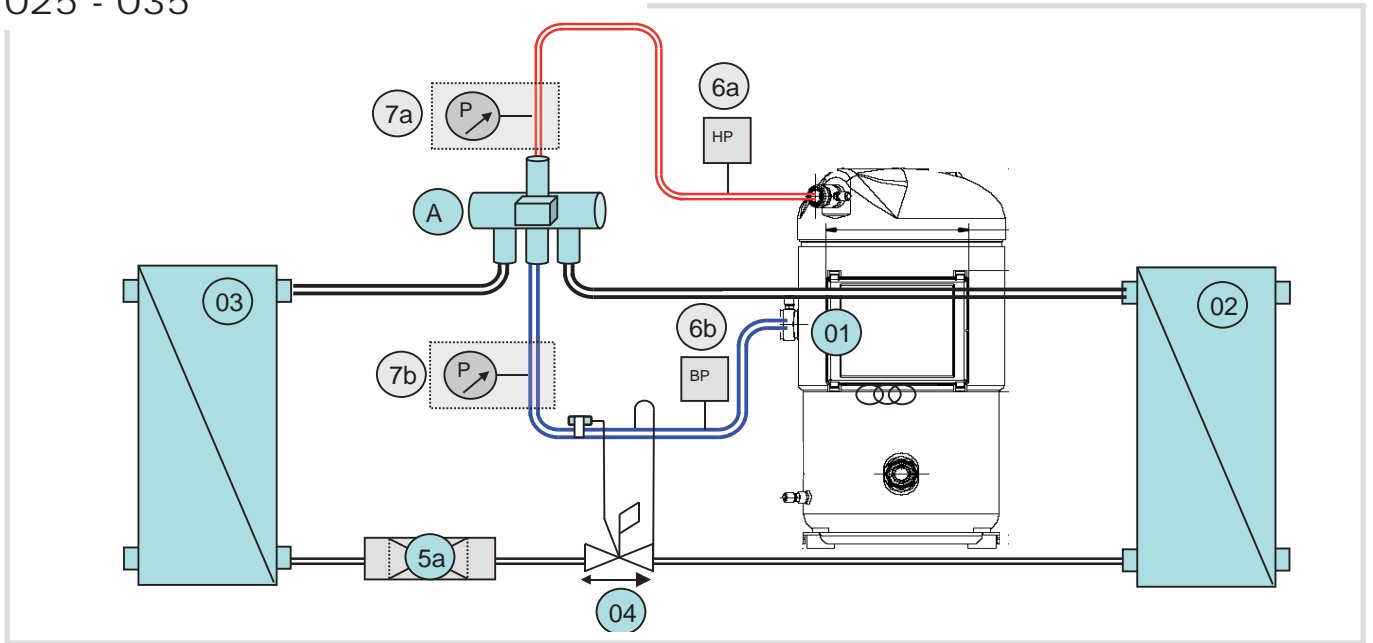

050 - 070 - 080

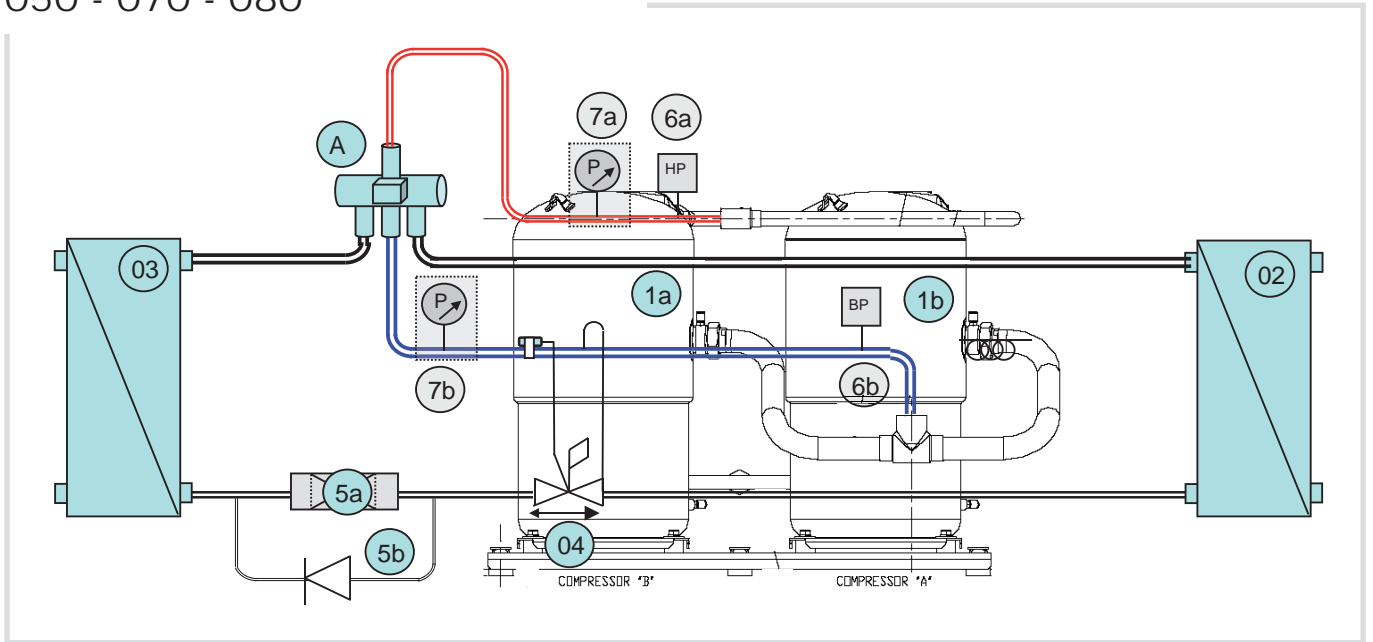

Standard Components	
01.a/ 01.b/	Compressors
02	Evaporator
03	Condenser
04	Thermostatic expansion valve
05	Filter drier & filter by-pass
06.a 06.b	Low & high pressure switch
A	4 way reversing valve

Options	
07.a/ 07.b/	Low & high pressure gauges

100 - 120 - 135 - 160

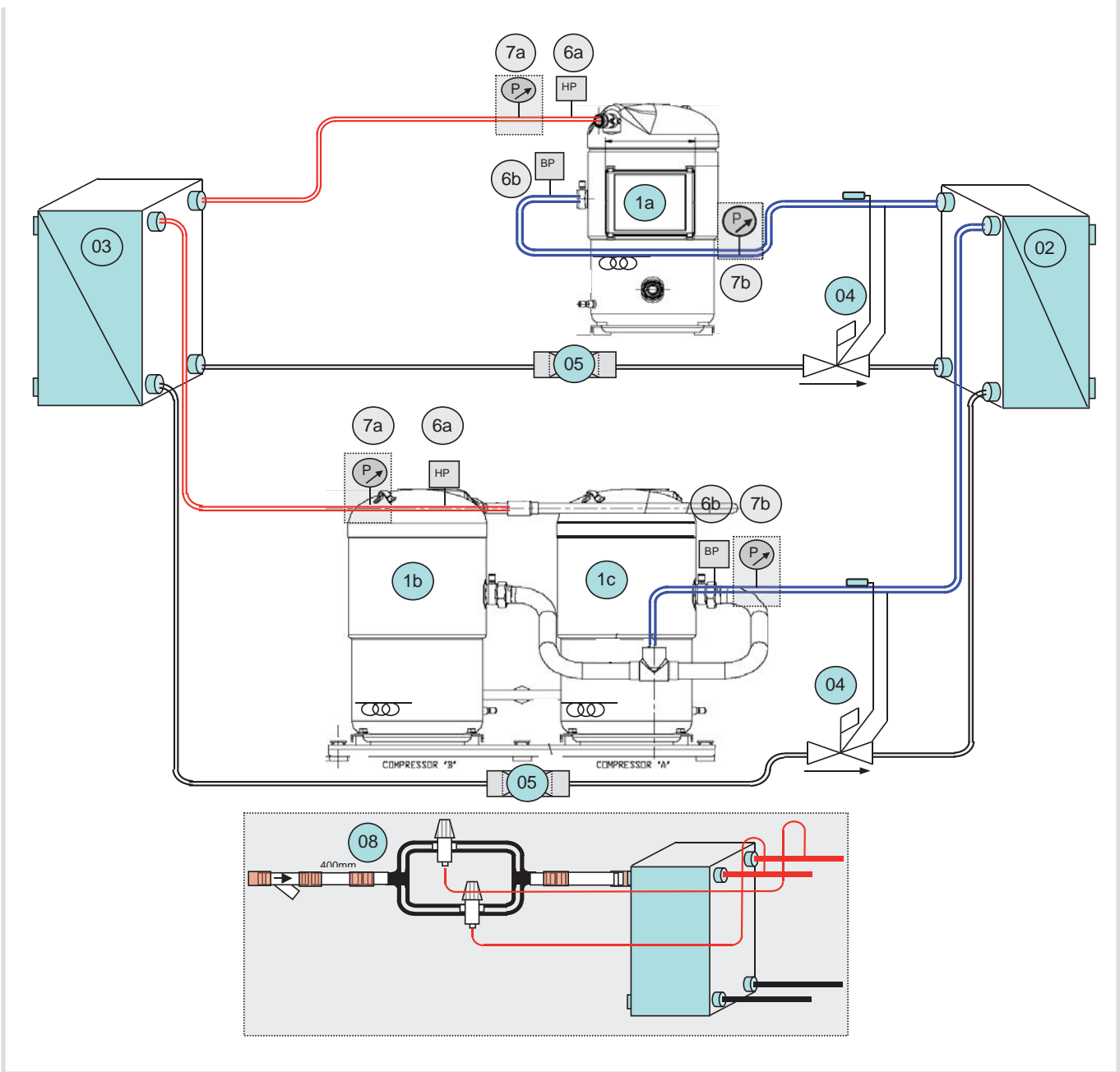

Standard Components	
01.a/ 01.b/	Compressors
02	Evaporator
03	Condenser
04	Thermostatic expansion valve
05	Filter drier & filter by-pass
06.a 06.b	Low & high pressure switch
A	4 way reversing valve

Options	
07.a/ 07.b/	Low & high pressure gauges

025 - 035

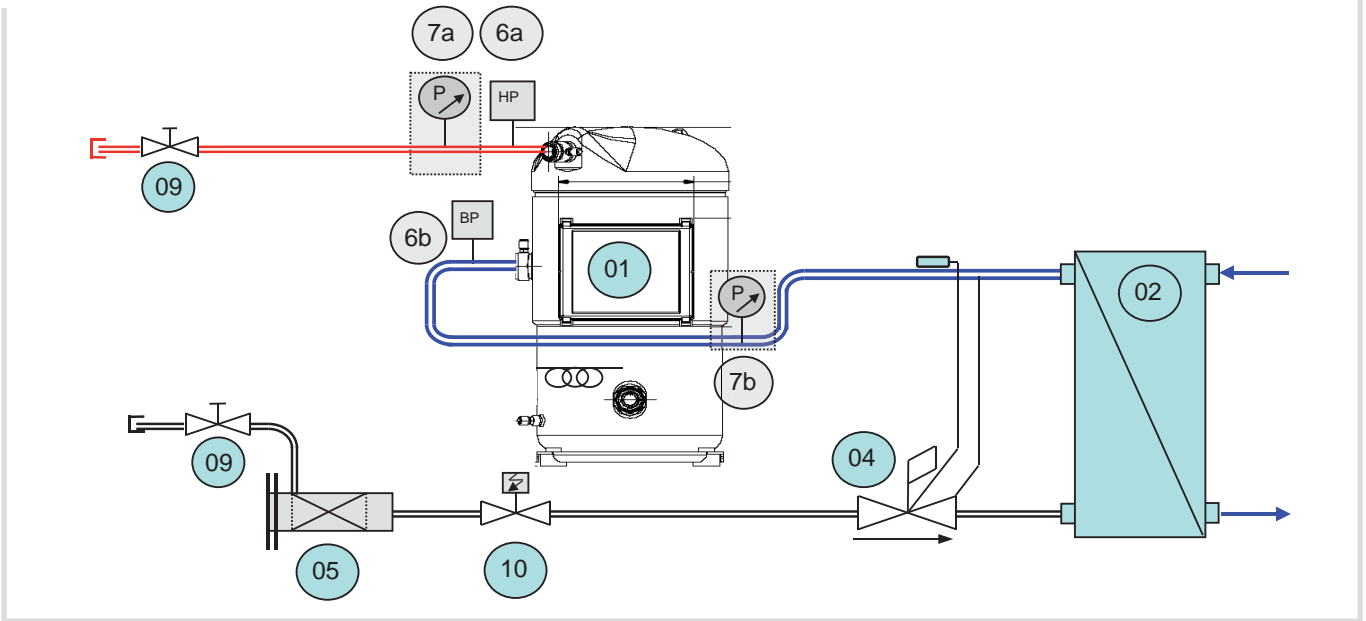

050 - 070 - 080

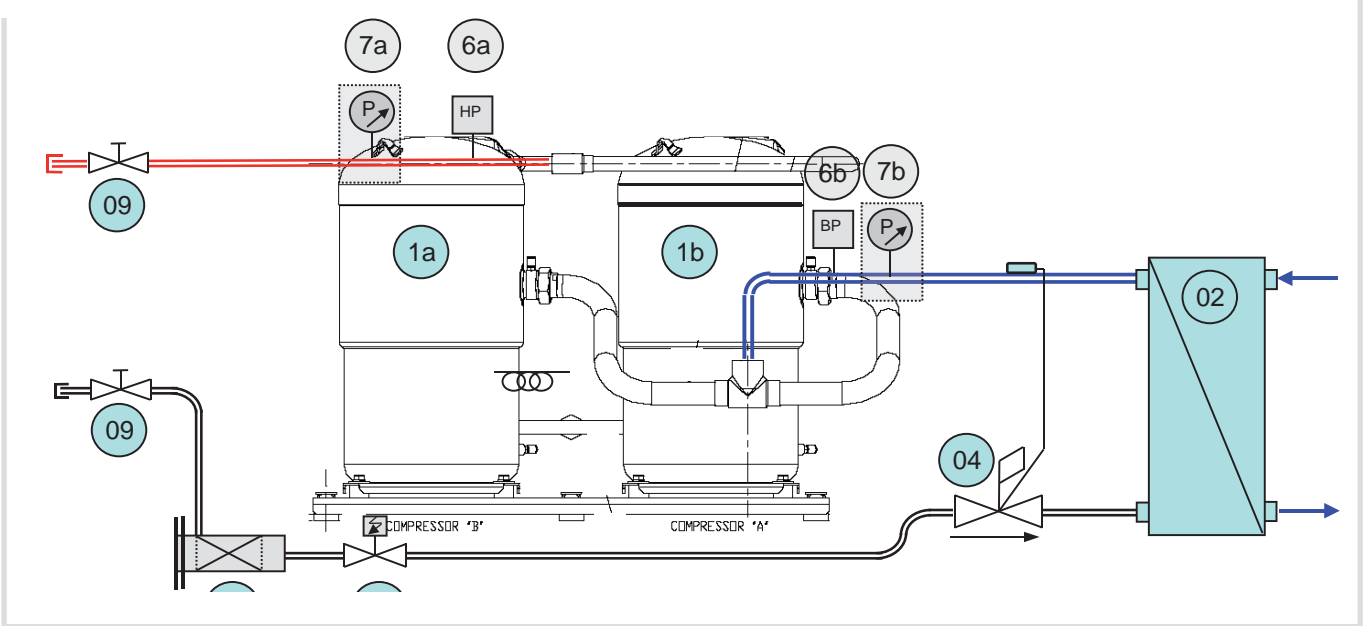

Standard Components

01.a/ 01.b/ 01.c	Compressors
02	Evaporator
03	Condenser
04	Thermostatic expansion valve
05	Removable cartridge drier filter
06.a 06.b	Low & high pressure switch
09	Manual shut off valve

10	Liquid solenoid valve
----	-----------------------

Options

07a/ 07b/	Low & high pressure gauges
--------------	----------------------------

SWR
Unit with remote condenser

100 - 120 - 135 - 160

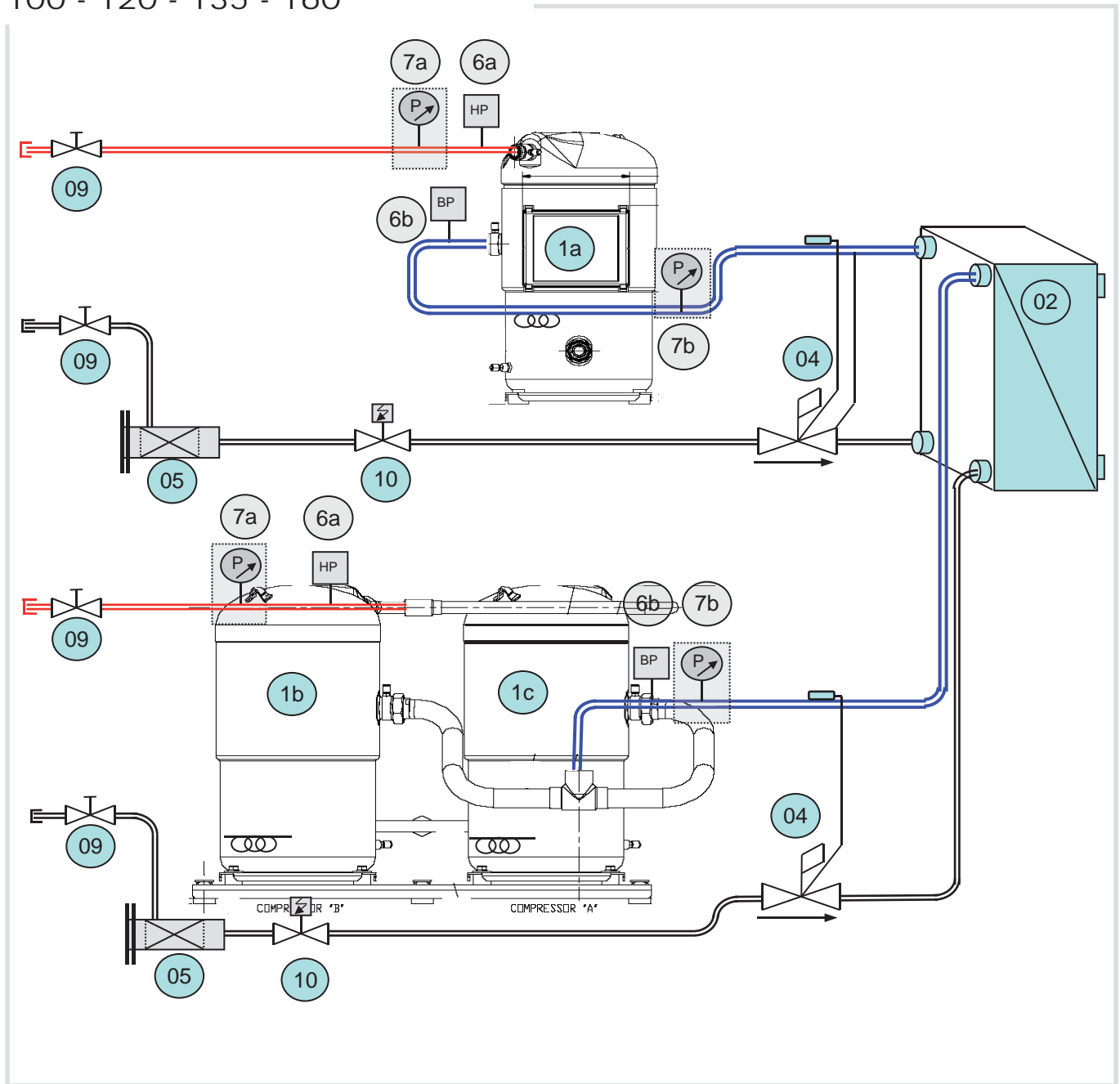

Standard Components	
01.a/ 01.b/ 01.c	Compressors
02	Evaporator
03	Condenser
04	Thermostatic expansion valve
05	Removable cartridge drier filter
06.a 06.b	Low & high pressure switch
09	Manual shut off valve

10	Liquid solenoid valve
----	-----------------------

Options	
07.a/ 07.b/	Low & high pressure gauges

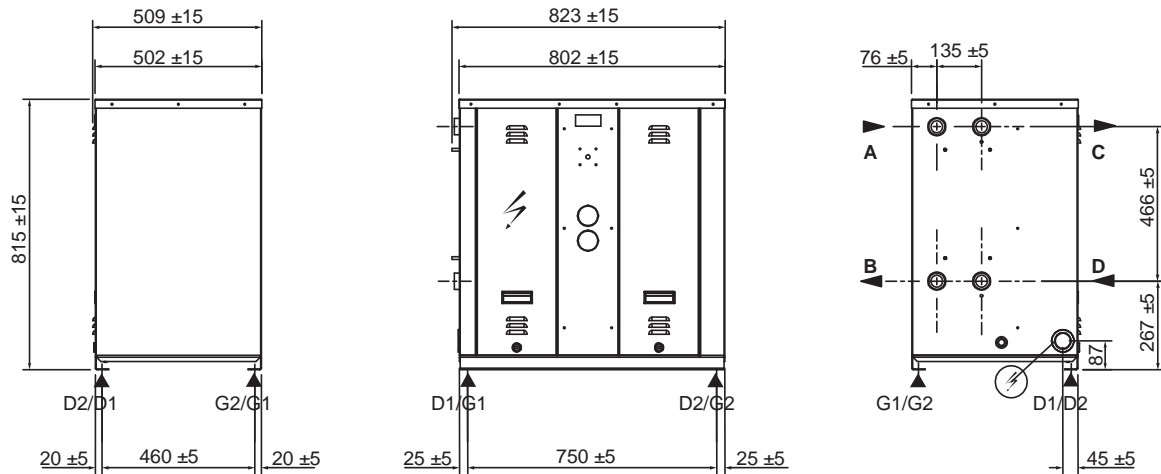
HYDROLEAN 025 / 035
DIMENSIONAL DATA

**LOAD DISTRIBUTION
(kg - Operating weights)**

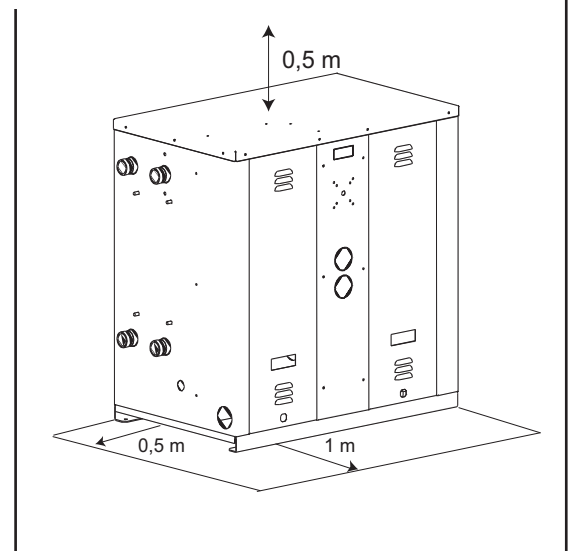
	SWC		SWH		SWR	
	G1	G2	G1	G2	G1	G2
025	44	44	45	45	39	39
035	62	62	63	63	49	49
	D1	D2	D1	D2	D1	D2
	020	44	44	45	45	39
035	62	62	63	63	49	49

CLEARANCES

PIPING

A Box 025/035		SWC	SWH	SWR
EVAPORATOR		<i>All units</i>		
Water inlet	A	1" 1/2 DN40		
Water outlet	B	1" 1/2 DN40		
CONDENSER		SWC		
Water inlet	D	1" 1/2 DN40		-
Water outlet	C	1" 1/2 DN40		-
CONDENSER		SWH	SWR	
Water inlet	C	1" 1/2 DN40		-
Liquid line	D	-	5/8"	
Water outlet	D	1" 1/2 DN40		-
Discharge Line	C	-	7/8"	

**OPTIONAL RUBBER
ANTIVIBRATION MOUNTS**

HYDROLEAN		025	035
Type of rubber mounts		APK80/45Sh A	APK80/60Sh A
Number per unit	#	4	4
Height	(C) mm	27	27
Thread diameter	E mm	M8	M8
Max. thread length	mm	10	11,8

HYDROLEAN 050/070/080

DIMENSIONAL DATA

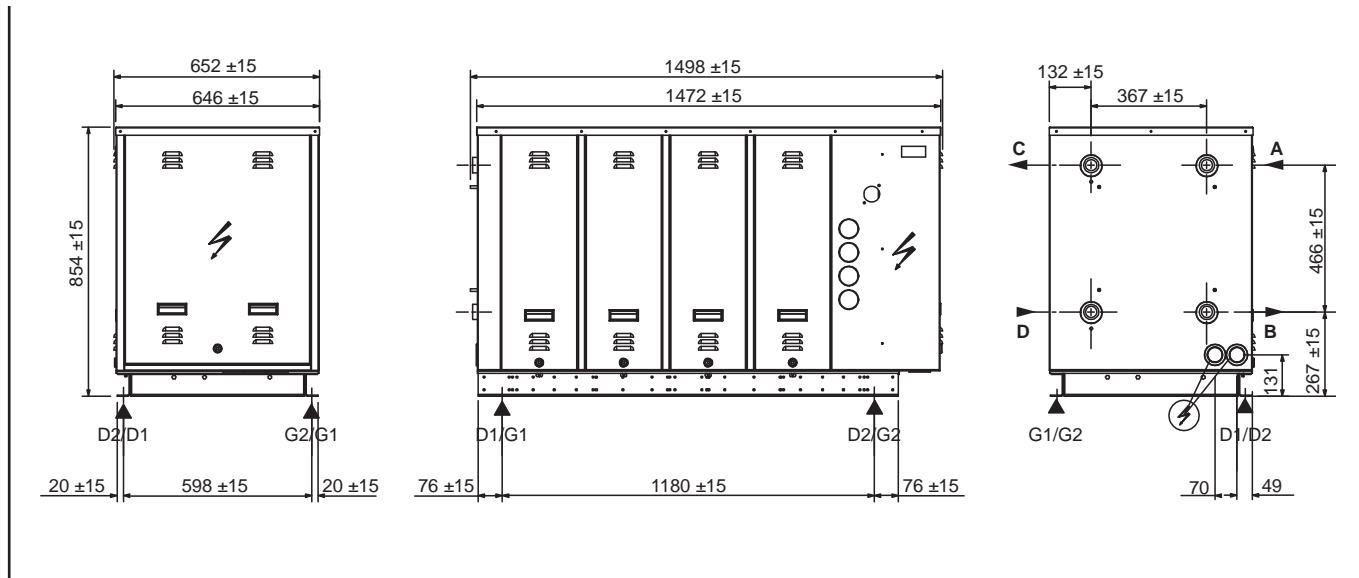

LOAD DISTRIBUTION
(kg - Operating weights)

	SWC		SWH		SWR	
	G1	G2	G1	G2	G1	G2
050	83	83	85	85	73	73
070	95	95	96	96	79	79
080	99	99	101	101	80	80
	D1	D2	D1	D2	D1	D2
	050	83	83	85	85	73
070	95	95	96	96	79	79
080	99	99	101	101	80	80

CLEARANCES

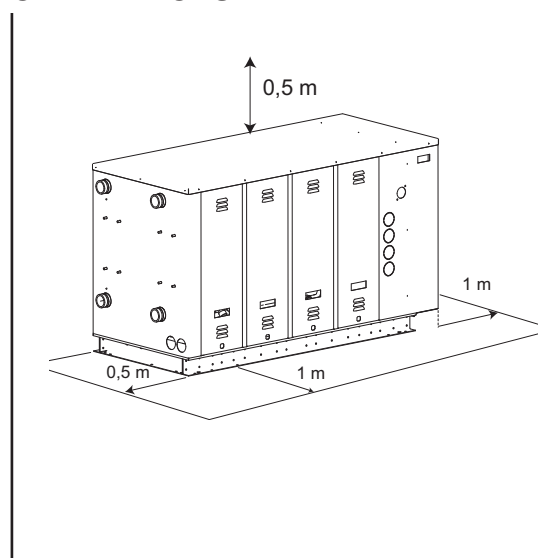

PIPING

B Box 050/070/080		SWC	SWH	SWR	
EVAPORATOR					
Water inlet	A	1" 1/2 DN40			
Water outlet	B	1" 1/2 DN40			
CONDENSER					
		SWC	-		
Water inlet	D	1" 1/2 DN40			
Water outlet	C	1" 1/2 DN40			
CONDENSER					
		SWH	SWR		
Water inlet	C	1" 1/2 DN40			
Liquid line	D	-			
Water outlet	D	1" 1/2 DN40			
Discharge Line	C	-			
		1" 1/8			

OPTIONAL RUBBER ANTIVIBRATION MOUNTS

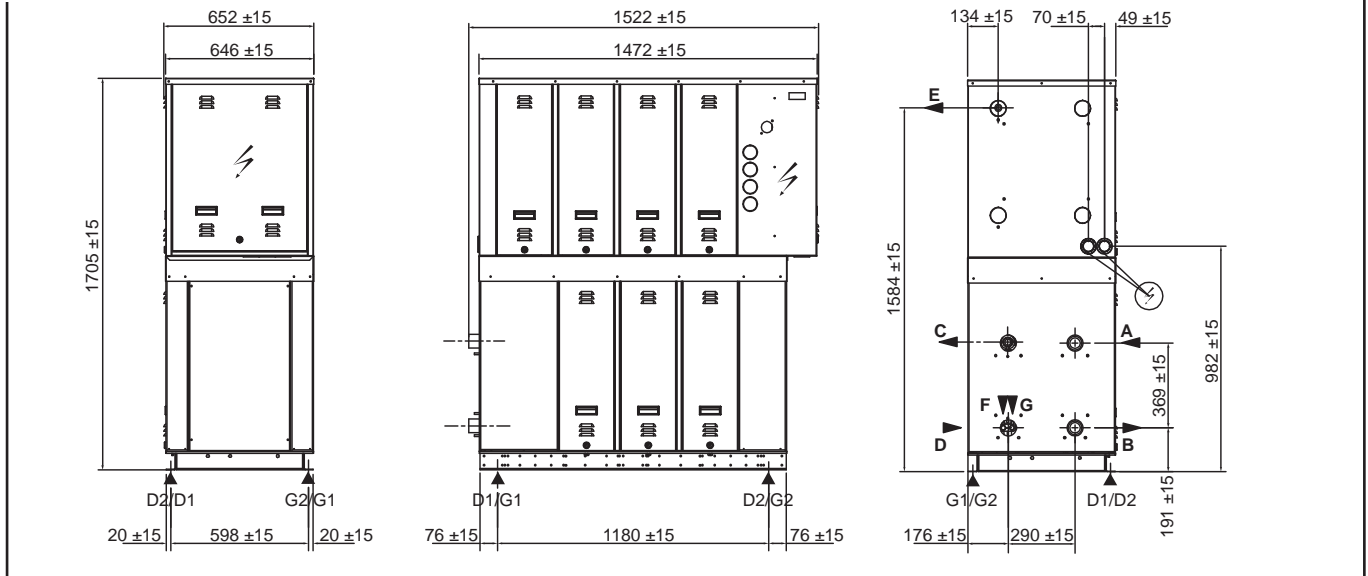

HYDROLEAN	050	070	080
Type of rubber mounts	APK80/75Sh A		APK100/60Sh A
Number per unit	#	4	4
Height	(C) mm	27	28
Thread diameter	E mm	M8	M10
Max. thread length	mm	12,8	10

HYDROLEAN 100/120/135/160
DIMENSIONAL DATA

**LOAD DISTRIBUTION
(kg - Operating weights)**

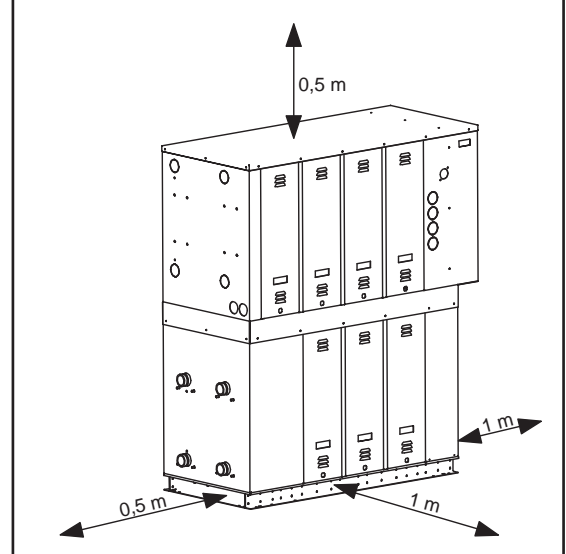
	SWC		SWH		SWR	
	G1	G2	G1	G2	G1	G2
100	152	152	154	154	125	125
120	154	154	156	156	128	128
135	185	185	187	187	150	150
160	190	190	193	193	155	155
	D1	D2	D1	D2	D1	D2
	100	152	152	154	125	125
120	154	154	156	156	128	128
135	185	185	187	187	150	150
160	190	190	193	193	155	155

CLEARANCES

PIPING

C Box 100/120/135/160		SWC	SWH	SWR
EVAPORATOR				
Water inlet	A	2" DN50		
Water outlet	B	2" DN50		
CONDENSER				
		SWC	-	
Water inlet	D	2" DN50	-	
Water outlet	C	2" DN50	-	
CONDENSER				
		SWH	SWR	
Water inlet	C	2" DN50	-	
Liquid line (C1)	G	-	7/8"	
Liquid line (C2)	F	-	7/8"	
Water outlet	D	2" DN50	-	
Discharge Line (C1)	E	-	1" 1/8	
Discharge Line (C2)	C	-	1" 3/8"	

**OPTIONAL RUBBER
ANTIVIBRATION MOUNTS**

HYDROLEAN	100/120/135/160	
Type of rubber mounts	APK100/75Sh A	
Number per unit	#	4
Height	(C) mm	28
Thread diameter	E mm	M10
Max. thread length	mm	10



lennoxemeia.com

SALES OFFICES :

BELGIUM AND LUXEMBOURG

+ 32 3 633 3045

FRANCE

+33 1 64 76 23 23

GERMANY

+49 (0) 40 589 6235 0

ITALY

+ 39 02 495 26 200

NETHERLANDS

+ 31 332 471 800

POLAND

+48 22 58 48 610

PORTUGAL

+351 229 066 050

RUSSIA

+7 495 626 56 53

SPAIN

+34 902 533 920

UKRAINE

+380 44 461 87 79

UNITED KINGDOM AND IRELAND

+44 1604 669 100

OTHER COUNTRIES :

LENNOX DISTRIBUTION

+33 4 72 23 20 00

Due to Lennox's ongoing commitment to quality, the specifications, ratings and dimensions are subject to change without notice and without incurring liability.

Improper installation, adjustment, alteration, service or maintenance can cause property damage or personal injury.

Installation and service must be performed by a qualified installer and servicing agency



HYDROLEAN-AGU-1308-E