

0 5 10 15 20 25 30 35 40 45 50 55 60 65 70 75 80 85 90 95

INDICE	
REGLETERO CONEXIONES ELECTRICAS TERMINAL STRIP BORNIER DE CONNEXION ELECTRIQUE KLEMMLEISTE	HOJA 1/6
CIRCUITO POTENCIA POWER CIRCUIT CIRCUIT DE PUISSANCE STROMKREIS	HOJA 2/6
CIRCUITO MANIOBRA CONTROL CIRCUIT CIRCUIT DE CONTROL STUEERKREIS	HOJA 3/6
CONEXION OPCIONALES OPTIONS CONNEXIONS OPTIONNELS OPTIONEN / ZUBEHÖR	HOJA 4-5/6
LEYENDA REFERENCIAS REFERENCES LEGEND REFERENCE DE LEGENDE LEGENDE	HOJA 6/6



ESQUEMA ELECTRICO
WIRING DIAGRAM
SCHEMA ELECTRIQUE
SCHALTPLAN

Elemento Opcional
Optional Element
Element optionnel
Optionales bauteil

A realizar por el instalador
To wire by the installer
A câbler par l'installateur
Verdrahtung durch den installateur

%	Lennox Refrac S.A.	ESQUEMA ELECTRICO ELECTRIC DIAGRAM	EAC 1003 1103 SM3	4Z-33-630-611 14K 3N ~ 400V 50Hz + PE
----------	--------------------	---------------------------------------	--------------------------	--

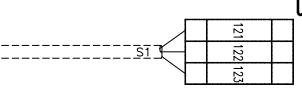

0 5 10 15 20 25 30 35 40 45 50 55 60 65 70 75 80 85 90 95

⚠ RETIRAR PUNTE SI SE MONTA ON/OFF REMOTO
 REMOVE LINK FOR REMOTE ON/OFF OPERATION
 RETIRER LE PONT EN CAS DE MARCHÉ/ARRÊT A DISTANCE
 ENFERNE DIE VERBINDUNG ZUM EIN/AUS FERNSCHALTER

⚠ ESTAS BORNAS SOLAMENTE SE INCLUYEN CON SU OPCIONAL
 THESE TERMINALS ARE ONLY INCLUDED WITH ITS OPTIONAL
 CES CONTACTS SONT INSTALLES SEULEMENT SI ON DEMANDE CHOISIT L'OPTIONAL
 DIESE ANSCHLUSSKLEMMEN SIND NUR MIT ZUBEHÖR VERFÜGBAR IHREM OPTIONAL

VER MANUAL INSTALACION
 SEE INSTALLATION MANUAL (IOM)
 VOIR LE MANUEL D'INSTALLATION
 SIEHE INSTALLATIONSHANDBUCH (IOM)

INTERRUPTOR GENERAL
 MAIN SWITCH
 INTERRUPTEUR GENERAL
 HAUPTSCHALTER

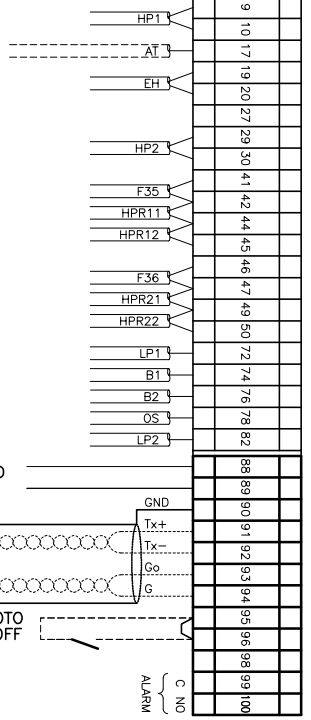
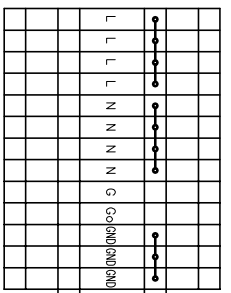
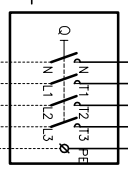

INT. DE FLUJO
 WATER FLOW

⚠ ON/OFF REMOTO
 REMOTE ON/OFF

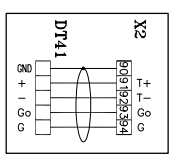

Cable section	2x Twisted pair AWG 20
100m max	
Cable section	1x Twisted pair AWG 20
+ 2x 1.5mm ²	
200m max	

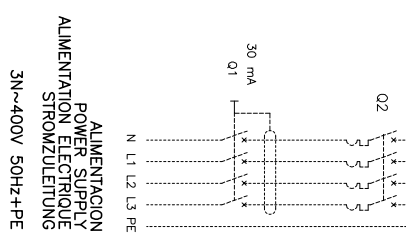
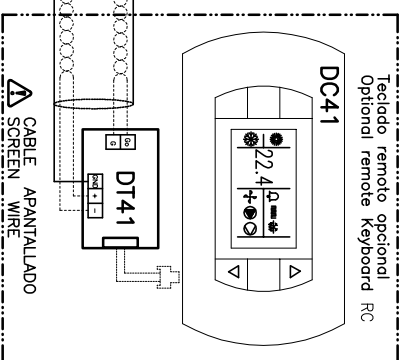

Elemento Opcional
 Optional Element
 Element optionnel
 Optionales bauteil

A realizar por el instalador
 To wire by the installer
 A câbler par l'installateur
 Verdrahtung durch den installateur

1/6
 Lemnox Refoc S.A.

ESQUEMA ELECTRICO
 ELECTRIC DIAGRAM

EAC 1003 1103 SM3

42-33-630-611 14K
 3N ~ 400V 50Hz + PE
 3N~400V 50Hz+PE

ALIMENTACION
 POWER SUPPLY
 ELECTRIQUE
 STROMZULEITUNG

0 5 10 15 20 25 30 35 40 45 50 55 60 65 70 75 80 85 90 95

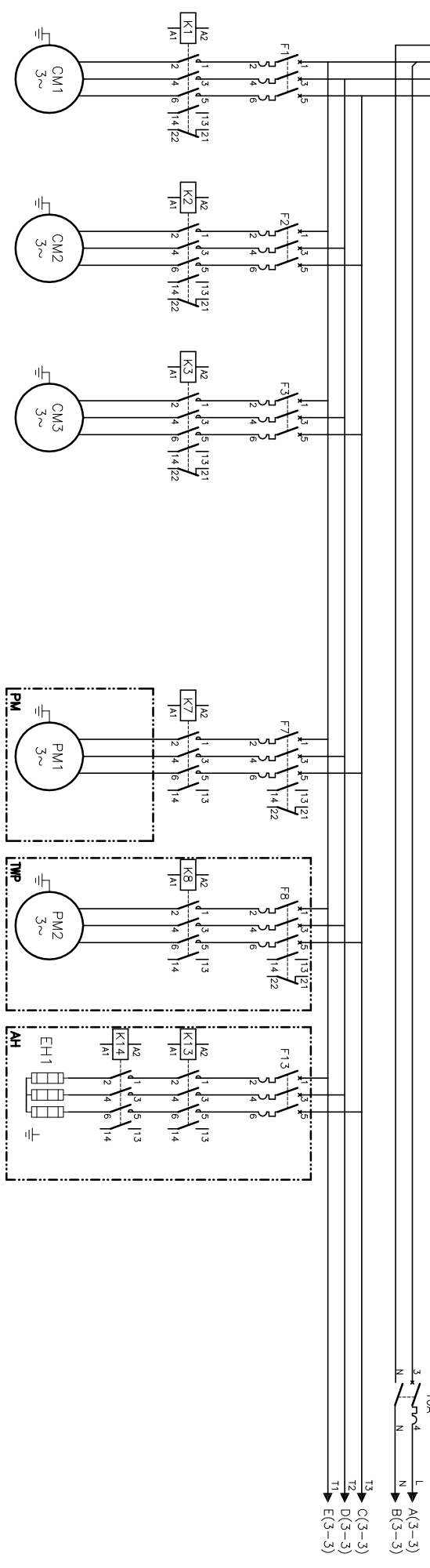
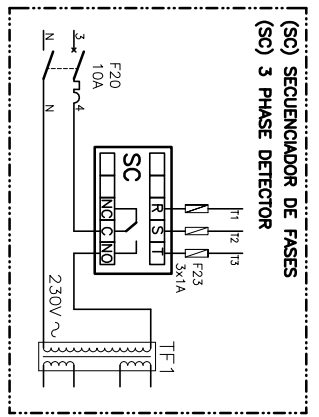
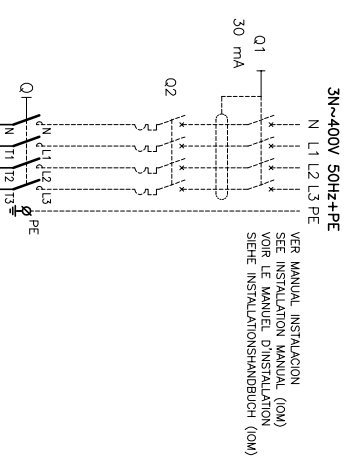

EAC	Im(CC)	22A	31A	4,95A	4,95A	8,7A
1003	Iq(LRA)	118A	198A	25A	25A	
SM3	F	32A	32A	4,63A	4,63A	10A
EAC	Im(CC)	25,6A	31A	4,95A	4,95A	8,7A
1103	Iq(LRA)	158A	198A	25A	25A	
SM3	F	32A	32A	4,63A	4,63A	10A

Elemento Opcional
Optional Element
Element optionnel
Optionales bauteil

A realizar por el instalador
To wire by the installer
A câbler par l'installateur
Verdrahtung durch den Installateur

2/6
Lemnox Refrac S.A.
ESQUEMA ELECTRICO
ELECTRIC DIAGRAM

EAC 1003 1103 SM3

4Z-33-630-611 14K
3N ~ 400V 50Hz + PE

0 5 10 15 20 25 30 35 40 45 50 55 60 65 70 75 80 85 90 95

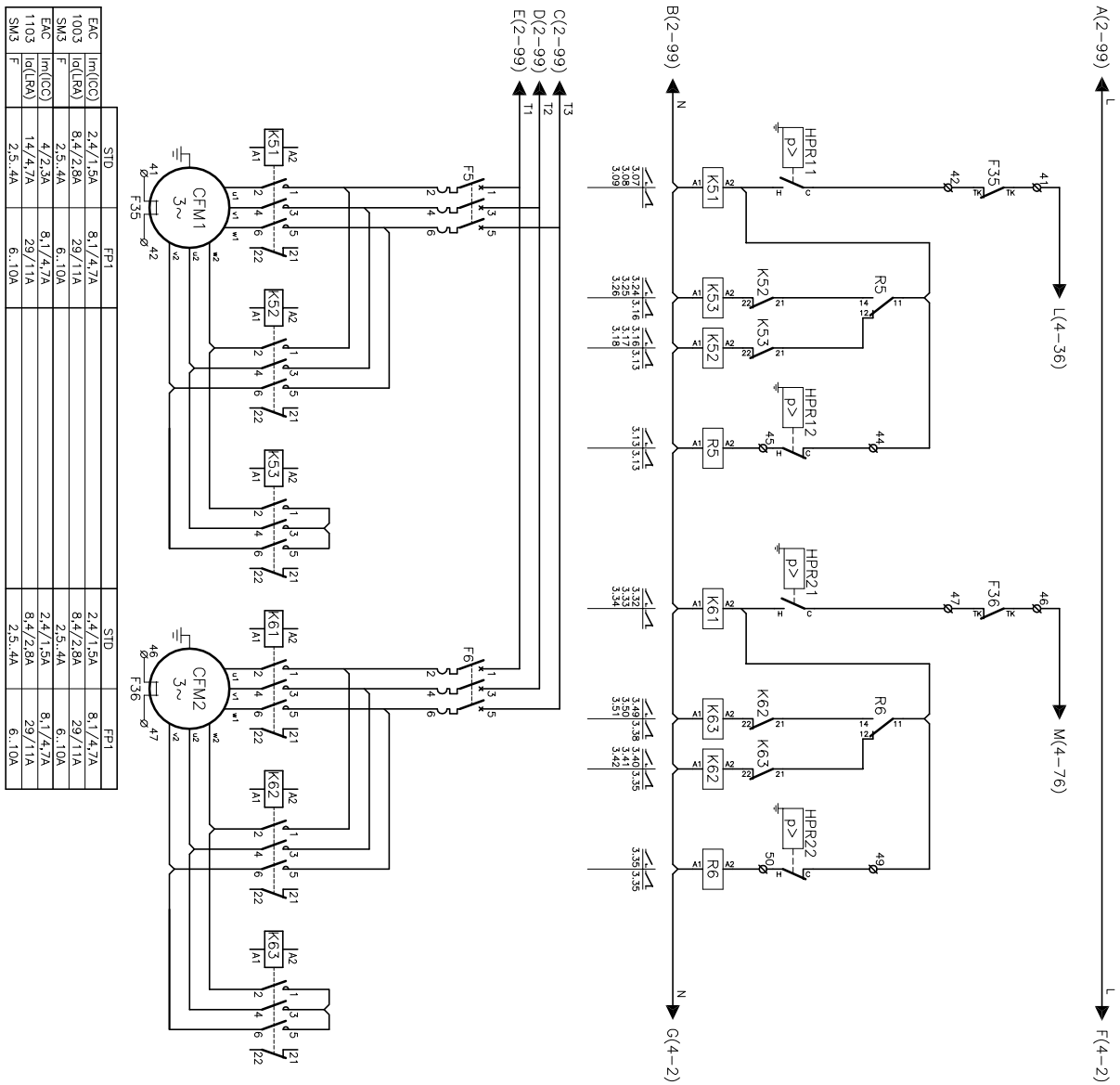

	STD	FP1	STD	FP1	
EAC	Im(GC)	2.4/1.5A	8.1/4.7A	2.4/1.5A	8.1/4.7A
1003	Im(LBA)	8.4/2.8A	29/11A	8.4/2.8A	29/11A
SMS	F	2.5-4A	6.10A	2.5-4A	6.10A
EAC	Im(GC)	4/2.3A	8.1/4.7A	2.4/1.5A	8.1/4.7A
1103	Im(LBA)	14/4.7A	29/11A	8.4/2.8A	29/11A
SMS	F	2.5-4A	6.10A	2.5-4A	6.10A

Elemento Opcional
 Optional Element
 Element optionnel
 Opcionales bauteil

A realitzar per el instalador
 To wire by the installer
 A câbler par l'installateur
 Verdrahtung durch den installateur

3/6	Lemnox Refrac S.A.	ESQUEMA ELECTRICO ELECTRIC DIAGRAM	EAC 1003 1103 SMS	42-33-630-611 14K 3N ~ 400V 50Hz + PE
------------	--------------------	---------------------------------------	--------------------------	--

0 5 10 15 20 25 30 35 40 45 50 55 60 65 70 75 80 85 90 95

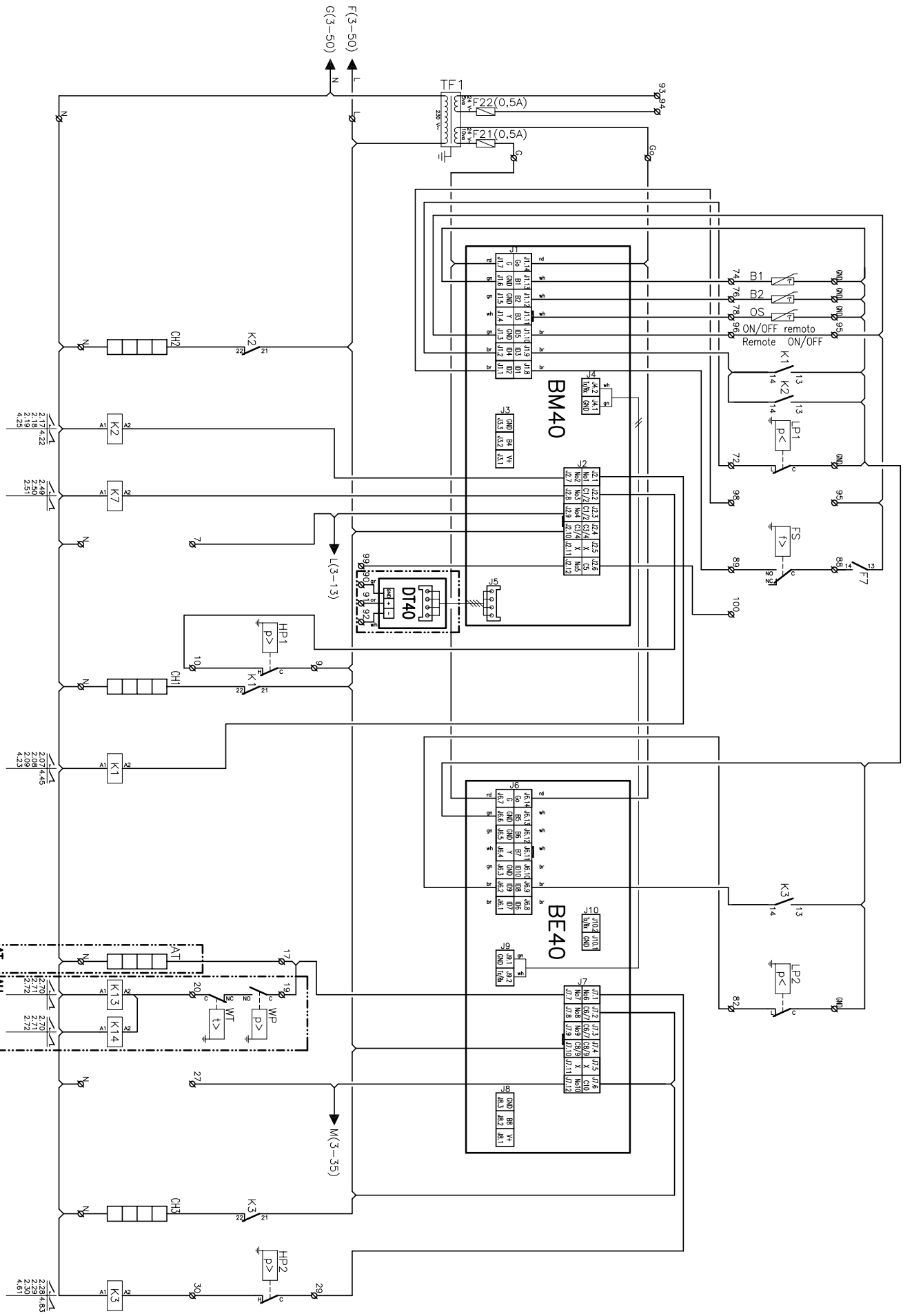

Elemento Opcional
 Optional Element
 Element optionnel
 Optionales bauteil

A realitzar per el instalador
 To wire by the installer
 A câbler par l'installateur
 Verdrahtung durch den installateur

4/6
 Lemnox Refrac S.A.

ESQUEMA ELECTRICO
 ELECTRIC DIAGRAM

EAC 1003 1103 SM3

4Z-33-630-611 14K
 3N ~ 400V 50Hz + PE

(SFS) ARRANCADOR SUAVE / SOFT STARTED

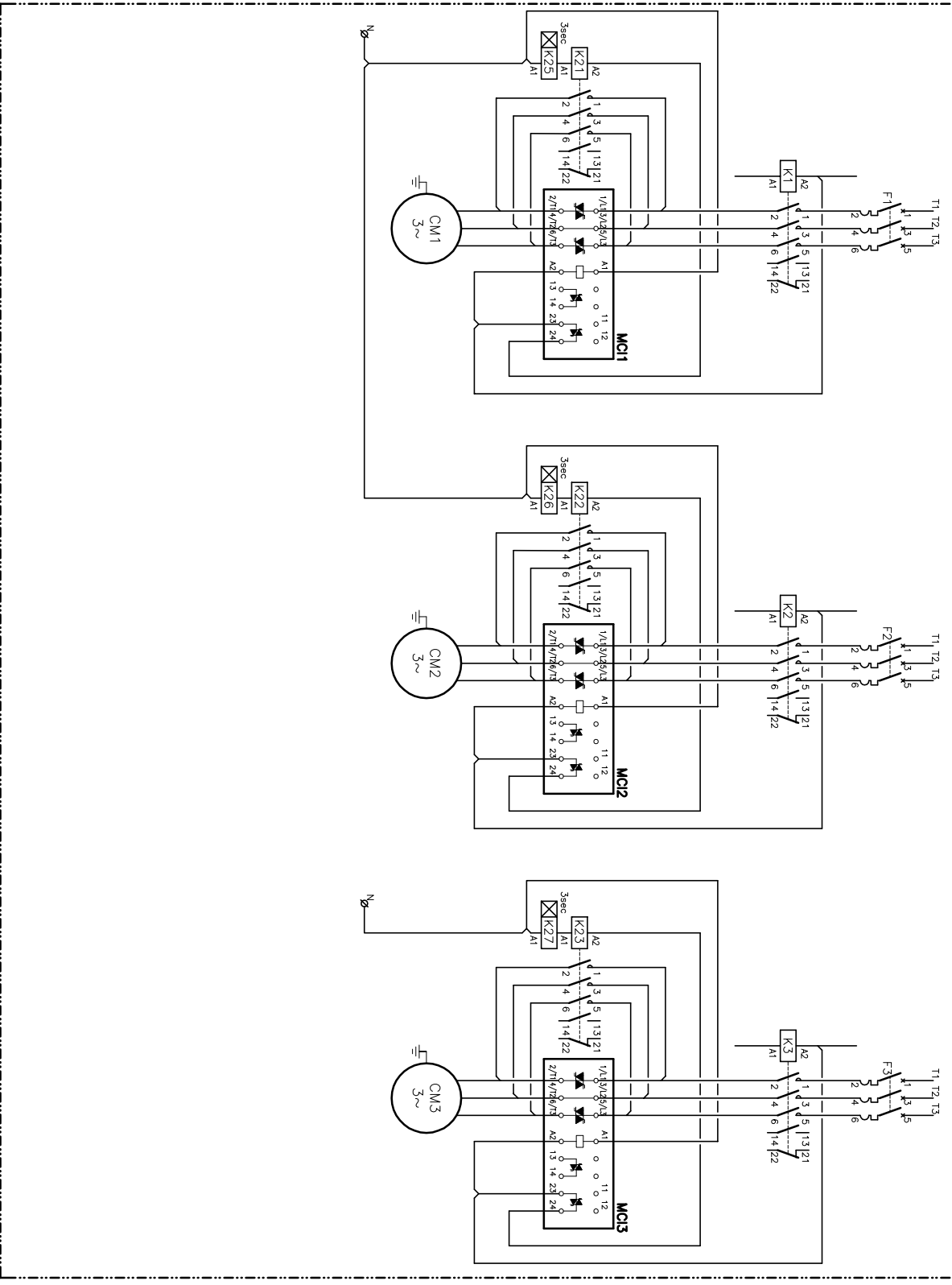

(TWP) BOMBA AGUA DOBLE / TWIN WATER PUMP

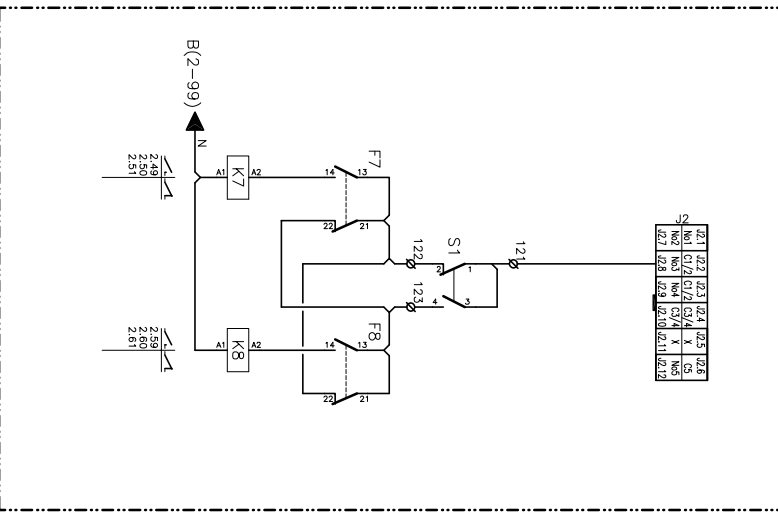

Elemento Opcional
 Optional Element
 Element optionnel
 Optionales bauteil

A realizar por el instalador
 To wire by the installer
 A câbler par l'installateur
 Verdrahtung durch den installateur

5/6

Lemnox Refrac S.A.

ESQUEMA ELECTRICO
 ELECTRIC DIAGRAM

EAC 1003 1103 SM3

4Z-33-630-611 14K
 3N ~ 400V 50Hz + PE

